

LV
VOL#
49A

49A

- 5. DB-4206 TYPE OD TRIP DEVICE REPLACEMENT
PROCEDRES FOR K-1600**
- 6. GEI-50216B GE OVER CIRCUIT TRIP DEVICE TYPE EC-2
FOR TYPES AK-1-15, AK-1-25 AND AK-1-50**
- 7. GEI-90892 FIELD TESTING OF GE TYPE
OVERCURRENT TRIP DEVICES**
- 8. GEK-309B TEST INSTRUCTIONS FOR INSTALLATION
OR SERVICE OF POWER SENSOR TRIP DEVICE USED
ON TYPE AK ACB'S**
- 9. GEH-5369A NUCRI VERSA TRIP RMS-9 PROGRAMMER**
- 10. GEH-5371B MICRO VERSA TRIP RMS-9 AND EPIC
MICRO VERSA TRIP RATING PLUG**
- 11. GEI-86133 GE GROUND FAUL DEFEAT CABLE-TGFD**
- 12. GEK-64466 FE MICRO VERSA TRIP GROUND FAULT
MODULES**
- 13. GEI-48907 GE GROUND FAULT**
- 14. JOSLYN OPTI TRIP 1 RMS**
- 15. JOSLYN OPTI TRIP 2 RMS**
- 16. JOSLYN OPTI TRIP 2 RMS**



TYPE OD OVERCURRENT TRIP DEVICE REPLACEMENT PROCEDURE FOR K-1600 CIRCUIT BREAKERS

General

The overcurrent trip device as shown in Figure 1 has been designed to provide a means of automatically opening the circuit breaker under abnormal current conditions. General instructions for the overcurrent trip device for the K-1600 circuit breakers are given in instructions IB-5720 and IB-5721. Replacement of the K-line overcurrent trip device can be readily accomplished in the field.

Removal Procedure

Instructions for the replacement of the overcurrent trip devices are given as follows:

DE-ENERGIZE THE PRIMARY AND CONTROL CIRCUITS BEFORE PROCEEDING WITH ANY WORK.

This is automatically done in racking out a drawout type unit. However, with the stationary type greater care must be exercised in removing the electrical connections. All external electrical connections which are to be removed should be identified properly before disconnecting. Recommended procedure for working on any K-line circuit breaker is to remove the breaker from its enclosure and place it on a convenient work bench.

- (a) The mounting support (1) in Figure 2 for the secondary control contacts (2) on the drawout type circuit breaker must be detached from the panel by removing the four mounting screws (4). The primary disconnect contacts (3) should also be removed from the terminal stud (6) by removing their retaining pins.

As there are no secondary or primary contacts on the stationary type breakers, it will not be necessary to remove these items as described above.

- (b) The overcurrent trip devices are to be separated from the circuit breaker panel by removing the four terminal screws (7) located above the circuit breaker terminal studs (6).

NOTE: These screws (7) as well as the four screws (8) have been fastened by power-driven tools at the factory and it will be necessary to exert a relatively great effort to remove them.

- (c) The four mounting screws (8) should then be removed from the lower molding (5). The complete overcurrent trip device assembly can then be taken from the rear of the circuit breaker support panel.

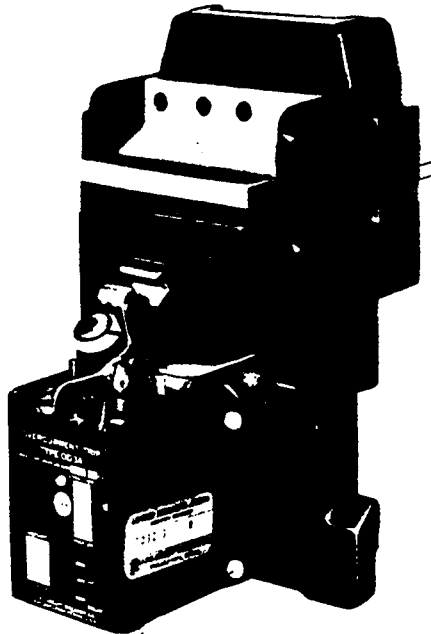

Photo 30042-R

Fig. 1. Lower molding assembly with standard type OD overcurrent trip devices for K-Line circuit breakers.

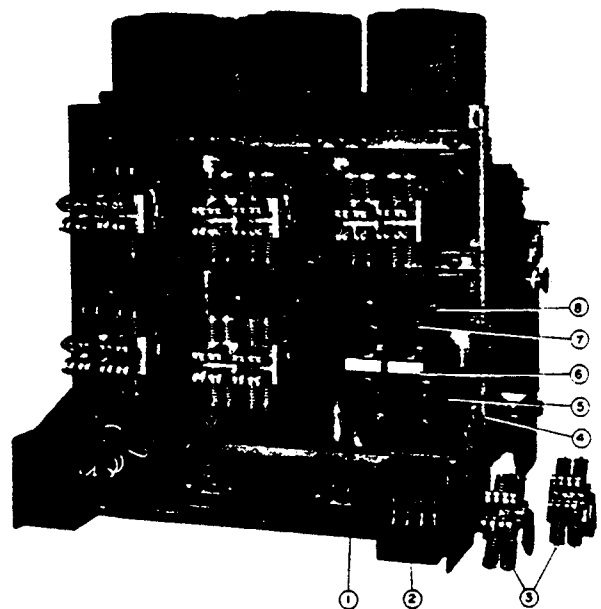

Photo 30263-A

Fig. 2. Rear view of K-1600 Drawout Circuit Breaker.



Replacement Procedure

- (a) The replacement overcurrent trip assembly is factory-calibrated before shipment. Inspect the unit carefully for correctness of proper current rating and settings before mounting. Carefully insert the overcurrent trip unit in place. Fasten to circuit breaker panel by means of mounting screws (8). Terminal mounting screws (7) should then be tightened securely. If drawout type the primary and secondary separable contacts should then be replaced.
- (b) Check the armature trip travel by the following steps:
1. Back-out the trip travel adjusting screw (2) in Figure 3 until there is an air gap between the screw (2) and tripper bar (3).
 2. Close the circuit breaker.
 3. Manually hold the tripping armatures in the sealed position against the magnet pole face. (The long-time armature may be difficult to move. Place the breaker on its back and push against the armature with a screwdriver until released by the dashpot.)
 4. Slowly turn-in the adjusting screw (2) until the circuit breaker trips then turn the adjusting screw in one additional full turn.
 5. After making adjustments, recheck the trip travel by slowly pushing up either armature several times. The circuit breaker should then be returned to its enclosure and restored to service.

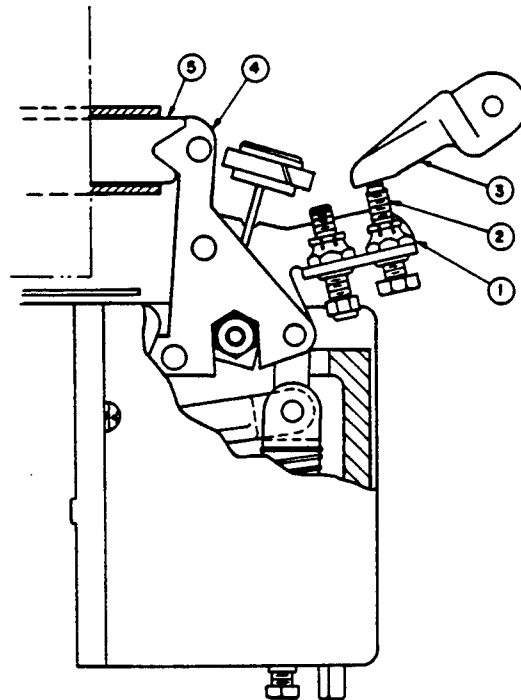

1. Friction Nut
2. Adjusting Screw (Trip Travel)
3. Tripper Bar (Circuit Breaker)
4. Armature
5. Magnet

Dwg. S-14776—Rev. 0

Fig. 3. Type OD overcurrent trip device for K-Line circuit breakers. (Short-time armature shown).



OVERCURRENT TRIP DEVICES FOR K-LINE CIRCUIT BREAKERS

DESCRIPTION

Overcurrent trip devices are used on circuit breakers as a means of automatically opening the circuit breaker under abnormal current conditions. This serves to protect connected electrical equipment from thermal damage due to excessive current flowing for excessive periods of time. Such a device is shown in Fig. 1.

The basic overcurrent trip device used on the K-Line circuit breakers consists of a series operating coil, a magnetic structure and means of introducing time delay restraint to the tripping armatures. The time delay may be in the form of a sealed fluid displacement dashpot or a mechanical escapement disc. Means are provided for adjustment of these various elements to give the required operating characteristics to the overcurrent trip device.

The overcurrent trip device is mounted on a sturdy insulating base molding which in turn is supported on the metal frame of the circuit breaker. This base molding is designed to afford easy removal of the trip device from the rear of the circuit breaker.

The series operating coil must include a sufficient number of turns so that the product of the current flowing in the coil and the number of turns fall within the operating magnetic requirements of the device. The series operating coil may consist of one or more turns of copper. The cross-section of each turn must be sufficiently large so as to carry the rated current of the given coil continuously without exceeding a temperature rise which would damage adjacent insulation.

The operating magnet consists of a clapper-type design with a stationary magnet structure acting on one or two movable pivoted armatures. The series coil turns are interlinked with the magnetic circuit so as to establish a magnetic flux in the magnet iron when current flows in the coil. The operating face of the armature is so shaped as to provide a magnetic force over a relatively long operating stroke.

The trip device may include either one or two armatures pivoting on a common pin. One of these armatures may be such that its pole-face area is of sufficient size as to provide adequate magnetic force to give operation at the minimum currents for which the device is rated. This broad armature we will identify as armature No. 1. The other armature construction identified as No. 2 has a narrower pole area for operation on currents far above the minimum rating of the coil. The use of either or both of these armatures will be determined by the required operating characteristics.

The fluid-displacement time delay dashpot is used to give time delay measurable in seconds, minutes and hours and consist of a wafer-type piston moving within a sealed cylinder containing a silicone fluid. The piston is linked

by a series of levers to the No. 1 armature. A tripping motion of this armature will move the piston downward within the cylinder. This motion is retarded by the pressure of the delay fluid beneath the piston. With a given force from the armature upon the piston, the speed of the piston motion is dependent upon how rapidly the fluid can be displaced up past the piston perimeter. This retards the armature in its tripping stroke. The fluted sections in the cylinder wall are provided to allow acceleration of the piston after an adjustable length of retarded stroke.

These flutes then allow free displacement of the fluid to the top of the piston, thereby reducing the retardation on the piston. A flapper-type relief valve is mounted on the bottom of the piston in such a manner that it closes over a relief orifice on the downward stroke of the piston and opens on the upward stroke. This allows a retardation effect on the armature in a tripping direction but a free motion in a reset direction of the armature.

Silicone fluid is used because of its low change in viscosity with change of fluid temperature. Therefore the time delay of a device using silicone is less subject to temperature change.

The mechanical escapement provides time delay as measurable in milliseconds and is used to delay tripping on the circuit breaker on high fault current flow. It is connected to the armature which we have identified as No. 2. The time delay of this device is obtained due to the retardation of an oscillating verge acting to control the speed of rotation of an escapement wheel. This wheel is operated through a series of gears from an operating crank on the side of the assembly and which is rotated when the No. 2 armature moves either in a trip direction or in a reset direction. The degree of time delay of this device can be adjusted within three time delay bands by changing the effective length of the lever arm of the crank.

The front face of the trip device is covered by an insulating cover which carries the adjusting means and indicators for the trip device. A nameplate mounted on the front of this cover indicates the calibration markings. Each armature carries an adjustable trip screw which engages the circuit breaker tripper bar when the armature has completed its upward stroke. A flexibly supported weight mounted on the No. 1 armature is used to minimize the pulsations of the magnetic forces due to the alternating character of the load current and serves to reduce noise and wear from the armature vibrations.

The above elements of the overcurrent trip device may be combined in different forms to obtain various operating characteristics of the overcurrent trip device to suit the requirements of a given application. These different combinations are indicated in the following Table I.

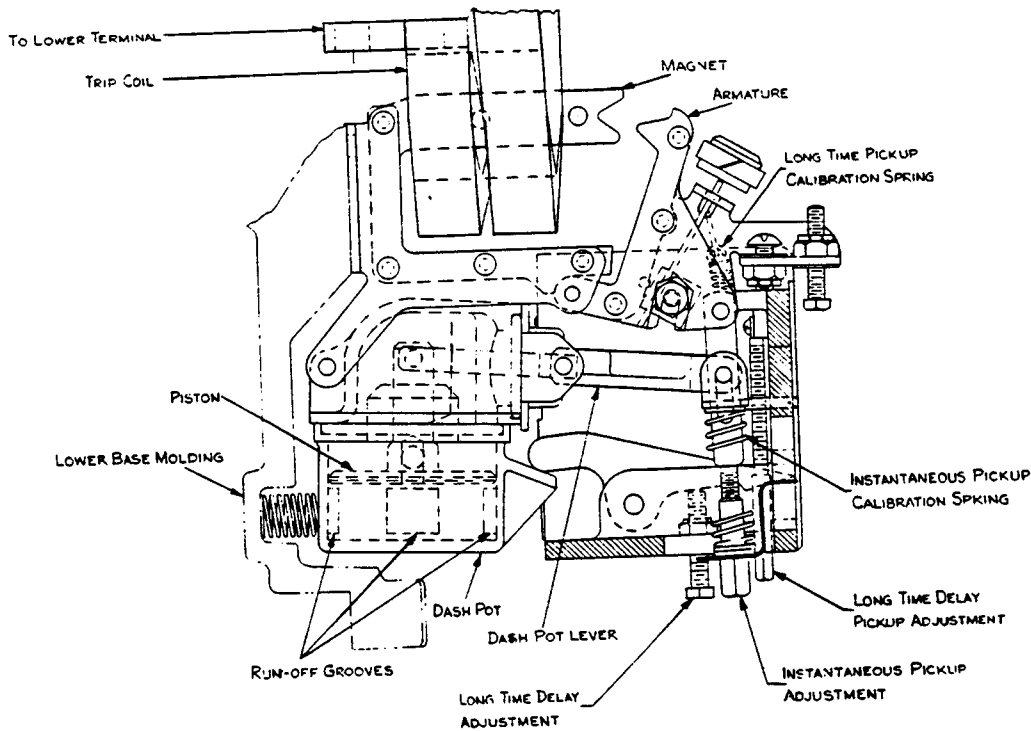

TABLE I
TYPES OF OVERCURRENT TRIP DEVICES

Type Designation	Functional Description	Time-Current Characteristic Curve Numbers	Calibration Range			Components			
			Long Time Pickup (in per cent Rating)	Short Time Pickup (in per cent Rating)	Instantaneous Trip Pickup (in per cent Rating)	Fluid Displacement Dashpot	Mechanical Escapement Timer	Armature No. 1 (Broad)	Armature No. 2 (Narrow)
OD-3	Dual Magnetic (General Purpose)	*TD-5523	See TD Curve Chart			Yes	No	Yes	No
OD-4	Dual Selective (Without Instantaneous)	*TD-5524	80 to 160	500 to 1000		Yes	Yes	Yes	Yes
OD-5	Dual Selective (With Instantaneous)	*TD-5525	80 to 160	500 to 1000	500 to 1500	Yes	Yes	Yes	Yes
OD-6	Dual Magnetic (Special)	*TD-5526	80 to 160	—	500 to 1500	Yes	No	Yes	Yes
OD-7	Instantaneous Trip (High Range)	†	—	—	500 to 1500	No	No	No	Yes
OD-8	Instantaneous Trip (Low Range)	†	—	—	80 to 250	No	No	Yes	No
OD-9	Selective Trip Only (With Instantaneous)	TD-5529	—	500 to 1000	500 to 1500	No	Yes	Yes	Yes
OD-10	Selective Trip Only (Without Instantaneous)	TD-5520	—	500 to 1000	—	No	Yes	No	Yes

* Reproducible copies TD curve numbers available upon request.

† Curves are not available.



(Drawing No. S-14713)

Fig. 1

Mechanical diagram of OD-3 dual magnetic (general purpose) overcurrent trip device for K-Line Circuit Breakers



OVERCURRENT TRIP DEVICE

Type EC-2
For Type AK-1-15,
AK-1-25 and AK-1-50
Air Circuit Breakers

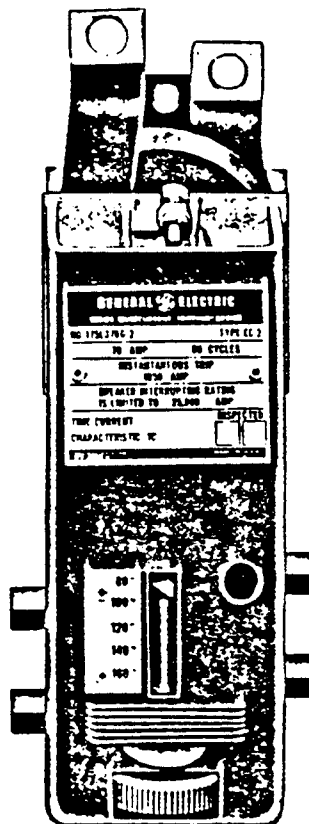

LOW VOLTAGE SWITCHGEAR DEPARTMENT
GENERAL  **ELECTRIC**
PHILADELPHIA, PA.

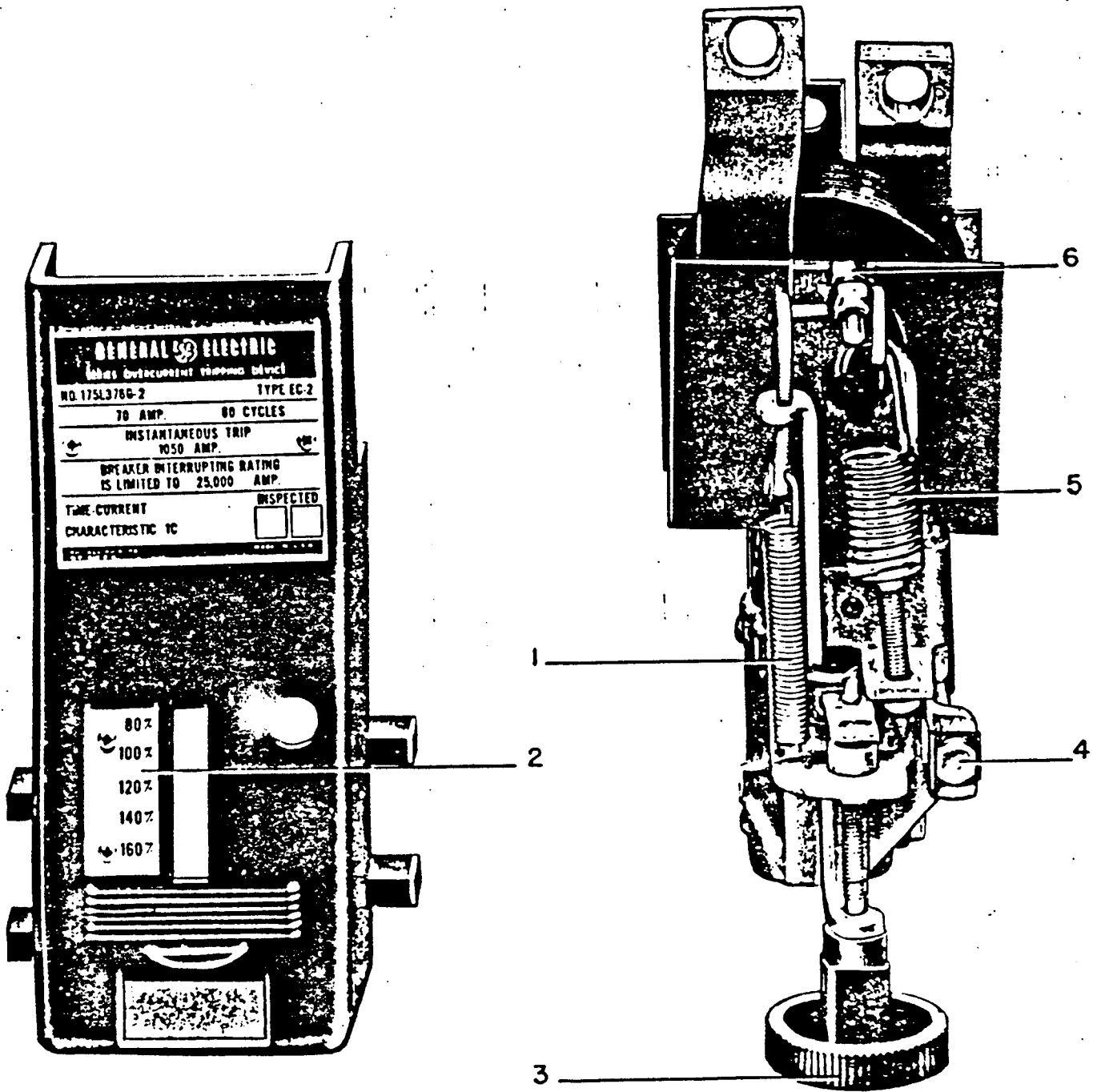

cover (A010486)

- 1. Long-time-delay Calibration Spring
- 2. Calibration Plate
- 3. Adjustment Knob

- 4. Time Adjustment Screw
- 5. Instantaneous Trip Spring
- 6. Trip Screw

Fig. 1 EC-2 Device - Cover Removed

SERIES OVERCURRENT TRIPPING DEVICE TYPE EC-2

The Type EC-2 overcurrent tripping device is available in three forms:

1. Dual overcurrent trip, with long-time delay and high-set instantaneous tripping.
2. Low-set instantaneous tripping.
3. High-set instantaneous tripping.

The dual trip has adjustable long-time and instantaneous pick-up settings and adjustable time settings. Both forms of instantaneous trips have adjustable pick-up settings.

DUAL OVERCURRENT TRIP, WITH LONG-TIME DELAY AND HIGH-SET INSTANTANEOUS TRIPPING

By means of the adjustment knob (3), figure 1, which can be manipulated by hand, the current pick-up point can be varied from 80 to 160 percent of the series coil rating. The indicator and a calibration plate (2), figure 1, on the front of the case provide a means of indicating the pick-up point setting in terms of percentage of coil rating. The calibration plate is indexed at percentage settings of 80, 100, 120, 140 and 160.

As in the case of the EC-1 overcurrent trip, the long-time delay tripping feature can be supplied with any one of three time-current characteristics which correspond to the NEMA standards maximum, intermediate and minimum long-time delay operating bands. These are identified as 1A, 1B and 1C characteristics, respectively. Approximate tripping time for each of these, in the same order are 30, 15 and 5 seconds at 600% of the pick-up value of current. (See time-current characteristic curves 286B201A, B and C.)

The tripping time may be varied within the limits shown on the characteristic curves by turning the time adjustment screw. (See figure 3.) Turning in a clockwise direction increases the tripping time; counter-clockwise motion decreases it. The dashpot arm (2), figure 3, is indexed at four points, MIN.-1/3-2/3-MAX., as indicated in figure 2. When the index mark on the connecting link (3), figure 3, lines up with a mark on the dashpot arm, the approximate tripping time as shown by the characteristic curve is indicated. The 1A and 1B characteristic devices are shipped with this setting at

the 2/3 mark and the 1C characteristic at the 1/3 mark. The standard characteristic curve are plotted at these same settings.

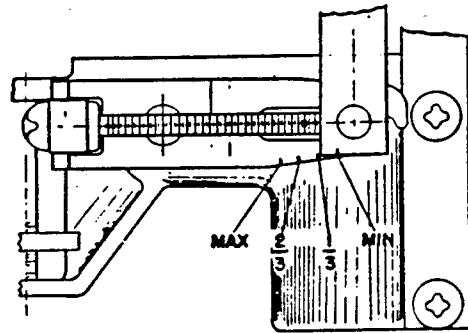

Fig. 2 Time-Adjustment Indexing

Time values are inversely proportional to the effective length of the dashpot arm. Therefore the linkage setting that gives the shortest time value is the one at which dimension "A", figure 1 is greatest. The time adjustment screw (4), figure 1 may be turned by inserting a Phillips head screw driver through the hole in the front of the case but if it is desired to relate the linkage setting, the index marks on the linkage it will be necessary to remove the case. This may be done by removing the two mounting screws, one on each side of the case, which may be taken off without disturbing the trip unit itself.

If the breaker is of the AK-1-15 type and provided with a shunt trip or undervoltage device the EC-2 case on the center pole must be taken off first before the cases on the outer poles can be removed.

INSTANTANEOUS LOW-SET TRIPPING

The low-set instantaneous pick-up point may be varied by the adjustment knob (3), figure 1. The calibration in this case usually ranges from 80% to 250% of the series coil rating, the calibration plate being indexed at values of 80%, 100%, 150%, 200% and 250% of the rating.

These instructions do not purport to cover all details or variations in equipment nor to provide for every possible contingency to be met in connection with installation, operation or maintenance. Should further information be desired or should particular problems arise which are not covered sufficiently for the purchaser's purposes, the matter should be referred to the General Electric Company.

Fig. 2 (417464)

INSTANTANEOUS HIGH-SET TRIPPING

The high set instantaneous pick-up value may have one of the following three ranges: 4 to 9 times coil rating; 6 to 12 times coil rating or 9 to 15 times coil rating. The pick-up setting may be varied by turning the instantaneous trip adjusting screw, see figure 4.

Three calibration marks will appear on the operating arm at (3) figure 4 and the value of these calibration marks will be indicated by stampings on the arm as follows:

4X		6X		9X
6.5X	or	9X	or	12X
9X		12X		15X

At the factory, the pick-up point has been set at the nameplate value of the instantaneous trip current. (Usually expressed in times the ampere rating of the trip coil). The variation in pick-up setting is accomplished by varying the tensile force on the instantaneous spring. Turning the

adjustment screw changes the position of the movable nut (2) figure 4 on the screw. The spring is anchored to this movable nut so that when the position of the nut is changed, there is a corresponding change in the spring load. As the spring is tightened, the pick-up point is increased. The edge of the nut serves as an index pointer and may be lined up with the proper calibration mark to give the desired instantaneous trip value.

The trip screw (6) Fig. 1 on the end of the armature should be set so that it does not contact the trip paddle on the trip shaft until the air gap between armature and pole piece is reduced to 3/32 of an inch or less, measured at the rivet in the pole piece. Also, the armature must have a minimum of 1/32 of an inch of travel beyond the point in its motion at which the breaker is tripped.

When replacing an EC-1 device with an EC-2, it will be necessary to replace the trip paddles on the trip shaft with ones which are slightly longer. These will be provided with the replacement trip units.

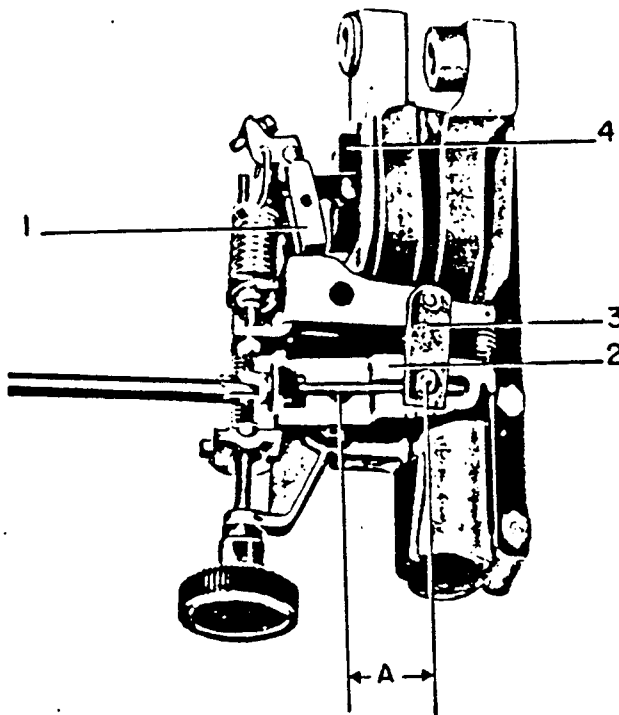

- 1. Armature
- 2. Dashpot Arm
- 3. Connecting Link
- 4. Pole Piece

Fig. 3 Method Of Making Time-Delay Adjustment

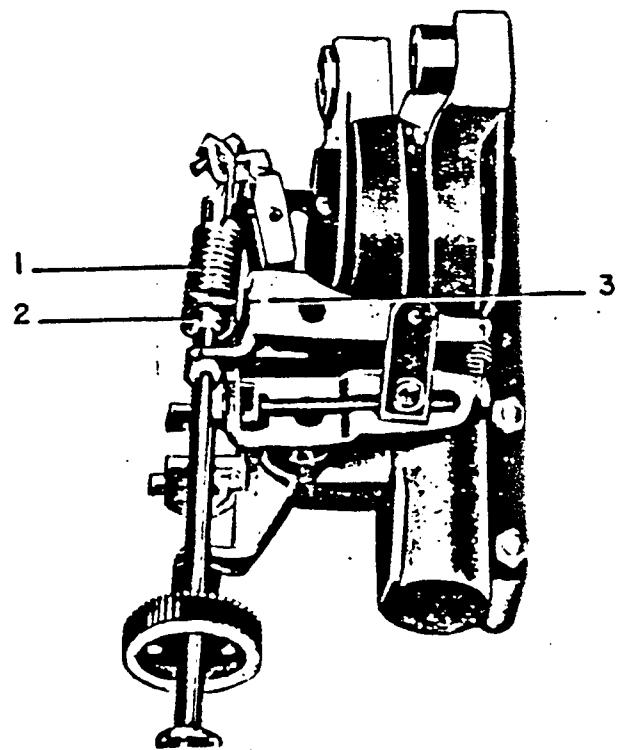

- 1. Instantaneous Trip Spring
- 2. Movable Nut
- 3. Reference Mark

Fig. 4 Method Of Making High-Set Instantaneous Pick Up Setting Adjustment



INSTRUCTIONS

GEI-90892

**FIELD TESTING OF GENERAL ELECTRIC TYPE
OVERCURRENT TRIP DEVICES**

SWITCHGEAR PRODUCTS DEPARTMENT

GENERAL  ELECTRIC

PHILADELPHIA, PA.

missing

pg.

2

FIELD TESTING OF GENERAL ELECTRIC TYPE OVERCURRENT TRIP DEVICE

GENERAL

Increased interest in breaker maintenance is evident by the increase in field inquiries concerning maintenance procedures. Since the majority of these inquiries concern checking the operation of overcurrent trip devices, the following factory advice is offered as an aid to those involved in that activity.

Before attempting any checks or adjustments, the assigned tester should consult the maintenance manual to familiarize himself with the operating details of the specific breaker involved and the specific overcurrent trip device. He should be certain the power voltage has been removed. Prior to checking the overcurrent trip device, the breaker contacts, mechanism and trip latch should be checked to assure their proper functioning so that the breaker can carry the required current and that the trip shaft is free of high friction loads. The trip latch should be checked for proper trip latch engagement.

Overcurrent Trip Device Checks:

An adequate check to prove the overcurrent trip device functions properly consists of a mechanical check followed by an overcurrent operation.

Mechanical Check:

A careful mechanical check should be made of any magnetic overcurrent trip device to assure a successful tripping operation just before the armature reaches the fully closed air gap condition. This can be done by manually pushing the armature toward the closed air gap position, and determining how much further the armature moves after the breaker has tripped. This check to assure "positive trip" is within the tolerance specified in the breaker maintenance manual is important and can affect the apparent degree of time delay during a subsequent overcurrent timing test. If there is insufficient "positive trip" the armature may "bottom" on the magnet pole face without sufficiently displacing the trip latch. Slightly excessive "positive trip" may cause fast tripping while extremely excessive "positive trip" will allow the trip device armature to be loaded by the latch when the air gap is excessive. When the air gap is excessive, tripping force is at a low level compared to the force at short air gaps and the device may tend to stall or "ride the latch".

The armature of the EC-2, EC-2A, EC-1A and EC-1B of the AK breakers and the oil film (sticky disk) and Grade "B" time of AL-2 type breakers can be manipulated directly while observing the tripping. On the EC-1 device the trip arm is not fastened to the armature. To accurately determine the degree of positive trip on the EC-1, it is necessary to "probe" the armature through the holes provided in the case. A drill rod or short length of stiff wire will serve as a probe. Maintenance manuals for the specific breaker shows the procedure in detail.

While checking positive trip, the armature should be held in the tripped position sufficiently long to assure the time delay escapement is operative as follows:

- a. As the armature is pushed to the closed air gap position, devices with instantaneous trip features will allow the instantaneous trip spring to stretch and allow temporary separation of the armature from the time delay dashpot. Maintaining the armature in the closed air gap condition will cause the instantaneous spring to pull the dash pot through its timing stroke. Devices with long delay characteristics will require considerable time to "time out." Failure of the dashpot

to move at all warrants further investigation to see if a bind exists in the dashpot or connecting linkage.. Similarly, lack of any time delay (when the device is so equipped) or a very fast "time out" will generally indicate lack of oil and again further investigation is warranted.

- b. When releasing the armature after the device has "timed out" check the armature to be sure it returns to the fully open gap position and rests on the armature open air gap stop. An armature hanging half-way closed indicates a possible bind in the armature pivot or dashpot or possibly the pick-up setting has been reduced so far below the minimum setting that the calibration spring no longer provides re-setting torque. Binds in the armature pivot of devices employing oil displacement type dashpots are generally detected by the armature failing to fully reset following a partial "timing out" operation (such as may occur from a motor starting operation). On the next overload the partially closed air gap causes premature tripping. (Generally considered a fail safe condition.)
- c. Visually check for missing hardware, clamping devices, evidence of leaking oil, broken cases, cracked breaker trip paddles. On oil film (sticky disc) devices and Grade B timers, the condition of the oil should be observed and changed if necessary. See maintenance manual for acceptable cleaning methods and type of oil.

Overcurrent Check:

If desired, an overcurrent test can be made to assure the breaker will trip on overcurrent. The purpose of overcurrent testing of trip devices in the field should be to determine if the breaker will perform as required for that circuit to which it is applied. Since the trip device exhibits its lowest trip force levels when encountering low levels of overcurrent, an indication of adequate trip device performance can generally be assured by making an overcurrent check at approximately 150 to 300 percent of coil rating as shown in Table I. On dual magnetic trip devices, the armature and pivot pin is common to both the long time delay feature and the instantaneous trip. If the force generated across the air gap is sufficient to attract the armature for slight overcurrents in the long time region, tripping on short circuit by the same armature is assured. As the armature times toward the closed air gap position, the force across the air gap increases high enough to stretch the instantaneous spring and exercise the instantaneous trip parts. Similarly, the short time armature on selective trip devices is on the same pivot as the long time armature and the iron structure is comparable. Therefore, checking the long time delay feature affords reasonable assurance of all features successfully performing their trip functions. The long time delay pick-up should be set at 100% current.

Overcurrent Test Equipment:

In addition to being capable of producing current levels approximately 300% of trip coil rating, the current must be reasonably sinusoidal. Since overcurrent trip devices are designed to saturate slightly above continuous rating to avoid destructive forces at short circuit levels of overcurrent, the devices represent a non-linear impedance at current levels recommended for time delay testing. If the trip device represents the predominant impedance in the test circuit, a non-sinusoidal current wave shape results. To maintain a reasonably sinusoidal wave shape of current, air core reactance should be inserted in the series circuit. The air core reactance must represent the predominant reactive (and linear) impedance to minimize the effect of the trip device impedance. Insertion of this additional impedance in turn requires an increase in test voltage. The minimum external impedance requirement varies for each coil size. The smaller the rating of the trip coil, the higher becomes its impedance, the more external impedance is required, hence the higher the required source voltage. Rather than specify the external impedance required for each coil rating, it is more convenient to indicate the open circuit voltage required for various coil ratings. The

external impedance can then be inserted as required to control the test current. Figure 1 shows these open circuit voltage requirements for various coils. This voltage can be quickly checked after the current has been set by measuring the voltage with the breaker open and the test set "on" at the level required to produce 300% continuous current.

Test Procedure:

1. With a test set meeting the minimum requirements outlined above and connected securely to the upper and lower studs of one pole of the breaker, set the long time pick-up setting on the trip device to 100%. The relative position of the adjustable time setting of EC-2 type devices should be noted. It is important that time adjusting screw is not forced to the limit of its travel; otherwise binding of the time delay linkage may result.
2. Close the breaker and adjust the current to the degree of over-current listed in Table I for the particular O. C. trip device.
3. Shut off the test set to allow the device to re-set.
4. Re-apply the power and record the trip time in the appropriate test log book.

If repeat tests are attempted, it will be necessary to allow a sufficient cooling time between tests so as not to exceed the thermal capacity of the circuit breaker.

The magnets of some overcurrent trip devices are oriented in such a direction that the flux across the air gap of the device of one pole effects the pick-up of the devices on adjacent poles. Generally, these breakers have correction factors applied to their single phase calibration currents to assure adequate performance when applied on 3 phase circuits. These correction factors should be similarly applied when field checking. Notes on Table I indicate the correction factors to be applied. Test data should be compared with acceptable or specified limits so that discrepancies can be verified immediately.

On completion of the overcurrent trip device test, it is important to carefully reassemble any accessories that were removed to facilitate the overcurrent trip device test or adjustments. Any adjustments to those accessories should be made as directed by the maintenance manual. Careless reassembly of accessories may result in subsequent serious damage to the breakers and the circuits they protect.

Test Results:

The trip time measured for the trip device at the recommended overcurrent condition should be compared with the factory trip curve for new devices. In view of the wide variation in the parameters responsible for the apparent degree of time delay from a trip device, tripping times will often exceed the band width shown on the characteristic curves. These variations can be caused by variations in the current wave produced by test equipment, wide deviations in ambient temperature or high oil temperature caused by repetitive testing. Field adjustments, if necessary, should be confined within the adjustable range designed into the device for field adjustments. Replacement parts (other than cases or clamping hardware) are not generally available for overcurrent devices. When replacement devices are required, complete nameplate information extracted from the overcurrent trip device and the involved breaker should accompany the order.

TABLE I

<u>Breaker Type</u>	<u>Type Overcurrent Trip Device</u>	<u>Test Current in Percent of L.T.D. Pick-up *</u>
AL-2	Oil film (sticky disc) Grade B	150 150
AK-15/25/50	EC-1	150
AK-15/25/50	EC-2, EC-2A (inst. 4X)	150
AK-15/25/50	EC-2, EC-2A (inst. 6X or higher)	300
AK-1-75-100	EC-1	150 **
AK-2-75-100	EC-1A, EC-1B	150 ***

* Pick-up set at 100% of trip device rating.

** Characteristics having XX suffixes should have 147% correction factored into current. Correction factors for YY characteristics are 160% on left and right poles and 187% on center poles.

*** Correction factors of 93 and 107% for left and right poles respective must be factored into test currents.

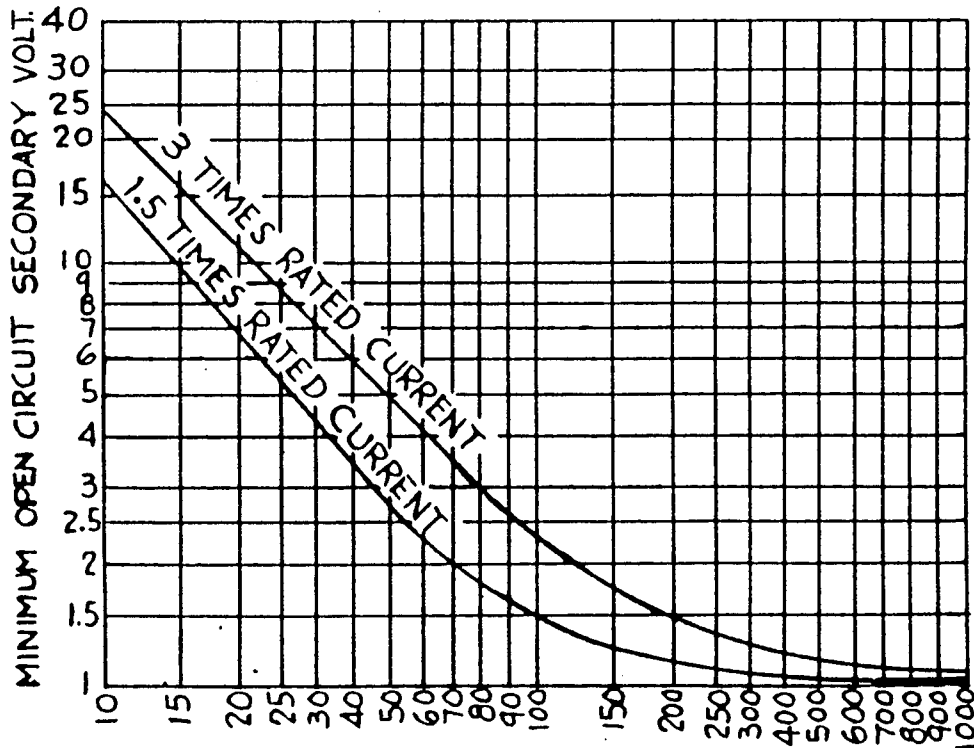

AMPERE RATING OF TRIP DEVICES

FIG-1



INSTRUCTIONS

GEK-7309B
Supersedes GEK-7309A

**TEST INSTRUCTIONS FOR INSTALLATION
OR SERVICE OF**

POWER SENSOR* TRIP DEVICE

Used on AK Type Low Voltage

Power Circuit Breaker

* Registered Trademark of General Electric Co.

SWITCHGEAR PRODUCTS DEPARTMENT

GENERAL  ELECTRIC

PHILADELPHIA, PA.

CONTENTS

OBJECTIVE 3

 A. Directed toward GE I & SE, GE Service Shops, OEMs and Contract Testers.

 B. To be used as an aid in installing AK Breakers equipped with Power Sensors.

 C. To be used by them as an aid in locating the problem area when a particular breaker is suspected of improper operation.

GENERAL INFORMATION 3

TEXT 3

 A. Inspection 3

 B. On Site Power Sensor System Check 4

 C. Servicing of AK Power Sensor Breakers 8

TABLES AND CHARTS 9

QUICK-CHECK LIST 9

These instructions do not purport to cover all details or variations in equipment nor to provide for every possible contingency to be met in connection with installation, operation or maintenance. Should further information be desired or should particular problems arise which are not covered sufficiently for the purchaser's purposes, the matter should be referred to the General Electric Company.

POWER SENSOR* TRIP DEVICE

Used on AK Type Low Voltage

Power Circuit Breaker

OBJECTIVES

This instruction book is intended to serve as a supplement to the Maintenance Manuals for Low Voltage Power Circuit Breakers, and the Instructions for the Power Sensor Test Set, GEK-7301, used to check the Power Sensor trip device. It is meant to be used by GE I&SE, GE service shop, OEM, and contract tester personnel as an aid in installing AK type breakers equipped with Power Sensors, and as an aid in locating the problem area when a particular breaker is being serviced.

GENERAL INFORMATION

Before attempting any checks or adjustments, the tester must consult the maintenance manuals for the breaker to familiarize himself with the operating details of the specific breaker involved and the Power Sensor overcurrent trip device. He should disconnect the breaker from the primary power bus. Prior to checking the trip device the breaker contacts should be inspected and the mechanism and trip latch should be checked for proper functioning to verify that the breaker can suitably carry the required current. The trip shaft should be free of high friction loads. The trip latch should be checked for proper trip latch engagement and torque.

The Power Sensor trip device employs a peak reading circuit and responds to the magnitude of current in the primary phase carrying the largest current. Therefore, a non-sinusoidal current may result in what appears to be an erroneous operation of the Power Sensor system if RMS meters are used to measure the non-sinusoidal signal and the trip device responds to the peak of the signal. The peak and the RMS value of non-sinusoidal signals are not related as they are for perfect sine waves.

In high current, low voltage test circuits one of the major causes of waveform distortion is the non-linear breaker impedance. To maintain a reasonably sinusoidal current waveshape, air core reactance equal to approximately 20 microhenries should be inserted in the test circuit in series with the breaker for AK-25, 75 and 100 breakers. (No reactance is needed for AK-50 breakers unless it is rated 200-600A.)

This reactance is not needed when operating from the power system because the current is produced by a source with sufficient voltage to maintain a sinusoidal current waveform. The

output current of a high current-low voltage test set which uses a variable voltage transformer will follow the primary voltage. The current may not be sinusoidal, when the Power Sensor trip device is its load, due to the reduced voltage at the zero crossing of the current waveform. Air core reactance shifts the phase angle between the voltage and current so that at current zero the voltage will be large enough to maintain the rate of change of current needed for a sinusoidal current waveform.

Some problems may occur while testing logic units removed from breakers stored in high humidity areas. The test results may become erratic and not agree with published curves and tolerances. This can be due to a high moisture content on the surface of the logic unit's circuit boards in de-energized equipment.

This test problem has been solved by removing the logic units to a warm dry area for about an hour prior to testing. Once the breaker is carrying current, the normal elevated temperature within its compartment is enough to eliminate the effects of this high humidity environment.

Additional information that should be available during test includes:

1. Drawings #133C9017, #133C9018 and #138B2454 on pp. 11, 12 and 13.
2. GEK-7301 - Power Sensor Test Set Instructions.
3. GEK-7303 - Breaker Maintenance Manual (AK-3-50/75/100)
4. GEK-7310 - Breaker Maintenance Manual (AK-5-50)
5. GEI-50299 - Breaker Maintenance Manual (AK-25).
6. GEZ-4431 - Packet of Time Current Curves.

INSPECTION

Check the following items against the specified settings for the particular breaker application when they apply.

1. The sensor CT taps should be set at the correct current rating on all three phases. These taps must be secure. The Power Supply rating disc should also be set to the correct current rating. (See Figure 1 and Figure 3).

2. The tap selector knobs on the Power Sensor unit should be set to the correct pickup and time delay settings for the application intended. These knobs must be secure. (Figure 2)
3. The magnetic trip device must be connected to the terminal block on the power supply. (Figure 3)
4. Check that both plug connections are secure. (Figure 3).

will perform as required for the circuit to which it is connected. A Power Sensor test set, type PST-1, can be used to check all operations of the system except the breaker mounted CT's which can be checked for continuity with an ohmmeter.

Since the CT's are checked at numerous points during the assembly process, a continuity check showing that the resistance of the CT on one pole agrees with the resistance of the similar CT on the other two poles is sufficient.

When performing single phase checks on the ground fault equipped breakers, it is necessary to short terminals one and five at the ground signal terminal board on the back frame of the breaker. Shorting of the ground signal must be a high integrity connection since voltages in the range of .25 volt peak will cause operation of the ground fault circuit. Terminals one and five can be identified by the .15 micro-farads capacitor connected between them. (See Figure 4)

The following equipment will be necessary to make overcurrent tests:

ON SITE POWER SENSOR SYSTEM CHECK
(High Current-Low Voltage Tests)

The check-out of AK type Power Sensor breakers at the time of installation includes a visual inspection as shown under the section titled "Inspection", page 3.

In some cases an on the site check of the breaker under overcurrent conditions is necessary. The purpose of overcurrent testing of trip devices in the field should be to determine if the breaker

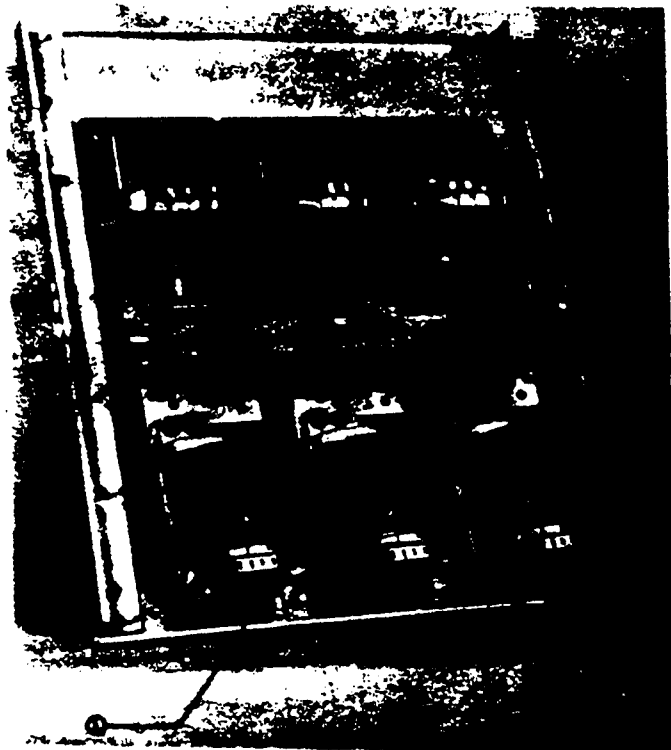

Figure 1. (8041487) Backframe for AK-3-50 Breakers showing Coil Assembly

1. Sensor CT taps
2. Disconnect plug

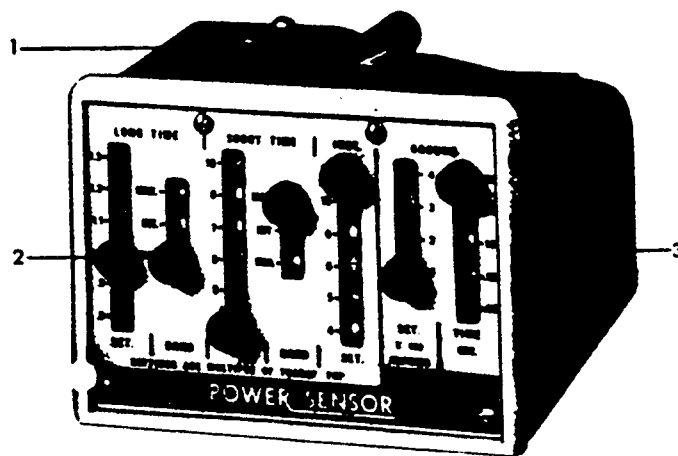

Figure 2. (8039649) Power Sensor Unit

1. Mounting Screw
2. Tap Selector Knobs
3. Name Plate

1. A high current-low voltage test set and a suitable timer.
2. A type PST-1 test kit.
3. A Volt-ohm-milliammeter (in good calibration).
4. A 20 micro-henry air core reactor.

CAUTION

THE POWER SENSOR TRANSFORMER TAP SELECTORS MUST BE CONNECTED AT ALL TIMES ON ALL PHASES. THE DISCONNECT PLUG CONNECTING THE FRONT FRAME WIRING TO THE BACK FRAME WIRING MUST BE CONNECTED BEFORE ENERGIZING THE POWER CIRCUIT. FAILURE TO ENSURE CONNECTIONS WILL RESULT IN DAMAGE TO THE COILS.

Adequate overcurrent testing at installation would include one overcurrent trip on each pole of the breaker using the lowest set function that has been supplied on the particular Power Sensor system. On breakers equipped with the Ground function a Ground trip test should also be performed. The suggestion to alternate the pole of the breaker used in the test is made to ensure that the output of each breaker mounted CT is tested. For example, a Power Sensor system supplied with Long Time Delay, Short Time Delay, and Ground Fault detection could be tested at its Long Time Delay setting, as received, on each pole of the breaker and at its Ground Fault setting as received.

The following methods can be used in making the appropriate test at installation. Included are:

- Long Time Delay Test - Timing or,
- Short Time Delay Test - Pickup or,

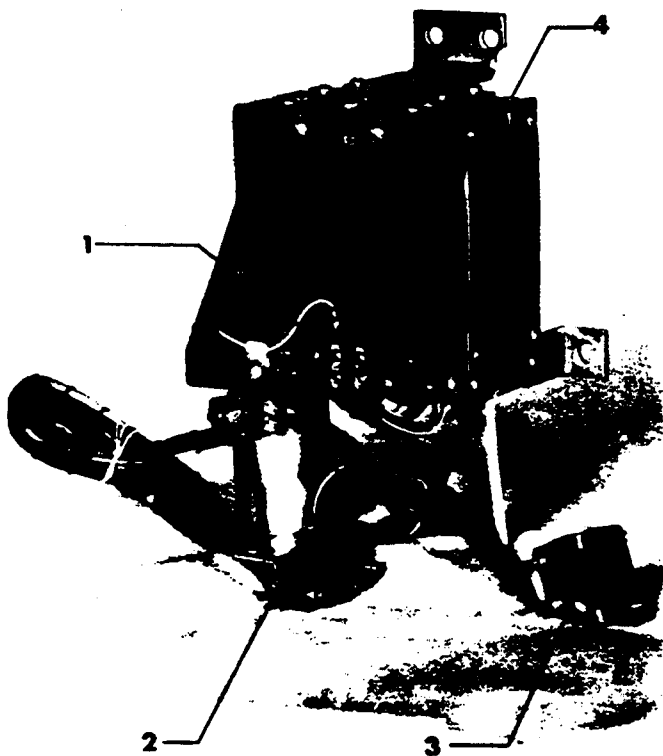

Figure 3A. (8041488) Power Supply AK-50, 75 and 100 Breakers

1. Terminal Block
2. Male Disconnect Plug
3. Female Disconnect Plug
4. Rating Disc

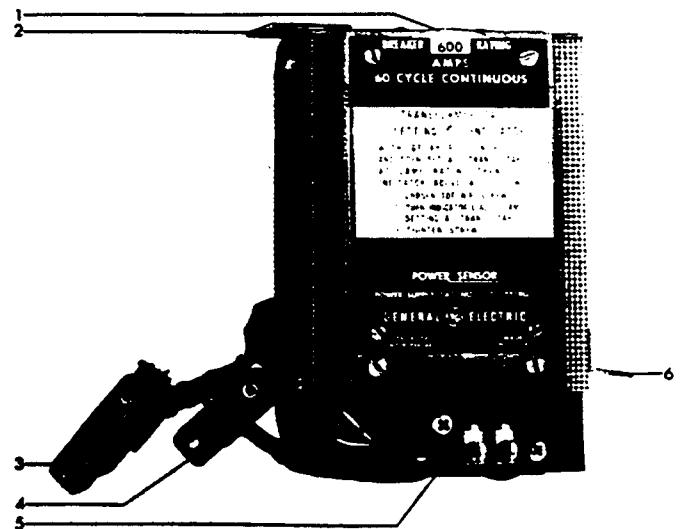

Figure 3B. (8039850) Power Supply AK-25

1. Rating Disconnect
2. Mounting Bracket
3. Male Disconnect Plug
4. Female Disconnect Plug
5. Terminal Block
6. Mounting Bracket

GEK-7309 Test Instructions - Power Sensor Breakers

**Instantaneous Trip Test - Pickup and
Ground Fault Detection - Pickup, if included.
100 Volt Bus Test**

LONG TIME DELAY TEST - TIMING

Power Sensor Settings:

LTD set for the particular breaker application.
All other trip functions set to maximum settings.

With the test truck connected to one pole of the breaker, apply test current equal to some convenient multiple of the CT tap setting. 300% of the CT tap setting is suggested because this one test point is adequate to ensure proper operation of the trip device. The trip times at this

test point are not too long and the test currents do not result in severe duty to the test equipment. (It must be remembered that repeated testing at high multiples of the continuous current rating will cause heating of the breaker contacts, and increased contact wear.)

Trip time at 3X current as found on the time current curves is:

MIN = 25 sec ± 20%, INT = 75 sec ± 20%
MAX = 150 sec. ± 20%. The (X) is in multiples of the CT tap setting and is independent of the LTD pickup setting on the logic unit.

The LTD circuit operates so that the trip



Figure 4 (8041489) Ground Signal Terminal Board (AK-3-50 shown).

- 1. Terminal Board
- 2. Sensor CT taps

time is equal to a constant divided by the current squared, $t = K/I^2$. A small variation in the actual test current ($\pm 5\%$) could, therefore, result in a $\pm 10\%$ additional variation in time.

The breaker should trip within the time band specified in the appropriate time-current curve when the comments in the above paragraph are considered. Repeat this test on the two remaining poles of the breaker.

NOTE: When testing AK-75 and AK-100 breakers it has been found that tests using the 1500A or 2000A CT tap are more convenient to make. No compromise in timing results will occur. (remember to return all pick-up and CT tap settings to the setting specified for the particular breaker application.)

SHORT TIME DELAY TESTS - PICKUP

If the breaker is not equipped with LTD but is equipped with STD, a test at 110% of the STD pickup setting is adequate to insure proper operation. (If timing is to be checked, use 200% of the pickup setting to avoid the "knee" of the time current curve).

Power Sensor Settings:

STD set for the particular breaker application. All other trip functions set to maximum settings.

With the test truck connected to one pole of the breaker apply test current equal to 110% of the Short Time pickup setting. Observe that the breaker trips. Repeat this test on the two remaining poles of the breaker. Test current should be raised slowly until tripping occurs so that the tester can make note of the trip current level.

INSTANTANEOUS TRIP TESTS

If the breaker is equipped with LTD or STD it is not necessary that the Instantaneous function be tested at the time of installation. If it is desired to test the Instantaneous function it is important that the STD pickup setting be set above the Instantaneous trip setting or the breaker will open at the STD setting before the Instantaneous setting is reached. (There is a noticeable difference between the trip time for a breaker which opens at the STD MAX time setting and one that opens at the Instantaneous trip level. This difference in time will allow testing of overlapping settings such as 12X CT tap setting when the STD is set to 10X. This is not the normal method of testing the Instantaneous function.)

Power Sensor Settings:

STD set above the Instantaneous setting. Instantaneous set to 4X. All other functions set for the particular breaker application.

With the test truck connected to one pole of the breaker apply test current equal to 110% of the Instantaneous pickup setting. Observe that the breaker trips. Repeat this test on the two remaining poles of the breaker. Test current should be raised slowly until tripping occurs so that the tester can make note of the trip current level.

The 4X setting is suggested for this test because at higher current levels repeated testing can result in heating of the breaker contacts and increased contact wear.

GROUND FAULT TESTS

Remove the jumper between terminals one and five. (On four wire systems only, place the jumper so that it simulates a short on the fourth wire CT. This jumper should be placed between the white lead and black lead of the twisted shielded pair at the disconnect plug.) Perform a continuity check as described on drawing 138B2454, page 13 of this manual.

Power Sensor Settings:

All functions should be set for the particular breaker application.

With the test truck connected to one pole of the breaker, raise the current slowly and note the level at which the breaker trips. Compare this level with the trip setting. Trip current should be within -20%, + 0% of the set point, however, the ground sensing function is sensitive to the rate of change of current and ground tripping that does not vary more than -30%, +10% from the setting should be considered acceptable. Repeat this test on the two remaining poles of the breaker.

On completion of these tests, remove any temporary jumpers. Perform a continuity check on the Ground circuit using drawing 138B2454. This can be done by disconnecting the 14-socket plug at the Power Sensor Unit, opening the breaker, and racking the breaker to the CONNECT position. Use an ohmmeter to perform a continuity check from point A to C, the circuit contains the ground sensor coils in series and should be continuous. Check continuity from A to R, an open circuit must appear.

The shielding must be continuous and can be checked on 4-wire systems by placing a temporary jumper at the 4th wire CT (in the neutral bus) from the black wire to the shield. With this jumper in place, continuity should exist between C and R when checked at the Power Sensor plug. Remove the jumper at the 4th wire CT, check at the plug for an open circuit between C and R. This establishes continuity of the shield from the plug to the 4th wire CT. On three-wire systems continuity of the shield can be checked by going from R at the plug directly to the shield at each Ground sensor CT.

Before the breaker is placed in service, the sensor CT taps must be set to the correct rating on all three phases. The tap selector knobs on the Power Sensor unit must be correctly set for the particular breaker application, and all disconnect plugs should be connected. Failure to ensure connections will result in damage to the coils.

Polarity of the ground sensor CT should be checked on 3-wire and 4-wire systems to make sure that the white polarity mark on the CT, near the position where the leads are connected, is the way from the source in the standard breaker connection. (On reverse fed breakers the 4th wire CT should be installed so that the white polarity mark is toward the source.)

100 VOLT BUS TEST

This test can be performed in one of two ways: (a) using a high current test or (b) using the Power Sensor test set.

When using the high current, you must pass at least 20% to 30% of the breaker maximum current rating. This must be done on each phase. Close the breaker. With a d.c. Voltmeter, check for 100 volts d.c. at terminals of 110 mfd. Electrolytic Capacitor. This capacitor is located on the bottom of the Power Sensor power supply, or the bottom left corner of the back frame. Instructions for using the test set to perform this check are in Instruction Book, GEK-7301.

SERVICING OF AK POWER SENSOR BREAKERS

When a Power Sensor equipped low voltage circuit breaker is suspected of improper operation, it will fall into one of the following three classes: breaker fails to open, breaker fails to close, or breaker opens when it should not do so. It is important to first ascertain that the malfunction is caused by the Power Sensor System. Mechanical interlocks, intermittent secondary disconnects, sneak shunt trip circuits, or inadvertent acts by personnel must be removed as a possible cause of the problem.

Shown below and outlined in Chart I are the steps recommended for locating the faulty item.

IF THE BREAKER WILL NOT OPEN

Perform high current-low voltage tests as described under "On Site Power System Check" on Page 4 of this manual. Proper operation during this test should direct the tester's attention to the power system and the breaker enclosure. Check the power system load for any unusual conditions that could be misinterpreted by the Power Sensor. Check the breaker enclosure.

For analysis of distribution system problems in special situations a Load Analyzing Test Cable is available for use by qualified General Electric Company personnel. (Catalogue number 152C2748). This cable presents the pins in the connection

plug between the power supply section and the logic unit, shown on drawing 133C9018, Figure 7 page 12, so that the actual output of the CT's and the power supply can be displayed on an oscilloscope while the circuit breaker is in service.

If the power system and breaker enclosure check okay or if there is no operation during the high current-low voltage tests, check the breaker trip shaft for binds, check all trip paddles for correct alignment, and check all shunt trips and lockouts for misalignment or incorrect settings. Refer to maintenance manuals GEK-7303 and GEI-50299 for instructions. Mechanically check the shunt trip and Power Sensor solenoid trip devices to assure a successful tripping operation just before the armature reaches the fully closed position, manually push the armature toward the closed position and determine how much further the armature moves after the breaker has tripped. This check to assure "positive trip" is within the tolerance specified in the breaker maintenance manual is important.

If all shunt trips and lockouts are correctly set and aligned, perform a continuity check on the Power Sensor CTs. Refer to Drawing 133C9017 or 133C9018 on pp.11,12 of this manual. Measure resistances of similar coils on adjacent poles. Generally, if resistances balance the coils are good. For exact resistance values contact the factory. A satisfactory check of the CTs at this point would indicate an open Power Sensor connection plug or a problem with the Power Sensor itself. Use the Power Sensor test set and publication GEK-7301 and perform the described A and B Tests. The A Test will isolate the problem to the Power Sensor logic unit. The B Test will identify a power supply, trip relay, or cabling problem. Replace any section found defective by these tests. If no trouble is found, call the factory for further assistance.

IF THE BREAKER WILL NOT CLOSE

Check the equipment interlocks for interference. Check the trip shaft for binds, check all trip paddles to assure that they are properly aligned. Check all shunt trip devices and all lockouts. Misaligned or improperly set lockouts will prevent the breaker from closing resulting in trip free operation. If the above checks are successful, check the closing mechanism of the breaker according to the breaker manual.

IF THE BREAKER OPENS WHEN IT SHOULD NOT

If the breaker is equipped with ground fault protection, determine whether the false tripping is the result of falsely answering an overcurrent trip or a ground trip signal. This may be determined by temporarily eliminating the ground trip function by shorting points one and five at the ground signal terminal board on the back frame of the breaker. Terminals one and five can be identified by the .15uf capacitor connected between them. (See drawing 138B2454, and Figure 4). With the breaker restored to

service and with the ground fault detector deactivated, establish whether there is false tripping due to phase currents. If the ground trip function is at fault check the connection of the ground sensor coils and the polarity indications according to the wiring diagram 138B2454, page 13.

Perform high current-low voltage tests as described under "On Site Power Sensor System Check" on Page 4 of this manual. In this case, it is necessary to test all functions that are supplied with the unit set to the setting for the particular breaker application. Proper operation during this test should direct the tester's attention to the power system and load to determine if actual problem conditions exist.

If improper operation persists, check the alignment of the trip shaft, trip paddles, shunt trips and lockouts. Correct any misalignment or binds. Check the CT taps on the sensor CT tap selector board at the coil assembly to make sure they are connected and securely set at the correct ampere rating. Recheck the ground coil wiring.

Check all plug connections according to 133C9017 or 133C9018 on pp.11, and 12 of this manual. If open, check for damage and check continuity at both plugs. Change the appropriate section to replace the defective plugs. If the plug connections are secure, use publication GEK-7301

to perform the test designated A - test for the Power Sensor System. If the logic unit is bad, replace the logic unit; if good, perform the B test. With the Circuit Breaker open, set the "Signal Adjust" knob fully counter clockwise for a minimum level. Push Electrical "Reset" push Button and push "Start" Push Button.

With a d.c. Voltmeter, check for 100 volts d.c. at terminals of 110 mfd. Electrolytic Capacitor. This capacitor is located on the lower left corner of the backframe next to the CT disconnect plug on AK-3-25 breakers. On the AK-3-50/75/100 breakers, it is located on the bottom of the Power Sensor power supply. Measure this voltage on phase A, phase B and phase C by rotating the selector knob. If voltage does not lie between 95 and 115 volts d.c., the power supply is defective.

A defective system test at this point indicates a bad power supply section. Replace the power supply.

Once the trouble has been located and corrected using this method, the breaker should be placed in the test position and then opened and closed either manually or electrically. Proper operation will indicate that the problem condition has been corrected. Perform the inspection check as indicated on Page 3. The breaker can now be placed in service.

TABLES AND CHARTS

1. Trouble shooting and service diagram, Figure 5, Chart I, Page 10.
2. Power Sensor Cabling Diagram Drawing #133C9017 (Figure 6), and #133C9018 (Figure 7) on pages 11 and 12 of this manual.
3. Ground Fault System wiring drawing #138B2454 (Figure 8) page 13.
4. Time delay ranges for the Long Time Delay Circuit (GEK-7301 page 5).
5. Time overcurrent curves (Packet GEZ-4431).

QUICK CHECK LIST

1. Power Supply Rating disc is set at the correct current rating.
2. Coil taps are set at the correct current rating on all three phases.
3. Tap selector knobs on the Power Sensor Unit are set correctly.
4. All Power Sensor plugs are secure.
5. Shunt trip devices are correctly aligned to contact the trip paddles.
6. Wiring of Ground fault detection CTs, including the fourth wire CT, agrees with drawing #138B2454.

AK-3-25
POWER SENSOR TRIP CABLING

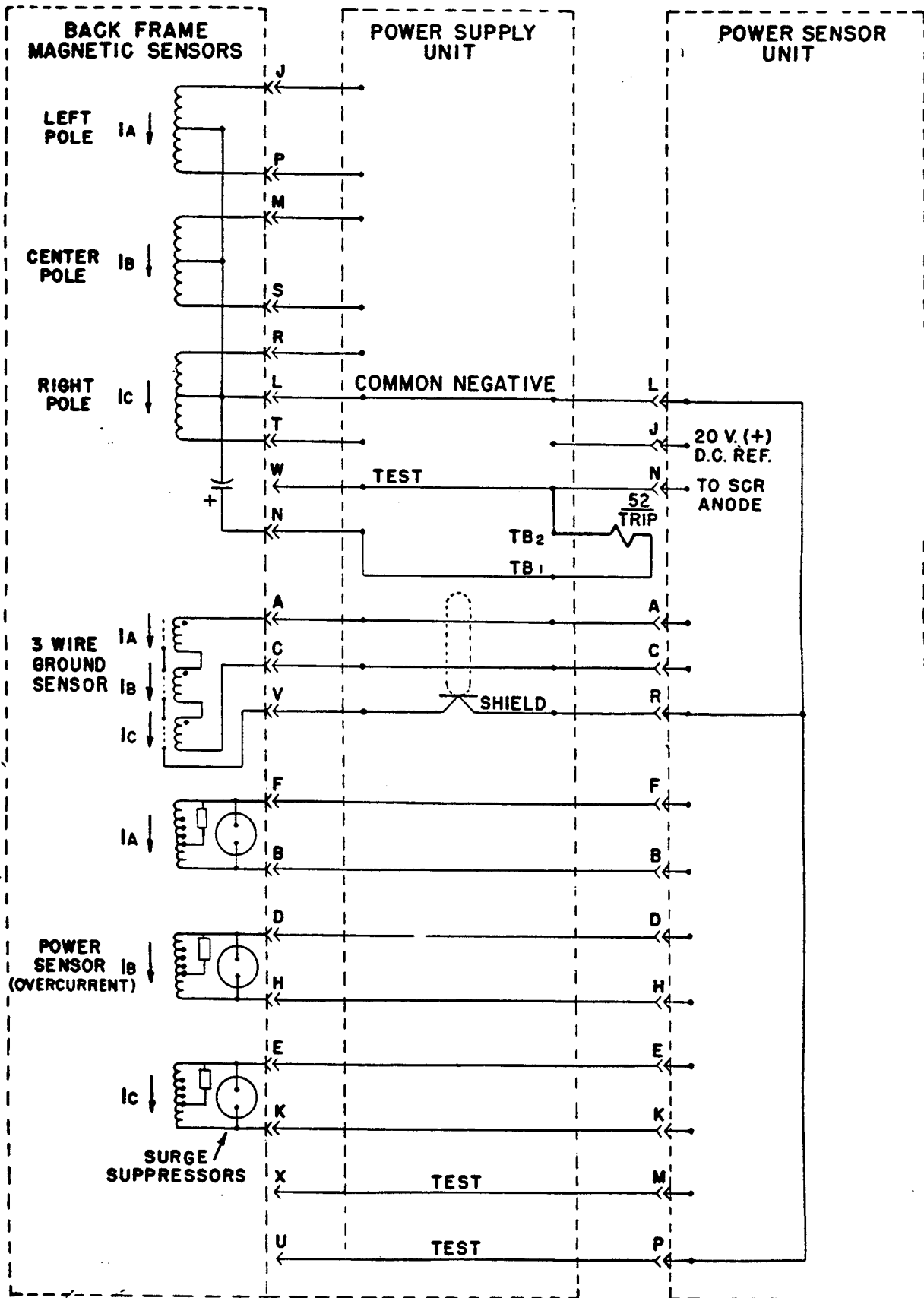

Figure 6. (133C9017-3) Power Sensor Cabling Diagram Drawing

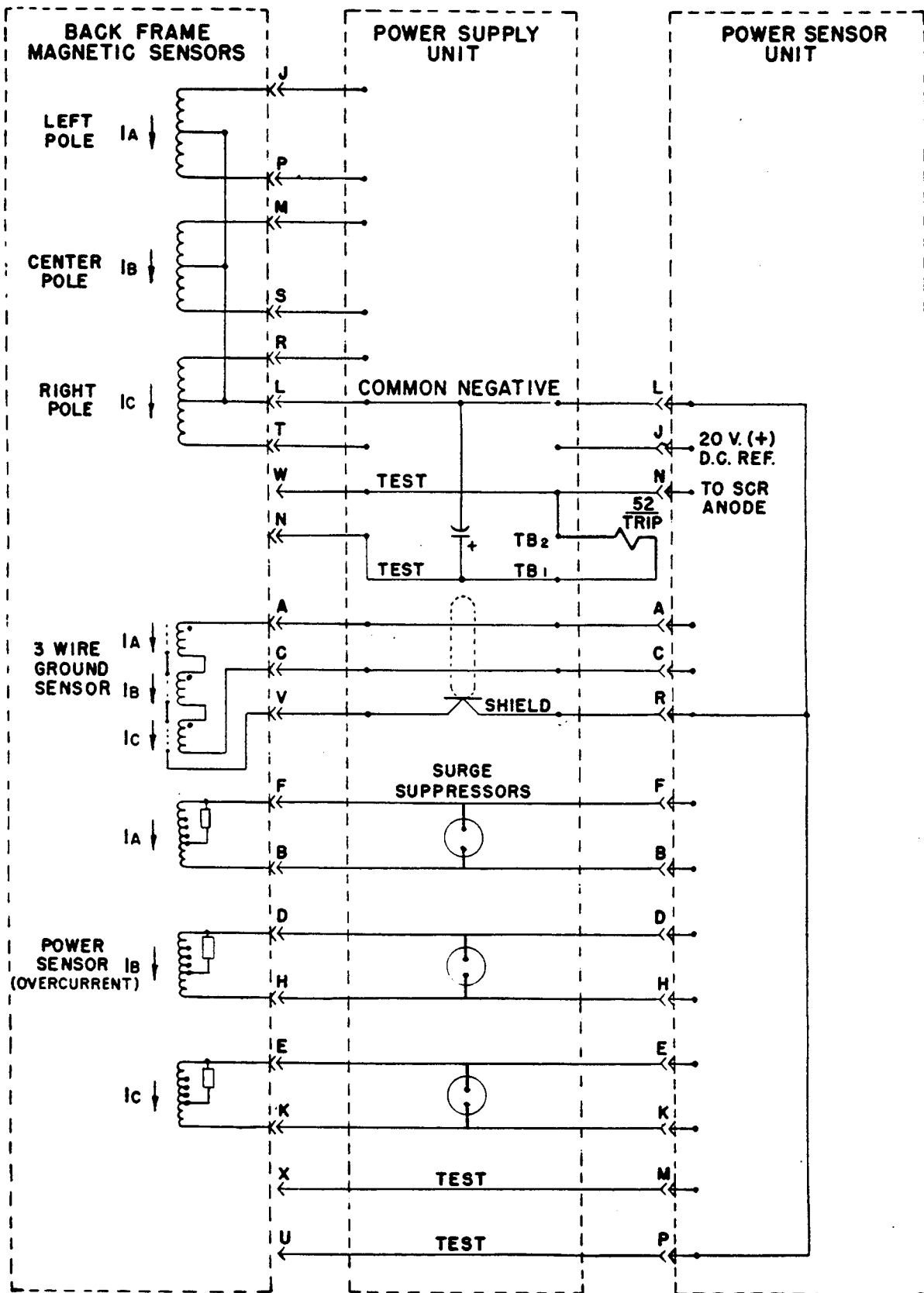
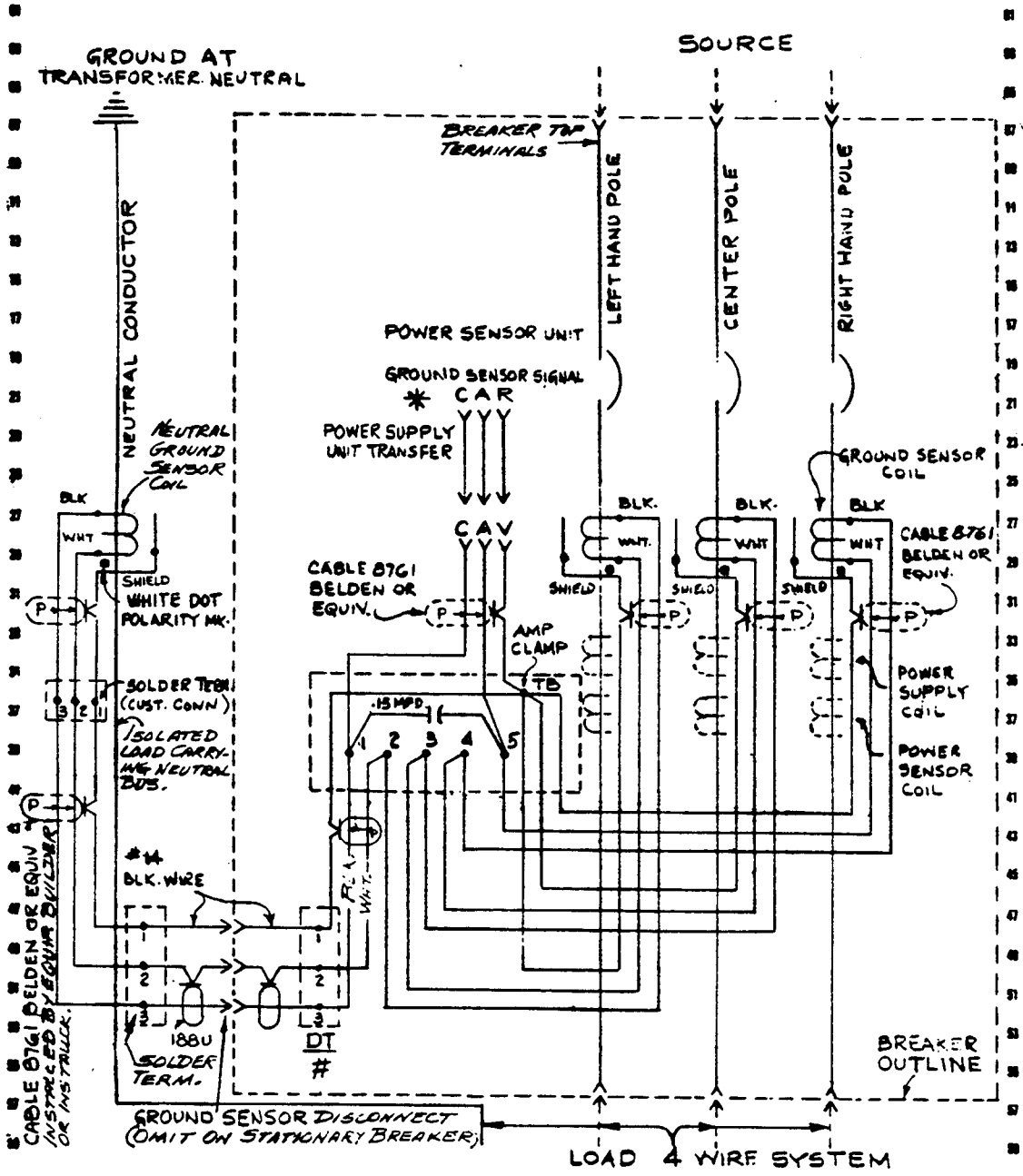

Figure 7. (133C9018-3) Power Sensor Cabling Diagram Drawing
AK-3-50/75/100



INITIAL INSTALLATION OF POWER SENSOR UNIT DISCONNECT

- * CHECK CONTINUITY A TO C
- CHECK NO CONTINUITY A OR C TO R (SHIELD)
- CHECK CONTINUITY R TO SHIELD OF NEUTRAL GROUND SENSOR COIL.

TYPICAL GROUND FAULT CONNECTIONS (BREAKER, CABLING, GROUND SENSOR DISCONNECT AND EXTERNAL GROUND SENSOR COIL)

PART OF PS-1 POWER SENSOR TRIP

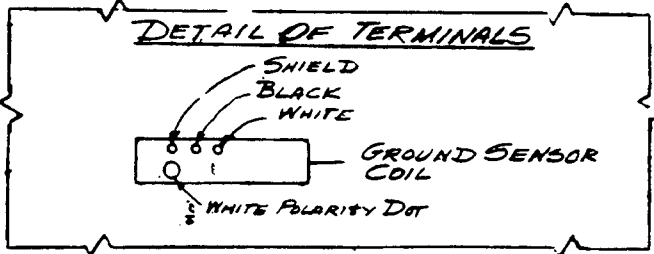

Figure 8. (138B2454-6) Ground Fault System Wiring Diagram

GENERAL ELECTRIC INSTALLATION AND SERVICE ENGINEERING OFFICES

FIELD SERVICE OFFICE CODE KEY

- Mechanical & Nuclear Service
- Electrical & Electronic Service
- Marine Service
- Transportation

FOR YOUR LASTING SATISFACTION... with the performance and availability of your General Electric equipment, GE provides this nationwide network of field service offices, serving utility, industrial, transportation and marine users. Qualified field engineers provide installation, start-up, employee training, engineering maintenance and other services, throughout the productive life of the equipment. For full information, call your nearest installation & Service Engineering office.

ALABAMA
 • † Birmingham 36306 ... 2151 Highland Ave.
 • † Mobile 36609 ... 1111 S. Baltimore Highway

ALASKA
 † Anchorage 99501 ... 115 Whitney Rd.

ARIZONA
 • † Phoenix 85013 ... 2640 N. Central Ave.
 † Tucson 85716 ... 151 S. Tucson Blvd.

ARKANSAS
 † North Little Rock 72119 ... 130 Main St.

CALIFORNIA
 • † Los Angeles 90064 ... 212 N. Vignes St.
 † Palo Alto 94303 ... 960 San Antonio Rd.
 † Sacramento 95808 ... 2407 J St.
 † San Diego 92103 ... 2540 First Ave.
 • † San Francisco 94119 ... 55 Hawthorn St.
 • † Tucson 90064 ... 3036 E. 4th St.

COLORADO
 † Denver 80206 ... 301 University Blvd.

CONNECTICUT
 • † Meriden 06450 ... 1 Prestige Dr.

FLORIDA
 † Jacksonville 32203 ... 4040 Woodcock Dr.
 † Miami 33134 ... 4100 W. Flagler St.
 • † Tampa 33609 ... 2106 S. Lois Ave.

GEORGIA
 • † Atlanta 30308 ... 1860 Peachtree Rd., NW
 † Savannah 31406 ... 5003 Paulson St.

HAWAII
 • † Honolulu 96813 ... 440 Coral St.

ILLINOIS
 • † Chicago 60690 ... 840 S. Canal St.

INDIANA
 † Evansville 47706 ... 2709 Washington Ave.
 † Fort Wayne 46807 ... 3806 S. Calhoun St.
 • † Indianapolis 46207 ... 3750 N. Meridian St.

IOWA
 † Davenport 52806 ... P. O. Box 630, 1039 State St., Bettendorf

KENTUCKY
 † Louisville 40218 ... 2300 Meadow Dr.

LOUISIANA
 • † Baton Rouge 70806 ... 8312 Florida Blvd.
 • † New Orleans 70125 ... 4747 Earhart Blvd.
 † Shreveport 71104 ... 2600 Centenary Blvd.
 † Monroe 71201 ... 1038 North 9th St.

MARYLAND
 • † Baltimore 21201 ... 1 N. Charles St.

MASSACHUSETTS
 • † Wellesley 02181 ... 1 Washington St.

MICHIGAN
 • † Detroit 48202 ... 700 Anstonette St.
 † Jackson 49201 ... 210 W. Franklin St.
 † Saginaw 48907 ... 1006 Second National Bank Bldg.

MINNESOTA
 • † Duluth 55802 ... 300 W. Superior St.
 • † Minneapolis 55416 ... 1500 Lilac Drive So.

MISSOURI
 • † Kansas City 64199 ... 911 Main St.
 † St. Louis 63101 ... 1015 Locust St.

MONTANA
 † Butte 59701 ... 103 N. Wyoming St.

NEBRASKA
 • † Omaha 68102 ... 409 S. 17th St.

NEW JERSEY
 • † Millburn 07041 ... 25 E. Willow St.

NEW YORK
 † Albany 12206 ... 15 Computer Drive, West
 † Buffalo 14205 ... 625 Delaware Ave.
 • † New York 10023 ... 641 Lexington Ave.
 † Rochester 14604 ... 89 East Ave.
 • † Syracuse 13204 ... 3532 James St.

NORTH CAROLINA
 • † Charlotte 28207 ... 141 Providence Rd.
 † Wilmington ... Reigelwood 28456 ... P. O. Box 186

OHIO
 • † Cincinnati 45206 ... 2621 Victory Pkwy.
 • † Cleveland 44104 ... 1000 Lakeside Ave.
 † Columbus 43229 ... 1110 Morse Rd.
 † Toledo 43606 ... 3125 Douglas Rd.
 † Youngstown 44507 ... 272 Indiana Ave.

OKLAHOMA
 • † Oklahoma City 73106 ... 2000 Chassee Blvd.
 † Tulsa 74105 ... P. O. Box 7646, Southside Sta.

OREGON
 † Eugene 97401 ... 1170 Pearl St.
 • † Portland 97210 ... 2829 NW 29th Ave.

PENNSYLVANIA
 • Allentown 18102 ... 1444 Hamilton St.
 • † Philadelphia 19103 ... 3 Penn Center Plaza
 † Pittsburgh 15222 ... 300 6th Avenue Bldg.

SOUTH CAROLINA
 † Columbia 29204 ... 2700 Middleburg Dr.
 † Greenville 29607 ... 41 No. Pleasantburg Dr.

TENNESSEE
 • † Chattanooga 37411 ... 5800 Bldg. Eastgate Center
 † Memphis 38130 ... 3385 Airways Blvd.

TEXAS
 • † Amarillo 79101 ... 303 Polk St.
 • † Beaumont 77704 ... 1385 Calder Ave
 • † Corpus Christi 78401 ... 205 N. Chaparral St.
 † Dallas 75222 ... 8101 Stemmons Freeway
 † El Paso 79945 ... 215 N. Shattas
 † Fort Worth 76102 ... 406 W. Seventh St.
 † Houston 77027 ... 4218 Richmond Ave.
 † San Antonio 78204 ... 434 S. Main St.

UTAH
 † Salt Lake City 84111 ... 431 S. Third East St.

VIRGINIA
 • † Newport News 23601 ... 311 Main St.
 † Richmond 23230 ... 1508 Willow Lawn Dr.
 † Roanoke 24015 ... 2018 Colonial Ave.

WASHINGTON
 • † Seattle 98188 ... 112 Andover Park East, Tukwila
 † Spokane 99202 ... E. 1806 Trent Ave.

WEST VIRGINIA
 • † Charleston 25328 ... 306 MacCorkle Ave., SE

WISCONSIN
 • † Appleton 54911 ... 3003 West College Dr.
 † Milwaukee 53202 ... 615 E. Michigan St.

GENERAL ELECTRIC SERVICE SHOPS

WHEN YOU NEED SERVICE... These GE Service Shops will repair, recondition, and rebuild your electric apparatus. The facilities are available day and night, seven days a week, for work in the shops or on your premises.

Latest factory methods and genuine GE renewal parts are used to maintain performance of your equipment. For full information about these services, contact your nearest service shop or sales office.

ALABAMA
 • Birmingham 35211 ... 1500 Mine Ave., S. W.
 • Mobile 36609 ... 731 Lakeside Dr.

ARIZONA
 • (Phoenix) Glendale 85019 ... 4911 W. Colter St.
 • Phoenix 85019 ... 3801 E. LaPalma Ave.
 • Tucson 85713 ... 2942 So. Palo Verde Ave.

CALIFORNIA
 • Los Angeles 90301 ... 6800 Stanford Ave.
 • (Los Angeles) Anaheim 92805
 • (Los Angeles) Inglewood 90301
 • Sacramento 95814 ... 228 W. Florence Ave.
 • (San Francisco) Oakland 94608 ... 99 North 17th St.
 • ... 1860 34th St.

COLORADO
 • Denver 80206 ... 3363 Larimer St.

CONNECTICUT
 • (Southington) Plainville 06479 ... 370 Arwater St.

FLORIDA
 • Jacksonville 32203 ... 2020 W. Beaver St.
 • (Miami) Hialeah 33010 ... 1062 East 29th St.
 • Tampa 33601 ... 19th & Grant Sts.

GEORGIA
 • (Atlanta) Chamblee 30341 ... 5035 Peachtree Industrial Blvd.
 • Atlanta ... 2379 John Glenn Dr.

ILLINOIS
 • Chicago 60690 ... 6048 S. Nottingham Ave.

INDIANA
 • Evansville 47711 ... 401 N. Congress Ave.
 • Ft. Wayne 46803 ... 1731 Edsall Ave.
 • Hammond 46330 ... 1136 164th Place
 • Indianapolis 46223 ... 1740 W. Vermont St.

IOWA
 • Davenport Bettendorf 52723 ... 1028 State St.

KENTUCKY
 • Louisville 40208 ... 3900 Critchfield Drive

LOUISIANA
 • Baton Rouge 70814 ... 10955 North Dual St.
 • New Orleans 70114 ... 1115 DeArmas St.

MARYLAND
 • Baltimore 21230 ... 920 E. Fort Ave.

MASSACHUSETTS
 • (Boston) Medford 02155 ... 3940 Mystic Valley Pkwy.

MICHIGAN
 • (Detroit) Riverview ... 18075 Krause Ave.
 • Flint 48505 ... 1506 E. Carpenter Rd.

MINNESOTA
 • Duluth 55807 ... 50th Ave. W. & St. Louis Bay
 • Minneapolis 55430 ... 2025 49th Ave., N.

MISSOURI
 • Kansas City 64120 ... 3525 Gardner Ave.
 • St. Louis 63110 ... 1115 East Rd.

NEW JERSEY
 • New Brunswick 08902 ... 3 Lawrence St.

NEW MEXICO
 • Albuquerque 87109 ... 4420 McLeod Rd. NE

NEW YORK
 • Albany 12205 ... 1097 Central Ave.
 • (Buffalo) Tonawanda 14150 ... 175 Millens Rd.
 • (Long Island) Old Bethpage 11804 ... 83 Bethpage-Sweet Hollow Rd.
 • (New York City) North Bergen, N. J. 07012 ... 6001 Tonawalla Ave.
 • (New York City) Clifton, N. J. 07012 ... 8 Brighton Rd.
 • Schenectady 12306 ... 1 River Rd.
 • Syracuse 13206 ... 1815 E. Shawana Blvd.

NORTH CAROLINA
 • Charlotte 28208 ... 2326 Third Rd.

OHIO
 • Akron (Canton) 44720 ... 7800 Whipple Ave. N. W.
 • Cincinnati 45202 ... 444 West 3rd St.
 • Cleveland 44125 ... 4477 East 49th St.
 • Columbus 43229 ... 6980 Bentley Rd.
 • Toledo 43606 ... 406 Dunbar Ave.
 • Youngstown 44507 ... 272 E. Indiana Ave.

OKLAHOMA
 • Tulsa 74145 ... 5230 S. 100th East Ave.

OREGON
 • Eugene 97402 ... 570 Wilson St.
 • Portland 97210 ... 2727 NW 29th Ave.

PENNSYLVANIA
 • Allentown 18103 ... 668 E. Highland St.
 • (Delaware Valley) Cherry Hill, N. J. 08034 ... 1790 E. Marlton Pike
 • Johnstown 15802 ... 841 Oak St.
 • Philadelphia 19124 ... 1040 East Erie Ave.
 • (Pittsburgh) West Mifflin 15122 ... 4930 Buttermilk Hollow Rd.
 • York 17403 ... 54 N. Harrison St.

SOUTH CAROLINA
 • (Charleston) No. Charleston 29401 ... 2490 Debonair St.

TENNESSEE
 • Knoxville 37914 ... 2621 Governor John Sevier Hwy.
 • Memphis 38107 ... 708 North Main St.

TEXAS
 • Beaumont 77705 ... 1480 W. Cardinal Dr.
 • Corpus Christi 78401 ... 115 Waco St.
 • Dallas 75235 ... 3208 Manor Way
 • Houston 77036 ... 5534 Harvey Wilson Dr.
 • Houston 77036 ... 6916 Harris Dr.
 • Midland 79701 ... 704 S. Johnston St.

UTAH
 • Salt Lake City 84110 ... 301 S. 7th West St.

VIRGINIA
 • Richmond 23234 ... 1403 Ingram Ave.
 • Roanoke 24013 ... 1004 River Ave., SE

WASHINGTON
 • Seattle 98134 ... 3422 First Ave., South
 • Spokane 99211 ... E. 4323 Mission St.

WEST VIRGINIA
 • Charleston 25328 ... 306 MacCorkle Ave., SE

WISCONSIN
 • Appleton 54910 ... 1719 Racine St.
 • Milwaukee 53207 ... 236 W. Oklahoma Ave.

• Electrical/Mechanical Service Shop • Instrumentation Shop • Special Manufacturing Shop



MicroVersaTrip® RMS-9 Programmer

For Circuit Breakers
150–4000 Amps; 240,
480 and 600 Vac

INTRODUCTION

MicroVersaTrip® RMS-9 programmer is the General Electric state-of-the-art solid state overcurrent protection programmer for industrial circuit breakers. The MicroVersaTrip® RMS-9 programmer includes a digital microprocessor for direct rms sensing of sinusoidal or harmonic power distribution currents.

The MicroVersaTrip® RMS-9 programmer is factory installed in the frame. Breaker ampere ratings may be upgraded in the field by changing rating plug on the front of the MicroVersaTrip® RMS-9 programmer.

The current sensors and flux shifters used for the MicroVersaTrip® RMS-9 programmers are identical to the ones used for the MicroVersaTrip® programmer.

The MicroVersaTrip® RMS-9 programmer is provided with circuit breakers with the following frame designations:

“J” Molded Case Circuit Breakers: TJH,TJL

“K” Molded Case Circuit Breakers: TKH,TKL

Power Break Circuit Breakers: TP___SS,
THP___SS,
TC___SS,
THC___SS,

AK/AKR Circuit Breakers
and conversion kits: AKR-30, AKR-30S
AKRU-30, AKR-30H,
AKR-50, AKRT-50
AKR-75, AKR-100,
AK-25, AKS-50
AK-75, AK-100

TRIPPING FUNCTIONS

General Description

1. Current Setting—standard
2. Long Time Delay—standard
3. Long Time Pickup Light—standard (Mounted in Rating Plug)
4. Short Time Pickup—optional (Cat. No. Suffix “S”)

5. Short Time Delay—optional (Cat. No. Suffix “S”)
6. Instantaneous Pickup—optional in AKR breakers, standard for other breakers, Standard Instantaneous (Cat. No. Suffix “I”), Adjustable High Range Instantaneous (Cat. No. Suffix “H”)
7. Ground Fault Pickup—optional (Cat. No. Suffix “G”)
8. Ground Fault Delay—optional (Cat. No. Suffix “G”)
9. Triple Selective Trip with Fixed High Range Instantaneous—optional in AKR-30S Breakers (Cat. No. Suffix “K”)
10. Fault Trip Targets—optional Overload and Short Circuit (Cat. No. Suffix “T1”) Overload, Short Circuit and Ground Fault (Cat. No. Suffix “T2”)
11. Zone Selective Interlock—optional, Ground Fault Only (Cat. No. Suffix “Z1”), Ground Fault and Short Time (Cat. No. Suffix “Z2”)
12. Switchable OFF Instantaneous/Ground Fault—optional for AK/AKR only. Pickup functions can be deleted by turning switch to OFF position (Cat. No. Suffix X). Breakers with this programmer option are not UL Listed.

RATING PLUG

The MicroVersaTrip® RMS-9 trip units are designed for use with UL listed field interchangeable rating plugs. These rating plugs serve the function of changing the per unit (1 X) rating of a breaker, or in other words, changing the ampere rating. Several rating plugs exist for a particular sensor. The maximum value of a rating plug is equal to the sensor rating(S). Each rating plug is keyed for a particular sensor. An Epic or MicroVersaTrip® RMS-9 circuit breaker frame, when shipped from the factory, is configured to accept only the specific rating plugs keyed to that particular sensor.

The long time timing light and test jack are housed within the rating plug.

DETAILED DESCRIPTION

1. CURRENT SETTING

Current Setting "C", is the current value the breaker will carry indefinitely without tripping. The value of the current is determined by the product of current setting and the ampere rating on the rating plug, "X".

Settings are .5X, .6X, .7X, .8X, .85X, .9X, .95X and 1.0X for J/K and Power Break® circuit breakers. For AKR low voltage circuit breakers, settings are .5X, .6X, 7X, .8X, .9X, .95X, 1.0X and 1.1X.

2. LONG TIME PICKUP AND DELAY

The Long Time pickup is fixed at 110% of the current setting for J/K and Power Break circuit breakers and at 100% of current setting for AKR low voltage circuit breakers.

The Long Time delay trip bands provide the function of withstanding temporary overloads such as motor starting, welding or other overcurrent conditions without interrupting service.

The purpose of the time delay bands is to provide further degrees of coordination and selectivity within a system. The delay bands provide increasing times to trip at any fixed overload current. The bands are marked as follows:

Continuous Current Ratings 150–4000 Amps	Typical Time Delay at 600% of Device Setting (nominal time delay)
Band 1	3 seconds
Band 2	6 seconds
Band 3	12 seconds
Band 4	25 seconds

3. LONG TIME PICKUP LIGHT

Whenever the current reaches 105% of the current setting for J/K and Power Break circuit breakers, and 95% for AKR low voltage power circuit breakers, the Long Time pickup LED will flash to indicate the approach of the full load condition. When the breaker load current is over the pickup threshold, the LED will be on continuously (110% of current setting for J/K and Power Break, and 100% for AKR breakers.)

4. SHORT TIME PICKUP

The primary function of the Short Time pickup is to allow the breaker to carry a high level of current for a short period of time. This feature provides a further degree of selectivity within a system.

The Short Time pickup settings are the following multiplies of current setting:

1.5C, 2C, 2.5C, 3C, 4C, 5C, 7C and 9C

5. SHORT TIME DELAY

The adjustable Short Time delay provides further coordination between "upstream" and "downstream" breakers which have the same short time pickup setting.

The I²t IN/OUT section provides further selectivity by placing the I²t section of the short time region in or out. When the switch selection is OUT, the constant time delay bands dictate the short time trip characteristics. When the switch is in the IN position, depending on the magnitude of the fault current, the trip time will be on the I²t section of the curve or the constant time delay section if the fault magnitude is high enough.

These six selections are available for the short time delay function (delay shown at 600% of current settings with pickup set at 5C or lower

1. I²t IN minimum delay, .5 seconds on I²t slope
2. I²t IN intermediate delay, .5 seconds on I²t slope
3. I²t IN maximum delay, .5 seconds on I²t slope
4. I²t OUT maximum delay, .42 seconds
5. I²t OUT intermediate delay, .26 seconds
6. I²t OUT minimum delay, .13 seconds

9. INSTANTANEOUS PICKUP

The instantaneous setting provides immediate (no intentional time delay) interruption of severe overloads, thereby minimizing damage to system equipment. There are three variations possible:

a. NO INSTANTANEOUS

This is available in AKR breakers only.

b. ADJUSTABLE INSTANTANEOUS

The following variations are possible for the different MicroVersaTrip® RMS-9 units. There are several combinations possible depending on the rating of the breaker and whether short time has been selected or not. The combinations are:

- 1.5X, 2X, 3X, 5X, 7X, 9X, 10X, 13X, 15X
- 1.5X, 2X, 3X, 5X, 7X, 9X, 10X, 13X
- 1.5X, 2X, 3X, 5X, 7X, 9X, 10X
- 1.5X, 2X, 3X, 5X, 7X, 9X
- 1.5X, 2X, 3X, 5X, 7X, 9X, 10X, 13X, 15X, OFF (AKR Only)
- 1.5X, 2X, 3X, 5X, 7X, 9X, 10X, OFF (AKR Only)
- 1.5X, 2X, 3X, 5X, 7X, 9X, OFF (AKR Only)

c. HIGH RANGE INSTANTANEOUS

High range instantaneous provides protection and coordination at levels up to the full short-time rating of the circuit breaker. High range instantaneous is adjustable from 40% to 100% of the short time rating in four steps of 20% each. Available on Power Break® and AKR breakers only.

10. GROUND FAULT PICKUP

Settings are adjustable with no setting exceeding 1200 Amps to comply with National Electrical Code, Section 230-95.

These settings are the following multiples of Sensor Ampere Rating (S):

- 150-2000 Amps—.2S, .25S, .3S, .35S, .4S, .45S, .5S, .6S
- 2500A & 3000 Amps—.2S, .22S, .24S, .26S, .28, .30S, .34S, .37S
- 4000 Amps—.2S, .22S, .24S, .26S, .28S, .3S

11. GROUND FAULT DELAY

The adjustable ground fault delay provides further coordination between “upstream” and “downstream” breakers which have the same ground fault pickup setting.

The I²t IN/OUT section provides further selectivity by placing the I²t section of the ground fault region in or out. When the switch selection is OUT, the constant ground fault delay bands dictate the ground fault trip characteristics. When the switch is in the IN position, depending on the magnitude of the ground fault current, the ground fault trip will be on the I²t section of the curve or the constant ground fault delay section if the fault magnitude is high enough.

These six selections are available for the ground fault delay function. (nominal delay shown at 200% of pickup setting):

1. I²t IN minimum delay, .5 seconds on I²t slope
2. I²t IN intermediate delay, .5 seconds on I²t slope
3. I²t IN maximum delay, .5 seconds on I²t slope
4. I²t OUT maximum delay, .42 seconds
5. I²t OUT intermediate delay, .26 seconds
6. I²t OUT minimum delay, .13 seconds

12. FAULT TRIP TARGETS

The mechanical pop-out fault targets identify the type of overcurrent fault (overload, short circuit or ground fault) responsible for tripping the breaker. The target has to be reset manually by pressing it back into the programmer.

13. ZONE SELECTIVE INTERLOCK

The Zone Selective Interlock system allows the breaker sensing the fault to trip immediately. Zone Selective Interlock is available in two versions: a) Ground Fault Only “Z1” or b) Short Time and Ground Fault “Z2”. One or more Zone Selective Interlock Modules, Cat. No. TIM1(120Vac input) or TIM2(125Vdc input) must be used with the Zone Interlock option. Refer to Instructions GEK-64467A for connection details.

Whenever the downstream breaker goes into Ground Fault Pickup for “Z1” (and/or Short Time Pickup for “Z2”) and the fault current magnitude is in the region where the constant time delay bands are in effect, a signal is sent to the upstream breaker, through the zone interlock module.

When the Zone Selective Interlock signal is received, the upstream breaker’s delay band is changed from minimum to the one selected by the switch setting for Z1. For a breaker with the Z2 option, both ground fault and short time bands are changed from the minimum to the switch setting.

Note that a programmer with the zone interlock option will time out on the minimum delay band for Ground Fault for Z1 (and Short Time for Z2) in the absence of a signal from a downstream interlock module. The switch settings are relevant only when a Zone Input signal is received.

MOUNTING NEUTRAL CURRENT SENSORS (required on a 4-wire system if the programmer has the ground fault protection system)

If the load circuit does not include a neutral (for example: 3-phase, 3-wire), the neutral sensor terminals on the circuit breaker should be left open and neutral sensor not used. (Do not “short” terminals)

When a neutral is included in the load circuit, neutral sensor line and load markings must be respected when making bus or cable connections.

The polarity of connecting wires from secondary of neutral sensor to circuit breaker must also be respected: white to white, black to black.

The neutral sensor can only be used with a breaker whose sensor rating(S) matches the neutral sensor ampere rating or tap setting.

WIRING

Connect wiring from sensor to breaker black to black and white to white using twisted pair #14 AWG minimum, Belden 8640,61 or 8470,71 or equal.

TESTING MICROVERSATRIP® RMS-9 PROGRAMMER

Cat. No. TVRMS is a portable, hand-held, battery powered, test kit providing RMS-9 programmer self-tests and functional trip/no trip tests. Interface is via a plug on the front of the programmer and tests can be conducted with breaker in service. Kit uses six rechargeable NICAD or standard alkaline “D” cells supplied by customer. Kit can also be powered by 120-volts ac source. Testing of a MicroVersa-Trip® RMS-9 equipped circuit breaker may also be accomplished using primary current from a high current, low voltage test set.

When high current testing a breaker with ground fault option, one of several methods must be employed to insure that a ground fault trip does not preempt a long-time or short-time trip:

A. Single-pole testing

- (1) Plug TVRMS test kit into programmer and follow menu driven instructions for high current testing (this will temporarily defeat the ground fault function). Or,
- (2) For breakers rated 2000A maximum - use a value of test current less than 90 percent of the ground fault pickup setting, but greater than 110 percent of the long-time or short-time pickup. (In most cases this will require a low current setting or short-time pickup, and a high ground fault pickup setting.)

B. Test with two-poles in series

Connect high current source (leads L1 and L2) to line side of breaker and jumper load terminals as shown in Figure 1.

- C.** Note that test kit Cat. No. TVRMS can always be used when using primary injection (high current test set) to temporarily defeat the ground fault function.

each other in a loop circuit. With this arrangement, the circuit is not responsive to normal neutral loading, but is responsive to ground fault current regardless of its return path to the source supplying ground fault current. Each breaker should have an auxiliary "A" contact connected as shown. The auxiliary contact "A" condition is similar to the breaker. When the breaker is open, "A" is open. When the breaker is closed, "A" is closed.

One breaker must always be open so its neutral sensors will be disconnected from its associated breaker to provide the driving force to assure that the current flows around the sensor loop circuit.

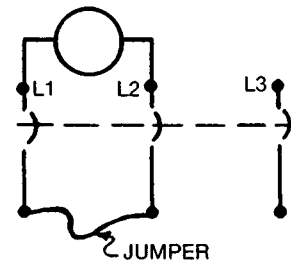

Figure 1

CAUTION:

When high current testing a breaker with ground fault option, ground fault defeat cable Cat. No. TVTGD9 must **NOT** be used. Only MicroVersa Trip® RMS-9 test kit Cat. No. TVRMS may be used to temporarily defeat the ground fault function. Programmer damage may result if these cautions are not followed.

GROUND FAULT PROTECTION SCHEMES

MicroVersaTrip® RMS-9 programmers used on AKR Low Voltage Power Circuit Breakers, Power Break Insulated Case Circuit Breakers, and Molded Case Circuit Breakers are self-powered. The integral ground fault function (suffix "G") provided vectorially sums the phase currents and neutral current, if present, as shown in Figure 1. In the absence of ground fault currents the vector sum of the phase and neutral currents, I_G , is zero. With a ground fault, the vector sum, I_G corresponds to the ground fault current.

MULTI-SOURCE SYSTEMS

Multi-source systems with grounded neutral inter-ties such as secondary selective and spot networks require special ground fault circuitry.

In the circuit shown in Figure 2, the neutral sensor secondary windings, in addition to being connected to their respective breaker, are interconnected with

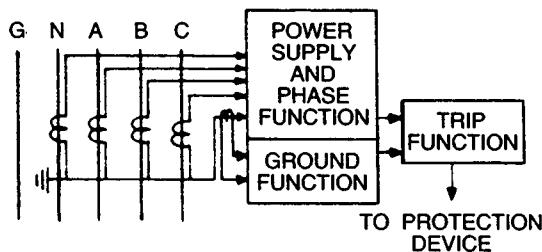

Figure 2

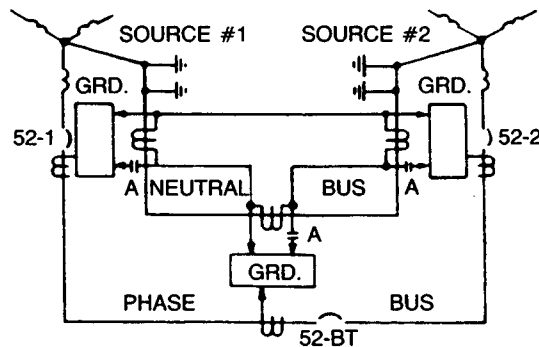

Figure 3

© 1987 GE Company

These instructions do not purport to cover all details or variations in equipment nor to provide for every possible contingency to be met in connection with installation operation or maintenance. Should further information be desired or should particular problems arise which are not covered sufficiently for the purchaser's purposes, the matter should be referred to GE Company.

For further information, call or write your local GE sales office, or:
 GE
 41 Woodford Avenue
 Plainville, Connecticut 06062

Outside the US and Canada, write:
 GE Export Operation
 411 Theodore Fremd Avenue
 Rye, New York 10580 USA





MicroVersaTrip[®] RMS-9 and Epic MicroVersaTrip[™] Rating Plug

For J/K, Power Break[®] and AKR Circuit Breaker Frames

FUNCTION

The MicroVersaTrip[®] RMS-9 and Epic MicroVersaTrip[™] trip units are designed for use with UL listed field interchangeable rating plugs. These rating plugs serve the function of changing the per unit (1X) continuous current rating of a breaker. A circuit breaker frame equipped with a suitable rating plug will have a long time trip value equal to the ampere rating marked on the rating plug.

For example, a breaker frame with a 1200 amp sensor and an 800A rating plug will have an 800 amp continuous current (long-time) rating.

Several rating plugs exist for a particular sensor rating and each rating plug is keyed for a particular sensor rating.

Table 1 outlines all the available rating plugs for the AKR and Power Break[®] families and Table 2 lists all available plugs for the J and K frame breakers.

FRONT LABEL (FIGURE 1)

The front plate label shown in Figure 1 is visible when the rating plug is installed. The items displayed are as follows:

Sensor Rating (S)	The ampere rating of the corresponding breaker frame
Rating Plug Amps (X)	The rating plug continuous current rating in amps
Pickup	The long-time pickup LED lights (LED) will begin to flash when the breaker approaches 95% of long-time pickup. When the breaker load reaches 100% of the long time pickup, the LED will remain on continuously.

NOTE: the Pickup light will not come on during a test run with the Test Kit.

Test The test jack receptacle is used with Cat. No. TVRMS test kit for overcurrent and ground fault functional testing.

UL LABEL

This label is mounted on the side of the rating plug and is not visible with the rating plug installed. The label lists the breaker frames that will accept that particular rating plug.

INSTALLATION

Before installing a rating plug into a MicroVersaTrip[®] RMS-9 or Epic MicroVersaTrip[™] trip unit, inspect for physical damage.

Step 1: Verify that the rating plug catalog number matches the desired continuous current rating (X) and the sensor rating (S) shown on the breaker frame.

Step 2: Grasp the rating plug by the thumb and forefinger and push it into the programmer. Proper engagement will be verified by a "click".

DO NOT ATTEMPT TO PUSH THE RATING PLUG INTO THE PROGRAMMER IF RESISTANCE IS FELT. YOU MAY HAVE THE WRONG RATING PLUG FOR THE FRAME/SENSOR RATING. STOP IMMEDIATELY AND VERIFY THAT THE BREAKER SENSOR "S" AND THE RATING PLUG "S" ARE THE SAME VALUE.

REMOVAL

To remove rating plug, grasp the two ends of the rating plug tabs with two small (1/8" maximum width blade) flat head screwdrivers (see Figures 1 and 2) and gently pry out.

NOTE: PROTECTION TO THE BREAKER IS MAINTAINED AT A MUCH LOWER RATING (25% OF SENSOR RATING) WHEN THE RATING PLUG IS PULLED OUT. If the breaker is carrying more than 25% of the sensor rating load current when the rating plug is removed, the breaker may trip.

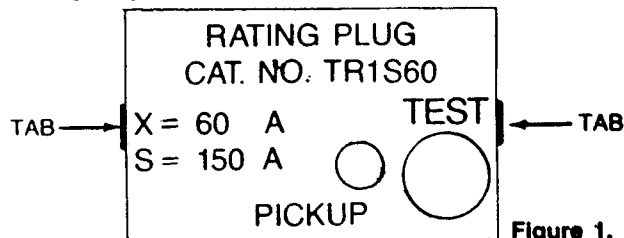

Figure 1.

Table 1
Available Rating Plugs for GE Type AKR
and Power Break® Frames

RATING PLUG CAT. NO.	SENSOR RATING (AMPERES)	RATING PLUG RATING (AMPERES)	BREAKER FRAMES
TR1S60,		60	
TR1S80,		80	
TR1S100,	150	100	AKR30S,
TR1S125,		125	AKR30H
TR1S150		150	
TR2S100,		100	
TR2S150,	200	150	TP82
TR2S200		200	
TR4S150,		150	
TR4S200,		200	
TR4S225,	400	225	TP84,
TR4S250,		250	AKR30H,
TR4S300,		300	AKR30S
TR4S400		400	
TR8S300,		300	
TR8S400,		400	TP88,
TR8S500,	800	500	AKR30S,
TR8S600,		600	AKR30H,
TR8S700,		700	AKR50,
TR8S800		800	AKR50H
TR10S400,		400	
TR10S600,	1000	600	TP1610,
TR10S800,		800	TP2510
TR10S1000		1000	
TR16S600,		600	
TR16S800,		800	
TR16S1000,	1600	1000	AKR50,
TR16S1200,		1200	AKR50H,
TR16S1600		1600	TP1616
TR20S750,		750	
TR20S800,		800	
TR20S1000,	2000	1000	TP2020,
TR20S1200,		1200	TP2520,
TR20S1600,		1600	AKRT50H
TR20S2000		2000	
TR25S1600,		1600	
TR25S2000,	2500	2000	TP2525
TR25S2500		2500	
TR30S2000,		2000	
TR30S2500,	3000	2500	TP3030
TR30S3000		3000	
TR32S1200,		1200	
TR32S1600,	3200	1600	AKR75
TR32S2400,		2400	
TR32S3200		3200	
TR40S1600,		1600	
TR40S2000,		2000	
TR40S2500,	4000	2500	AKR100
TR40S3000,		3000	TP4040
TR40S4000		4000	

NOTE: TP (stationary) frames shown are also available as TC (draw-out), THP (Hi-Break), and THC (Hi-Break® draw-out) i.e., rating plug TR2S100 is suitable for TP82, THP82, TC82, and THC82 frames.

Table 2
Available Rating Plugs for
J and K Frames

RATING PLUG CAT. NO.	SENSOR RATING (AMPERES)	RATING PLUG RATING (AMPERES)	BREAKER FRAMES
TR1S60J,		60	
TR1S80J,		80	
TR1S100J,	150	100	TJH1S,SS,
TR1S125J,		125	TJL1S,SS
TR1S150J		150	
TR3S150J,		150	
TR3S200J,		200	
TR3S225J,	300	225	TJH3S,SS,
TR3S250J,		250	TJL3S,SS
TR3S300J		300	
TR4S150J,		150	
TR4S200J,		200	
TR4S225J,	400	225	TJH4S,SS,
TR4S250J,		250	TJL4S,SS
TR4S300J,		300	
TR4S400J		400	
TR6S300J,		300	
TR6S400J,	600	400	TJH6S,SS,
TR6S450J,		450	TJL6S,SS
TR6S500J,		500	
TR6S600J		600	
TR8S300K,		300	
TR8S400K,		400	
TR8S500K,	800	500	TKH8S,SS,
TR8S600K,		600	TKL8S,SS
TR8S700K,		700	
TR8S800K		800	
TR12S600K,		600	
TR12S800K,	1200	800	TKH12S,SS,
TR12S1000K,		1000	TKL12S,SS
TR12S1200K		1200	

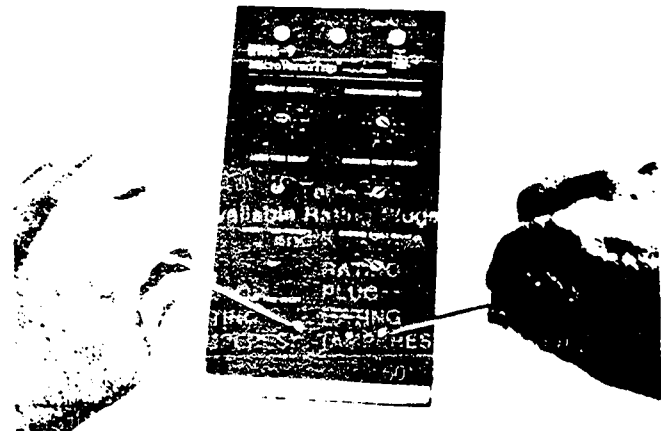

Figure 2.

© 1987 GE Company

These instructions do not purport to cover all details or variations in equipment nor to provide for every possible contingency to be met in connection with installation operation or maintenance. Should further information be desired or should particular problems arise which are not covered sufficiently for the purchaser's purposes, the matter should be referred to GE.

For further information, call or write your local GE sales office, or:
 GE Construction Equipment
 41 Woodford Avenue
 Plainville, Connecticut 06062

Outside the US and Canada, write:
 GE Construction Equipment Export Operation
 411 Theodore Fremd Avenue
 Rye, New York 10593 USA





INSTRUCTIONS

GEK-7309B
Supersedes GEK-7309A

**TEST INSTRUCTIONS FOR INSTALLATION
OR SERVICE OF**

POWER SENSOR* TRIP DEVICE

Used on AK Type Low Voltage

Power Circuit Breaker

* Registered Trademark of General Electric Co.

SWITCHGEAR PRODUCTS DEPARTMENT

GENERAL  ELECTRIC

PHILADELPHIA, PA.

CONTENTS

OBJECTIVE 3

 A. Directed toward GE I & SE, GE Service Shops, OEMs and Contract Testers.

 B. To be used as an aid in installing AK Breakers equipped with Power Sensors.

 C. To be used by them as an aid in locating the problem area when a particular breaker is suspected of improper operation.

GENERAL INFORMATION 3

TEXT 3

 A. Inspection 3

 B. On Site Power Sensor System Check 4

 C. Servicing of AK Power Sensor Breakers 8

TABLES AND CHARTS 9

QUICK - CHECK LIST 9

These instructions do not purport to cover all details or variations in equipment nor to provide for every possible contingency to be met in connection with installation, operation or maintenance. Should further information be desired or should particular problems arise which are not covered sufficiently for the purchaser's purposes, the matter should be referred to the General Electric Company.

POWER SENSOR* TRIP DEVICE

Used on AK Type Low Voltage

Power Circuit Breaker

OBJECTIVES

This instruction book is intended to serve as a supplement to the Maintenance Manuals for Low Voltage Power Circuit Breakers, and the Instructions for the Power Sensor Test Set, GEK-7301, used to check the Power Sensor trip device. It is meant to be used by GE I&SE, GE service shop, OEM, and contract tester personnel as an aid in installing AK type breakers equipped with Power Sensors, and as an aid in locating the problem area when a particular breaker is being serviced.

GENERAL INFORMATION

Before attempting any checks or adjustments, the tester must consult the maintenance manuals for the breaker to familiarize himself with the operating details of the specific breaker involved and the Power Sensor overcurrent trip device. He should disconnect the breaker from the primary power bus. Prior to checking the trip device the breaker contacts should be inspected and the mechanism and trip latch should be checked for proper functioning to verify that the breaker can suitably carry the required current. The trip shaft should be free of high friction loads. The trip latch should be checked for proper trip latch engagement and torque.

The Power Sensor trip device employs a peak reading circuit and responds to the magnitude of current in the primary phase carrying the largest current. Therefore, a non-sinusoidal current may result in what appears to be an erroneous operation of the Power Sensor system if RMS meters are used to measure the non-sinusoidal signal and the trip device responds to the peak of the signal. The peak and the RMS value of non-sinusoidal signals are not related as they are for perfect sine waves.

In high current, low voltage test circuits one of the major causes of waveform distortion is the non-linear breaker impedance. To maintain a reasonably sinusoidal current waveshape, air core reactance equal to approximately 20 microhenries should be inserted in the test circuit in series with the breaker for AK-25, 75 and 100 breakers. (No reactance is needed for AK-50 breakers unless it is rated 200-600A.)

This reactance is not needed when operating from the power system because the current is produced by a source with sufficient voltage to maintain a sinusoidal current waveform. The

output current of a high current-low voltage test set which uses a variable voltage transformer will follow the primary voltage. The current may not be sinusoidal, when the Power Sensor trip device is its load, due to the reduced voltage at the zero crossing of the current waveform. Air core reactance shifts the phase angle between the voltage and current so that at current zero the voltage will be large enough to maintain the rate of change of current needed for a sinusoidal current waveform.

Some problems may occur while testing logic units removed from breakers stored in high humidity areas. The test results may become erratic and not agree with published curves and tolerances. This can be due to a high moisture content on the surface of the logic unit's circuit boards in de-energized equipment.

This test problem has been solved by removing the logic units to a warm dry area for about an hour prior to testing. Once the breaker is carrying current, the normal elevated temperature within its compartment is enough to eliminate the effects of this high humidity environment.

Additional information that should be available during test includes:

1. Drawings #133C9017, #133C9018 and #138B2454 on pp. 11, 12 and 13.
2. GEK-7301 - Power Sensor Test Set Instructions.
3. GEK-7303 - Breaker Maintenance Manual (AK-3-50/75/100)
4. GEK-7310 - Breaker Maintenance Manual (AK-5-50)
5. GEI-50299 - Breaker Maintenance Manual (AK-25).
6. GEZ-4431 - Packet of Time Current Curves.

INSPECTION

Check the following items against the specified settings for the particular breaker application when they apply.

1. The sensor CT taps should be set at the correct current rating on all three phases. These taps must be secure. The Power Supply rating disc should also be set to the correct current rating. (See Figure 1 and Figure 3).

2. The tap selector knobs on the Power Sensor unit should be set to the correct pickup and time delay settings for the application intended. These knobs must be secure. (Figure 2)
3. The magnetic trip device must be connected to the terminal block on the power supply. (Figure 3)
4. Check that both plug connections are secure. (Figure 3).

will perform as required for the circuit to which it is connected. A Power Sensor test set, type PST-1, can be used to check all operations of the system except the breaker mounted CT's which can be checked for continuity with an ohmmeter.

Since the CT's are checked at numerous points during the assembly process, a continuity check showing that the resistance of the CT on one pole agrees with the resistance of the similar CT on the other two poles is sufficient.

ON SITE POWER SENSOR SYSTEM CHECK
(High Current-Low Voltage Tests)

The check-out of AK type Power Sensor breakers at the time of installation includes a visual inspection as shown under the section titled "Inspection", page 3.

In some cases an on the site check of the breaker under overcurrent conditions is necessary. The purpose of overcurrent testing of trip devices in the field should be to determine if the breaker

When performing single phase checks on the ground fault equipped breakers, it is necessary to short terminals one and five at the ground signal terminal board on the back frame of the breaker. Shorting of the ground signal must be a high integrity connection since voltages in the range of .25 volt peak will cause operation of the ground fault circuit. Terminals one and five can be identified by the .15 micro-farads capacitor connected between them. (See Figure 4)

The following equipment will be necessary to make overcurrent tests:

See NOTE ON Pg # 6

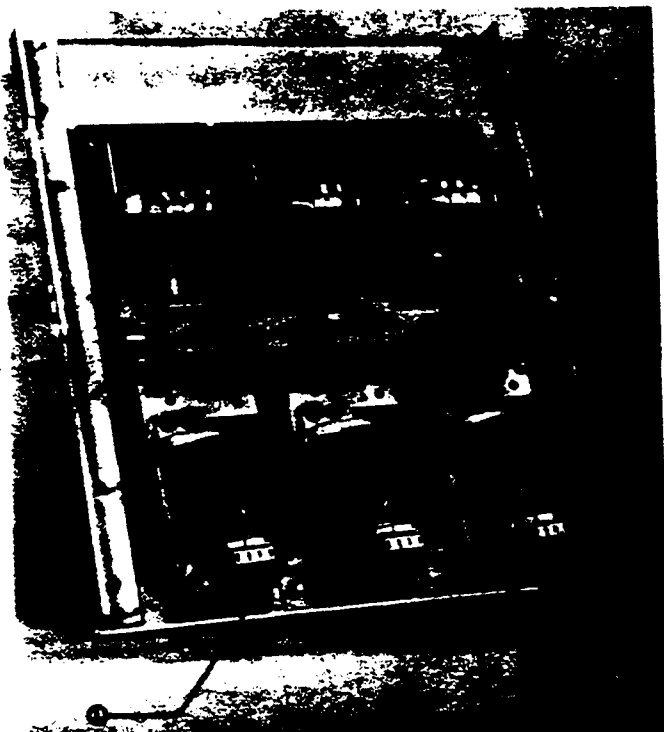

Figure 1. (8041487) Backframe for AK-3-50 Breakers showing Coil Assembly

1. Sensor CT taps
2. Disconnect plug

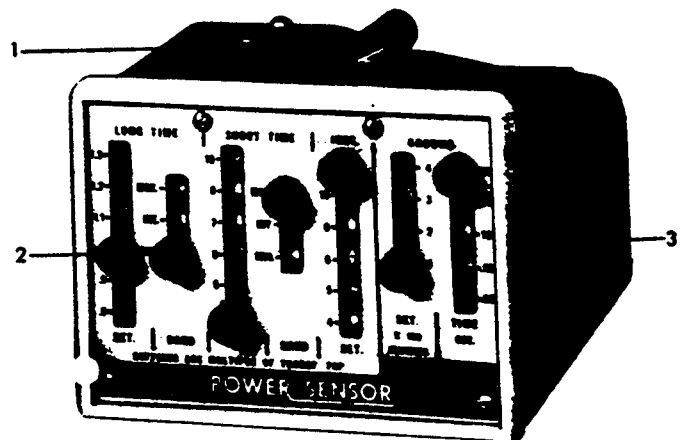

Figure 2. (8039649) Power Sensor Unit

1. Mounting Screw
2. Tap Selector Knobs
3. Name Plate

1. A high current-low voltage test set and a suitable timer.
2. A type PST-1 test kit.
3. A Volt-ohm-milliammeter (in good calibration).
4. A 20 micro-henry air core reactor.

CAUTION

THE POWER SENSOR TRANSFORMER TAP SELECTORS MUST BE CONNECTED AT ALL TIMES ON ALL PHASES. THE DISCONNECT PLUG CONNECTING THE FRONT FRAME WIRING TO THE BACK FRAME WIRING MUST BE CONNECTED BEFORE ENERGIZING THE POWER CIRCUIT. FAILURE TO ENSURE CONNECTIONS WILL RESULT IN DAMAGE TO THE COILS.

Adequate overcurrent testing at installation would include one overcurrent trip on each pole of the breaker using the lowest set function that has been supplied on the particular Power Sensor system. On breakers equipped with the Ground function a Ground trip test should also be performed. The suggestion to alternate the pole of the breaker used in the test is made to ensure that the output of each breaker mounted CT is tested. For example, a Power Sensor system supplied with Long Time Delay, Short Time Delay, and Ground Fault detection could be tested at its Long Time Delay setting, as received, on each pole of the breaker and at its Ground Fault setting as received.

The following methods can be used in making the appropriate test at installation. Included are:

Long Time Delay Test - Timing or,
Short Time Delay Test - Pickup or,

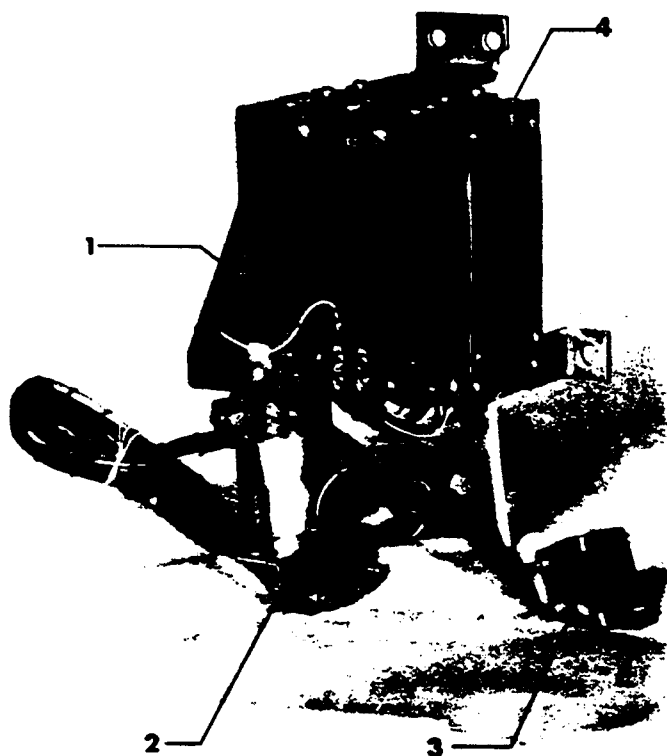

Figure 3A. (8041488) Power Supply AK-50, 75 and 100 Breakers

1. Terminal Block
2. Male Disconnect Plug
3. Female Disconnect Plug
4. Rating Disc

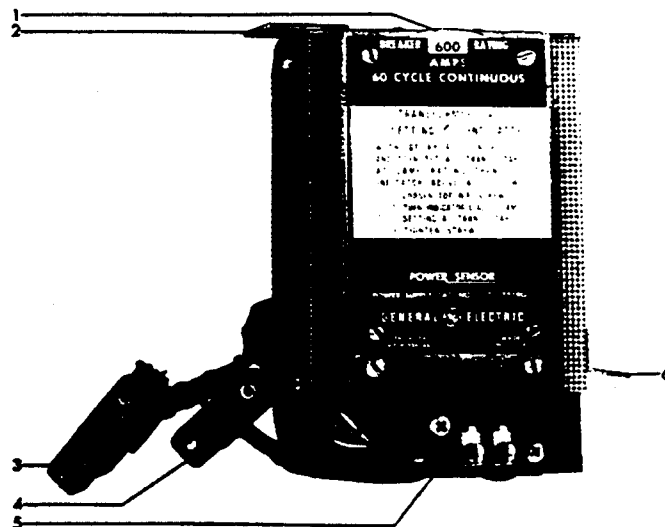

Figure 3B. (8039850) Power Supply AK-25

1. Rating Disconnect
2. Mounting Bracket
3. Male Disconnect Plug
4. Female Disconnect Plug
5. Terminal Block
6. Mounting Bracket

GEK-7309 Test Instructions - Power Sensor Breakers

Instantaneous Trip Test - Pickup and
Ground Fault Detection - Pickup, if included.
100 Volt Bus Test

LONG TIME DELAY TEST - TIMING

Power Sensor Settings:

LTD set for the particular breaker application.
All other trip functions set to maximum settings.

With the test truck connected to one pole of the breaker, apply test current equal to some convenient multiple of the CT tap setting. 300% of the CT tap setting is suggested because this one test point is adequate to ensure proper operation of the trip device. The trip times at this

test point are not too long and the test currents do not result in severe duty to the test equipment. (It must be remembered that repeated testing at high multiples of the continuous current rating will cause heating of the breaker contacts, and increased contact wear.)

Trip time at 3X current as found on the time current curves is:

MIN = 25 sec \pm 20%, INT = 75 sec \pm 20%
MAX = 150 sec. \pm 20%. The (X) is in multiples of the CT tap setting and is independent of the LTD pickup setting on the logic unit.

The LTD circuit operates so that the trip

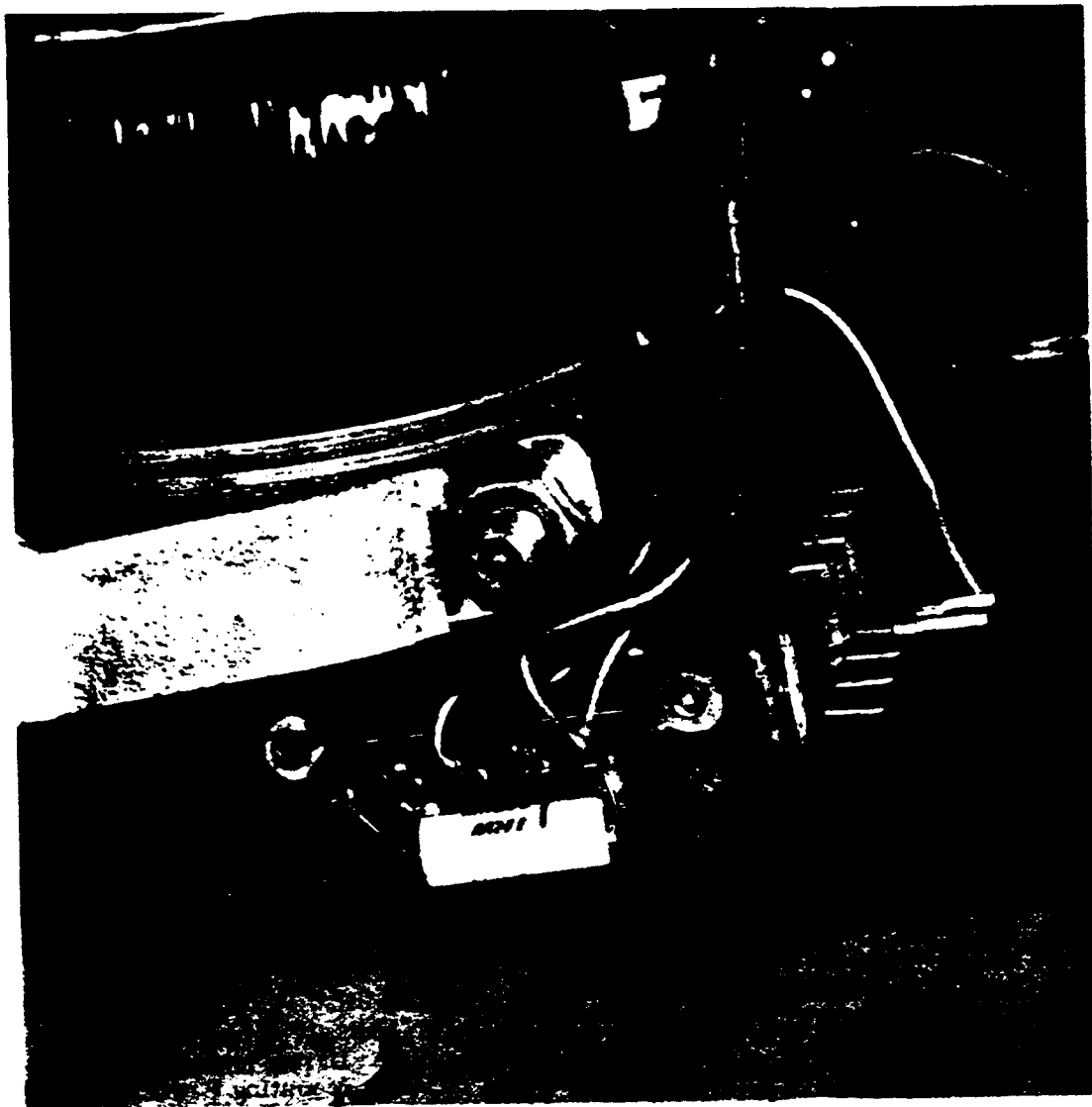

Figure 4 (8041489) Ground Signal Terminal Board (AK-3-50 shown).

1. Terminal Board

2. Sensor CT taps

time is equal to a constant divided by the current squared, $t = K/I^2$. A small variation in the actual test current ($\pm 5\%$) could, therefore, result in a $\pm 10\%$ additional variation in time.

The breaker should trip within the time band specified in the appropriate time-current curve when the comments in the above paragraph are considered. Repeat this test on the two remaining poles of the breaker.

NOTE: When testing AK-75 and AK-100 breakers it has been found that tests using the 1500A or 2000A CT tap are more convenient to make. No compromise in timing results will occur. (remember to return all pick-up and CT tap settings to the setting specified for the particular breaker application.)

SHORT TIME DELAY TESTS - PICKUP

If the breaker is not equipped with LTD but is equipped with STD, a test at 110% of the STD pickup setting is adequate to insure proper operation. (If timing is to be checked, use 200% of the pickup setting to avoid the "knee" of the time current curve).

Power Sensor Settings:

STD set for the particular breaker application. All other trip functions set to maximum settings.

With the test truck connected to one pole of the breaker apply test current equal to 110% of the Short Time pickup setting. Observe that the breaker trips. Repeat this test on the two remaining poles of the breaker. Test current should be raised slowly until tripping occurs so that the tester can make note of the trip current level.

INSTANTANEOUS TRIP TESTS

If the breaker is equipped with LTD or STD it is not necessary that the Instantaneous function be tested at the time of installation. If it is desired to test the Instantaneous function it is important that the STD pickup setting be set above the Instantaneous trip setting or the breaker will open at the STD setting before the Instantaneous setting is reached. (There is a noticeable difference between the trip time for a breaker which opens at the STD MAX time setting and one that opens at the Instantaneous trip level. This difference in time will allow testing of overlapping settings such as 12X CT tap setting when the STD is set to 10X. This is not the normal method of testing the Instantaneous function.)

Power Sensor Settings:

STD set above the Instantaneous setting. Instantaneous set to 4X. All other functions set for the particular breaker application.

With the test truck connected to one pole of the breaker apply test current equal to 110% of the Instantaneous pickup setting. Observe that the breaker trips. Repeat this test on the two remaining poles of the breaker. Test current should be raised slowly until tripping occurs so that the tester can make note of the trip current level.

The 4X setting is suggested for this test because at higher current levels repeated testing can result in heating of the breaker contacts and increased contact wear.

GROUND FAULT TESTS

Remove the jumper between terminals one and five. (On four wire systems only, place the jumper so that it simulates a short on the fourth wire CT. This jumper should be placed between the white lead and black lead of the twisted shielded pair at the disconnect plug.) Perform a continuity check as described on drawing 138B2454, page 13 of this manual.

Power Sensor Settings:

All functions should be set for the particular breaker application.

With the test truck connected to one pole of the breaker, raise the current slowly and note the level at which the breaker trips. Compare this level with the trip setting. Trip current should be within -20%, +0% of the set point, however, the ground sensing function is sensitive to the rate of change of current and ground tripping that does not vary more than -30%, +10% from the setting should be considered acceptable. Repeat this test on the two remaining poles of the breaker.

On completion of these tests, remove any temporary jumpers. Perform a continuity check on the Ground circuit using drawing 138B2454. This can be done by disconnecting the 14-socket plug at the Power Sensor Unit, opening the breaker, and racking the breaker to the CONNECT position. Use an ohmmeter to perform a continuity check from point A to C, the circuit contains the ground sensor coils in series and should be continuous. Check continuity from A to R, an open circuit must appear.

The shielding must be continuous and can be checked on 4-wire systems by placing a temporary jumper at the 4th wire CT (in the neutral bus) from the black wire to the shield. With this jumper in place, continuity should exist between C and R when checked at the Power Sensor plug. Remove the jumper at the 4th wire CT, check at the plug for an open circuit between C and R. This establishes continuity of the shield from the plug to the 4th wire CT. On three-wire systems continuity of the shield can be checked by going from R at the plug directly to the shield at each Ground sensor CT.

Before the breaker is placed in service, the sensor CT taps must be set to the correct setting on all three phases. The tap selector knobs on the Power Sensor unit must be correctly set for the particular breaker application, and all disconnect plugs should be connected. Failure to ensure connections will result in damage to the coils.

Polarity of the ground sensor CT should be checked on 3-wire and 4-wire systems to make sure that the white polarity mark on the CT, near the position where the leads are connected, is away from the source in the standard breaker connection. (On reverse fed breakers the 4th wire CT should be installed so that the white polarity mark is toward the source.)

100 VOLT BUS TEST

This test can be performed in one of two ways: (a) using a high current test or (b) using the Power Sensor test set.

When using the high current, you must pass at least 20% to 30% of the breaker maximum current rating. This must be done on each phase. Close the breaker. With a d.c. Voltmeter, check for 100 volts d.c. at terminals of 110 mfd. Electrolytic Capacitor. This capacitor is located on the bottom of the Power Sensor power supply, or the bottom left corner of the back frame. Instructions for using the test set to perform this check are in Instruction Book, GEK-7301.

SERVICING OF AK POWER SENSOR BREAKERS

When a Power Sensor equipped low voltage circuit breaker is suspected of improper operation, it will fall into one of the following three classes: breaker fails to open, breaker fails to close, or breaker opens when it should not do so. It is important to first ascertain that the malfunction is caused by the Power Sensor System. Mechanical interlocks, intermittent secondary disconnects, sneak shunt trip circuits, or inadvertent acts by personnel must be removed as a possible cause of the problem.

Shown below and outlined in Chart I are the steps recommended for locating the faulty item.

IF THE BREAKER WILL NOT OPEN

Perform high current-low voltage tests as described under "On Site Power System Check" on Page 4 of this manual. Proper operation during this test should direct the tester's attention to the power system and the breaker enclosure. Check the power system load for any unusual conditions that could be misinterpreted by the Power Sensor. Check the breaker enclosure.

For analysis of distribution system problems in special situations a Load Analyzing Test Cable is available for use by qualified General Electric Company personnel. (Catalogue number 152C2748). This cable presents the pins in the connection

plug between the power supply section and the logic unit, shown on drawing 133C9018, Figure 7 page 12, so that the actual output of the CT's and the power supply can be displayed on an oscilloscope while the circuit breaker is in service.

If the power system and breaker enclosure check okay or if there is no operation during the high current-low voltage tests, check the breaker trip shaft for binds, check all trip paddles for correct alignment, and check all shunt trips and lockouts for misalignment or incorrect settings. Refer to maintenance manuals GEK-7303 and GEI-50299 for instructions. Mechanically check the shunt trip and Power Sensor solenoid trip devices to assure a successful tripping operation just before the armature reaches the fully closed position, manually push the armature toward the closed position and determine how much further the armature moves after the breaker has tripped. This check to assure "positive trip" is within the tolerance specified in the breaker maintenance manual is important.

If all shunt trips and lockouts are correctly set and aligned, perform a continuity check on the Power Sensor CTs. Refer to Drawing 133C9017 or 133C9018 on pp.11,12 of this manual. Measure resistances of similar coils on adjacent poles. Generally, if resistances balance the coils are good. For exact resistance values contact the factory. A satisfactory check of the CTs at this point would indicate an open Power Sensor connection plug or a problem with the Power Sensor itself. Use the Power Sensor test set and publication GEK-7301 and perform the described A and B Tests. The A Test will isolate the problem to the Power Sensor logic unit. The B Test will identify a power supply, trip relay, or cabling problem. Replace any section found defective by these tests. If no trouble is found, call the factory for further assistance.

IF THE BREAKER WILL NOT CLOSE

Check the equipment interlocks for interference. Check the trip shaft for binds, check all trip paddles to assure that they are properly aligned. Check all shunt trip devices and all lockouts. Misaligned or improperly set lockouts will prevent the breaker from closing resulting in trip free operation. If the above checks are successful, check the closing mechanism of the breaker according to the breaker manual.

IF THE BREAKER OPENS WHEN IT SHOULD NOT

If the breaker is equipped with ground fault protection, determine whether the false tripping is the result of falsely answering an overcurrent trip or a ground trip signal. This may be determined by temporarily eliminating the ground trip function by shorting points one and five at the ground signal terminal board on the back frame of the breaker. Terminals one and five can be identified by the .15uf capacitor connected between them. (See drawing 138B2454, and Figure 4). With the breaker restored to

service and with the ground fault detector deactivated, establish whether there is false tripping due to phase currents. If the ground trip function is at fault check the connection of the ground sensor coils and the polarity indications according to the wiring diagram 138B2454, page 13.

Perform high current-low voltage tests as described under "On Site Power Sensor System Check" on Page 4 of this manual. In this case, it is necessary to test all functions that are supplied with the unit set to the setting for the particular breaker application. Proper operation during this test should direct the tester's attention to the power system and load to determine if actual problem conditions exist.

If improper operation persists, check the alignment of the trip shaft, trip paddles, shunt trips and lockouts. Correct any misalignment or binds. Check the CT taps on the sensor CT tap selector board at the coil assembly to make sure they are connected and securely set at the correct ampere rating. Recheck the ground coil wiring.

Check all plug connections according to 133C9017 or 133C9018 on pp.11, and 12 of this manual. If open, check for damage and check continuity at both plugs. Change the appropriate section to replace the defective plugs. If the plug connections are secure, use publication GEK-7301

to perform the test designated A - test for the Power Sensor System. If the logic unit is bad, replace the logic unit; if good, perform the B test. With the Circuit Breaker open, set the "Signal Adjust" knob fully counter clockwise for a minimum level. Push Electrical "Reset" push Button and push "Start" Push Button.

With a d.c. Voltmeter, check for 100 volts d.c. at terminals of 110 mfd. Electrolytic Capacitor. This capacitor is located on the lower left corner of the backframe next to the CT disconnect plug on AK-3-25 breakers. On the AK-3-50/75/100 breakers, it is located on the bottom of the Power Sensor power supply. Measure this voltage on phase A, phase B and phase C by rotating the selector knob. If voltage does not lie between 95 and 115 volts d.c., the power supply is defective.

A defective system test at this point indicates a bad power supply section. Replace the power supply.

Once the trouble has been located and corrected using this method, the breaker should be placed in the test position and then opened and closed either manually or electrically. Proper operation will indicate that the problem condition has been corrected. Perform the inspection check as indicated on Page 3. The breaker can now be placed in service.

TABLES AND CHARTS

1. Trouble shooting and service diagram, Figure 5, Chart I, Page 10.
2. Power Sensor Cabling Diagram Drawing #133C9017 (Figure 6), and #133C9018 (Figure 7) on pages 11 and 12 of this manual.
3. Ground Fault System wiring drawing #138B2454 (Figure 8) page 13.
4. Time delay ranges for the Long Time Delay Circuit (GEK-7301 page 5).
5. Time overcurrent curves (Packet GEZ-4431).

QUICK CHECK LIST

1. Power Supply Rating disc is set at the correct current rating.
2. Coil taps are set at the correct current rating on all three phases.
3. Tap selector knobs on the Power Sensor Unit are set correctly.
4. All Power Sensor plugs are secure.
5. Shunt trip devices are correctly aligned to contact the trip paddles.
6. Wiring of Ground fault detection CTs, including the fourth wire CT, agrees with drawing #138B2454.

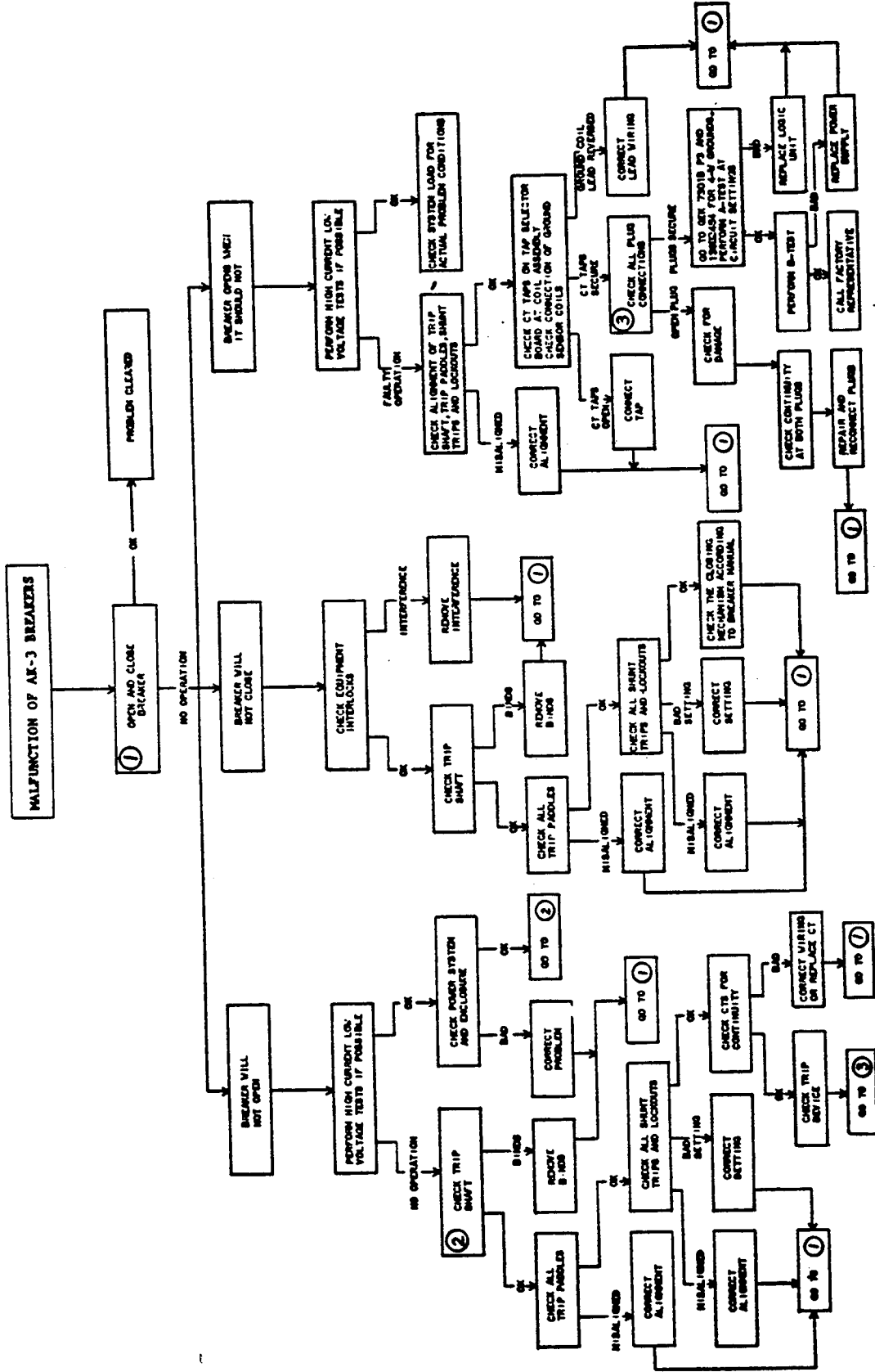

Figure 5. Chart I - Trouble shooting and service diagram.

AK-3-25
POWER SENSOR TRIP CABLING

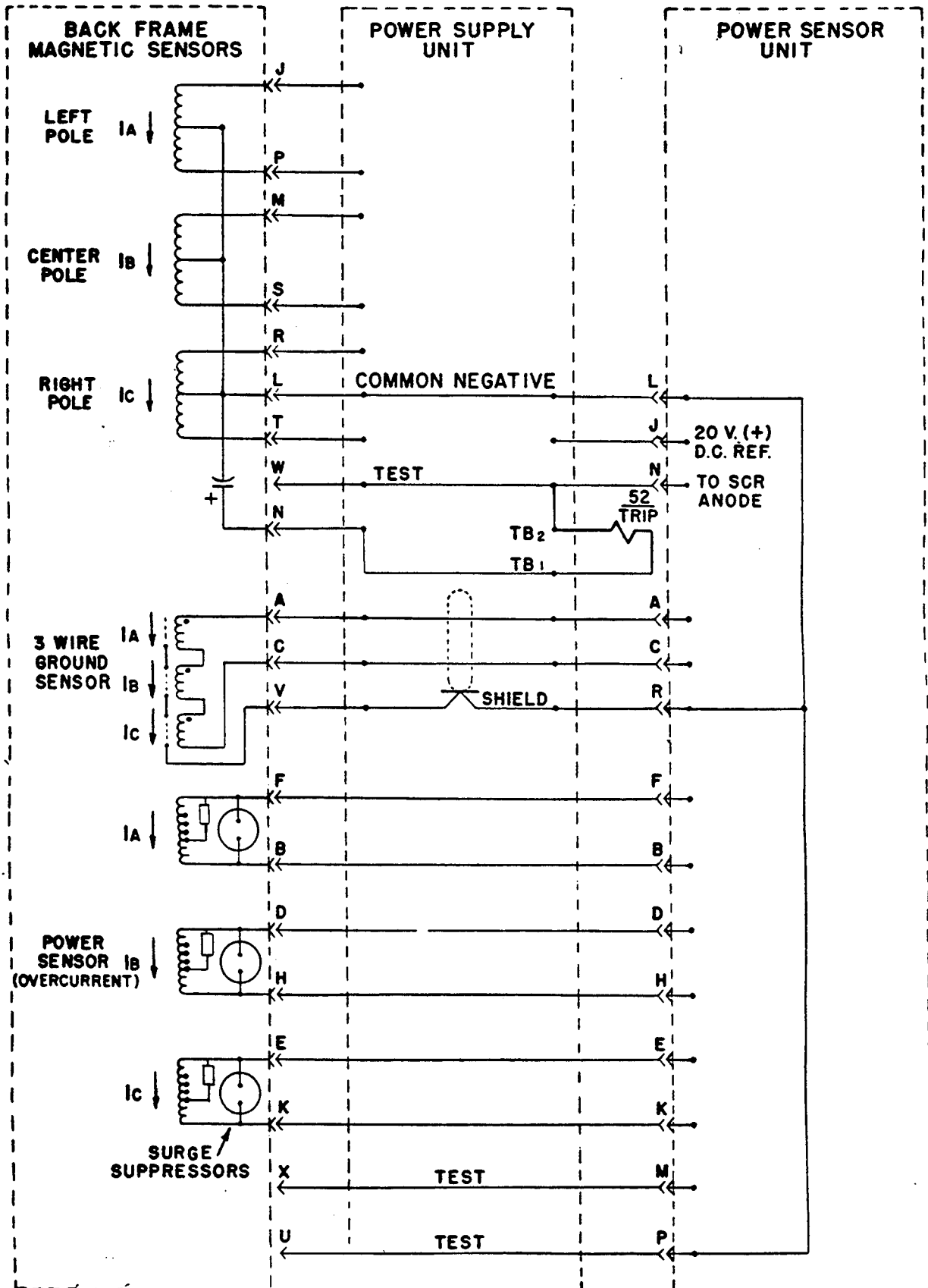

Figure 6. (133C9017-3) Power Sensor Cabling Diagram Drawing

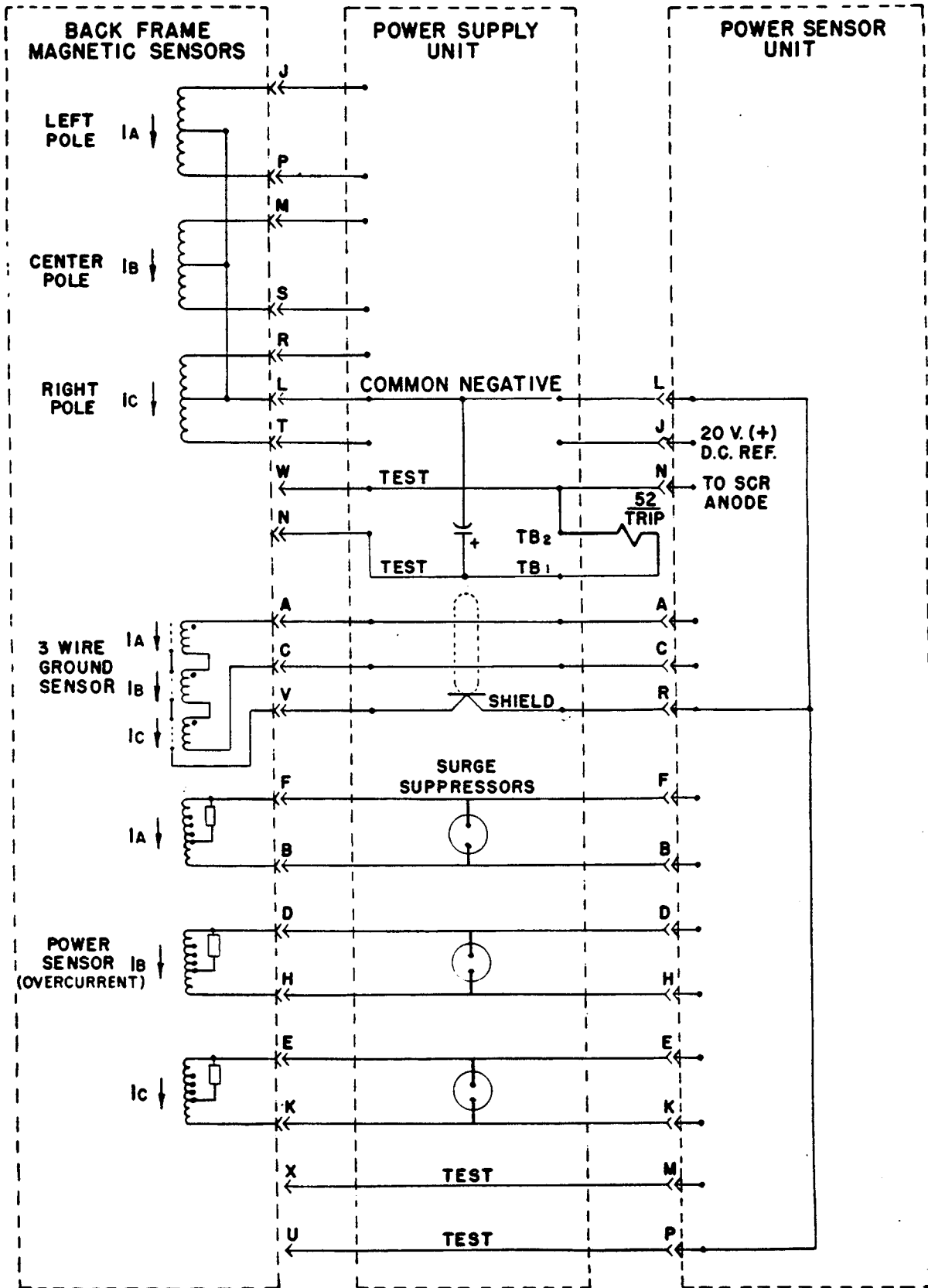
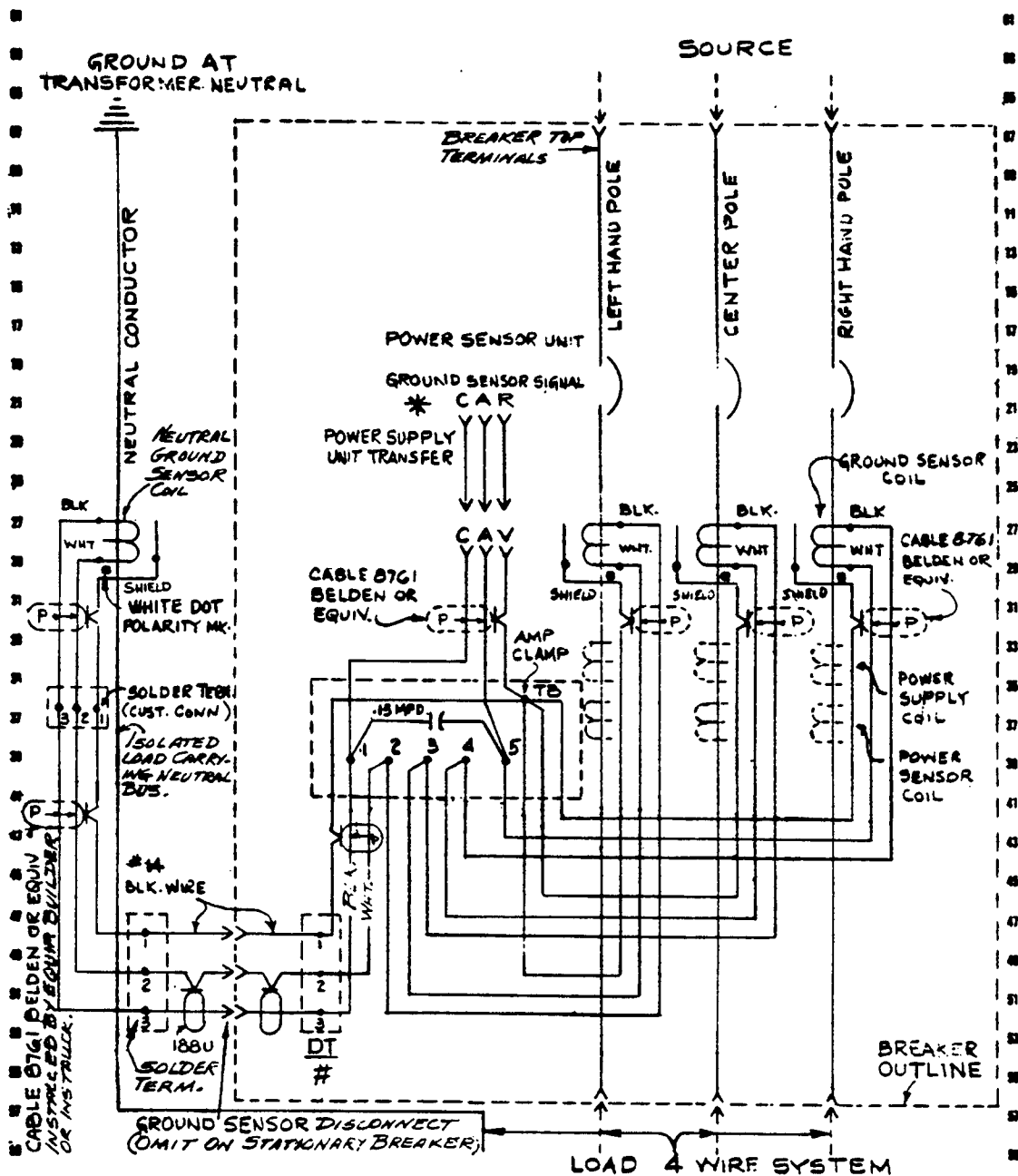

Figure 7. (133C9018-3) Power Sensor Cabling Diagram Drawing
AK-3-50/75/100



INITIAL INSTALLATION OF POWER SENSOR UNIT DISCONNECT

- * CHECK CONTINUITY A TO C
- * CHECK NO CONTINUITY A OR C TO R (SHIELD)
- * CHECK CONTINUITY R TO SHIELD OF NEUTRAL GROUND SENSOR COIL.

TYPICAL GROUND FAULT CONNECTIONS (BREAKER, CABLING, GROUND SENSOR DISCONNECT AND EXTERNAL GROUND SENSOR COIL)

PART OF PS-1 POWER SENSOR TRIP

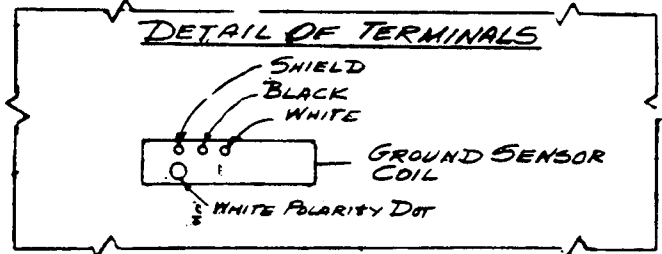

Figure 8. (138B2454-6) Ground Fault System Wiring Diagram

GENERAL ELECTRIC INSTALLATION AND SERVICE ENGINEERING OFFICES

FIELD SERVICE OFFICE CODE KEY	
•	Mechanical & Nuclear Service
†	Electrical & Electronic Service
‡	Marine Service
I	Transportation

FOR YOUR LASTING SATISFACTION... with the performance and availability of your General Electric equipment, GE provides this nationwide network of field service offices, covering utility, industrial, transportation and marine areas. Qualified field engineers provide installation, start-up, employee training, engineering maintenance and other services, throughout the productive life of the equipment. For full information, call your nearest Installation & Service Engineering office.

<p>ALABAMA † Birmingham 36208 2151 Highland Ave. • † ‡ Mobile 36609 1111 S. Beltline Highway</p> <p>ALASKA † Anchorage 99501 118 Whitney Rd.</p> <p>ARIZONA • † Phoenix 85012 2640 N. Central Ave. † Tucson 85716 151 S. Tucson Blvd.</p> <p>ARKANSAS † North Little Rock 72119 130 Main St.</p> <p>CALIFORNIA • † ‡ Los Angeles 90094 213 N. Vignes St. † Palo Alto 94303 940 San Antonio Rd. † Sacramento 95808 3407 J St. † San Diego 92103 2840 First Ave. • † San Francisco 94119 55 Hawthorne St. • † ‡ Vero Beach 32984 3038 E. 49th St.</p> <p>COLORADO • † Denver 80204 301 University Blvd.</p> <p>CONNECTICUT • † Meriden 06460 1 Prestige Dr.</p> <p>FLORIDA † ‡ Jacksonville 32203 4040 Woodcock Dr. † ‡ Miami 33134 4100 W. Flagler St. • † ‡ Tampa 33609 2106 S. Lois Ave.</p> <p>GEORGIA • † ‡ Atlanta 30309 1800 Peachtree Rd., NW † ‡ Savannah 31406 5002 Paulsen St.</p> <p>HAWAII † ‡ Honolulu 96813 440 Coral St.</p> <p>ILLINOIS • † ‡ † Chicago 60690 840 S. Canal St.</p> <p>INDIANA † Evansville 47706 2709 Washington Ave. † Fort Wayne 46807 3606 S. Calhoun St. • † Indianapolis 46207 3750 N. Meridian St.</p> <p>IOWA † † ‡ Des Moines 52806 P. O. Box 630, 1039 State St., Bettendorf</p> <p>KENTUCKY † Louisville 40218 2300 Meadow Dr.</p>	<p>LOUISIANA • † † Baton Rouge 70806 8312 Florida Blvd. • † ‡ New Orleans 70125 4747 Earhart Blvd. • † ‡ Shreveport 71104 2640 Centenary Blvd. † † ‡ Monroe 71201 1028 North 9th St.</p> <p>MARYLAND • † ‡ Baltimore 21201 1 N. Charles St.</p> <p>MASSACHUSETTS • † ‡ Wellesley 02181 1 Washington St.</p> <p>MICHIGAN • † ‡ Detroit 48202 700 Antoinette St. † † Jackson 49201 210 W. Franklin St. † † Saginaw 48607 1008 Second National Bank Bldg.</p> <p>MINNESOTA • † † † Duluth 55802 300 W. Superior St. • † † † Minneapolis 55416 1500 Lilac Drive So.</p> <p>MISSOURI • † † † Kansas City 64199 911 Main St. • † † † St. Louis 63101 1015 Locust St.</p> <p>MONTANA † † Butte 59701 103 N. Wyoming St.</p> <p>NEBRASKA • † † Omaha 68102 409 S. 17th St.</p> <p>NEW JERSEY • † † Milburn 07041 25 E. Willow St.</p> <p>NEW YORK † † Albany 12205 15 Computer Drive, West • † † Buffalo 14205 625 Delaware Ave. • † † † New York 10023 64 Lexington Ave. • † † Rochester 14604 89 East Ave. • † † Syracuse 13206 3532 James St.</p> <p>NORTH CAROLINA • † † Charlotte 28207 141 Providence Rd. • † † Wilmington Reigelwood 28456 P. O. Box 186</p> <p>OHIO • † † Cincinnati 45206 2621 Victory Pkwy. • † † Cleveland 44104 1000 Lakeside Ave. † † Columbus 43229 1110 Morse Rd. † † Toledo 43606 3125 Douglas Rd. † † Youngstown 44507 272 Indiana Ave.</p>	<p>OKLAHOMA • † † Oklahoma City 73108 2000 Chascom Blvd. † † Tulsa 74105 P. O. Box 7646, Southside St.</p> <p>OREGON † Eugene 97401 1170 Pearl St. • † † Portland 97210 2929 NW 29th Ave.</p> <p>PENNSYLVANIA • † Allentown 18102 1444 Hamilton St. • † † Philadelphia 19102 3 Penn Center Plaza • † Pittsburgh 15223 300 6th Avenue Bldg.</p> <p>SOUTH CAROLINA † † † Columbia 29204 2700 Middleburg Dr. † † Greenville 29607 41 No. Pleasantburg Dr.</p> <p>TENNESSEE • † Chattanooga 37411 5800 Bldg, Eastgate Center † † Memphis 38130 3385 Airways Blvd.</p> <p>TEXAS • † † Amarillo 79101 303 Polk St. • † † † Beaumont 77704 1285 Calder Ave • † † Corpus Christi 78401 305 N. Chaparral St. • † † Dallas 75232 8101 Stammont Freeway • † † El Paso 79945 215 N. Stanton † † Fort Worth 76102 408 W. Seventh St. • † † Houston 77027 4219 Richmond Ave. † † San Antonio 78204 434 S. Main St.</p> <p>UTAH † † Salt Lake City 84111 431 S. Third East St.</p> <p>VIRGINIA • † Newport News 23601 311 Main St. † † Richmond 23230 1508 Willow Lawn Dr. † † Roanoke 24015 2018 Colonial Ave.</p> <p>WASHINGTON • † † Seattle 98188 112 Andover Park East, Tukwila † † Spokane 99202 E. 1806 Trent Ave.</p> <p>WEST VIRGINIA • † † Charleston 25328 306 MacCorkle Ave., SE</p> <p>WISCONSIN • † † Appleton 54911 3003 West College Dr. • † † Milwaukee 53202 615 E. Michigan St.</p>
--	--	--

GENERAL ELECTRIC SERVICE SHOPS

WHEN YOU NEED SERVICE... These GE Service Shops will repair, recondition, and rebuild your electric apparatus. The facilities are available day and night, seven days a week, for work in the shops or on your premises.

Latest factory methods and genuine GE renewal parts are used to maintain performance of your equipment. For full information about these services, contact your nearest service shop or sales office.

<p>ALABAMA • † Birmingham 35211 1800 Mims Ave., S.W. • † Mobile 36609 721 Lakeside Dr.</p> <p>ARIZONA • (Phoenix) Glendale 85019 4911 W. Colter St. • Phoenix 85019 3940 W. Clarendon St. • Tucson 85713 2942 So. Palo Verde Ave.</p> <p>CALIFORNIA • † Los Angeles 90301 6800 Stanford Ave. • (Los Angeles) Anaheim 92805 3601 E. LaPalma Ave. • (Los Angeles) Inglewood 90301 228 W. Florence Ave. • Sacramento 95814 99 North 17th St. • (San Francisco) Oakland 94608 1660 34th St.</p> <p>COLORADO • † † Denver 80208 3383 Larimer St.</p> <p>CONNECTICUT • † (Bouthington) Plainville 06470 370 Arwater St.</p> <p>FLORIDA • † Jacksonville 32203 2020 W. Beaver St. • (Miami) Hialeah 33010 1043 East 28th St. • † † Tampa 33601 19th & Grand Sts.</p> <p>GEORGIA • † (Atlanta) Chamblee 30341 5035 Peachtree Industrial Blvd. • † Atlanta 2379 John Glenn Dr.</p> <p>ILLINOIS • † Chicago 60636 6045 S. Nottingham Ave.</p> <p>INDIANA • † Evansville 47711 401 N. Congress Ave. • † Ft. Wayne 46803 1731 Edsall Ave. • † Hammond 46330 1138 164th Place • † Indianapolis 46223 1740 W. Vermont St.</p> <p>IOWA • † (Des Moines) Bettendorf 52723 1026 State St.</p> <p>KENTUCKY • † Louisville 40209 3900 Critchfield Drive</p>	<p>LOUISIANA • † Baton Rouge 70814 10955 North Dual St. • † New Orleans 70114 1115 DeArmas St.</p> <p>MARYLAND • † Baltimore 21230 920 E. Fort Ave.</p> <p>MASSACHUSETTS • † Boston Medford 02155 3960 Mystic Valley Pkwy.</p> <p>MICHIGAN • † (Detroit) Riverview 18075 Krause Ave. • † Flint 48505 1506 E. Carpenter Rd.</p> <p>MINNESOTA • † † Duluth 55807 50th Ave. W & St. Louis Bay • † † Minneapolis 55430 2025 49th Ave., N.</p> <p>MISSOURI • † † Kansas City 64120 3525 Gardner Ave. • † † St. Louis 63110 1115 East Rd.</p> <p>NEW JERSEY • † † New Brunswick 08902 3 Lawrence St.</p> <p>NEW MEXICO • † Albuquerque 87109 4420 McLeod Rd. NE</p> <p>NEW YORK • † Albany 12205 1097 Central Ave. • † (Buffalo) Tonawanda 14150 175 Milens Rd. • † (Long Island) Old Bethpage 11804 83 Bethpage-Sweet Hollow Rd. • † (New York City) North Bergen, N.J. 07012 8001 Tomelle Ave. • † (New York City) Clifton, N.J. 07013 9 Brighton Rd. • † Schenectady 12306 1 River Rd. • † Syracuse 13206 1815 E. Shawana Blvd.</p> <p>NORTH CAROLINA • † † Charlotte 28206 3386 Thrift Rd.</p> <p>OHIO • † Akron (Canton) 44720 7800 Whipple Ave. N.W. • † Cincinnati 45202 444 West 3rd St. • † Cleveland 44125 4477 East 49th St. • † Columbus 43229 9640 Huntley Rd. • † Toledo 43605 406 Dunstons Ave. • † Youngstown 44507 378 E. Indiana Ave.</p>	<p>OKLAHOMA • † Tulsa 74145 5220 S. 100th East Ave.</p> <p>OREGON • † Eugene 97402 570 Wilson St. • † Portland 97210 2727 NW 29th Ave.</p> <p>PENNSYLVANIA • † Allentown 18103 608 E. Highland St. • (Delaware Valley) Cherry Hill, N.J. 08034 1780 E. Marlton Pike • † Johnstown 15402 841 Oak St. • † Philadelphia 19124 1040 East Erie Ave. • † (Pittsburgh) West Mifflin 15122 4930 Buttermilk Hollow Rd. • † York 17403 54 N. Harrison St.</p> <p>SOUTH CAROLINA • (Charleston) No. Charleston 29401 2490 Debonair St.</p> <p>TENNESSEE • † Knoxville 37914 3821 Governor John Sevier Hwy. • † Memphis 38107 708 North Main St.</p> <p>TEXAS • † Beaumont 77705 1490 W. Cardinal Dr. • † Corpus Christi 78401 115 Waco St. • † Dallas 75235 3202 Manor Way • † Houston 77034 5534 Harvey Wilson Dr. • † Houston 77036 6916 Hurwin Dr. • † Midland 79701 704 S. Johnston St.</p> <p>UTAH • † Salt Lake City 84130 301 S. 7th West St.</p> <p>VIRGINIA • † Richmond 23234 1403 Ingram Ave. • † Roanoke 24013 1004 River Ave., SE</p> <p>WASHINGTON • † Seattle 98134 3423 First Ave., South • † Spokane 99211 E. 4323 Mission St.</p> <p>WEST VIRGINIA • † Charleston 25328 306 MacCorkle Ave., SE</p> <p>WISCONSIN • † (Appleton) Menasha 54910 1725 Racine St. • † Milwaukee 53207 236 W. Oklahoma Ave.</p>
--	---	---

• Electrical/Mechanical Service Shop • Instrumentation Shop • Special Manufacturing Shop



GROUND FAULT DEFEAT CABLE — TGFD

GENERAL

Circuit breakers equipped with either the SST or Versa Trip protection programmer and integral ground fault protection will require the use of the Ground Fault Defeat Cable (Fig. 1) when performing on-site high-current testing of long time/short time and instantaneous trip functions. These breakers utilize internally mounted current transformers (C.T.'s) to sense current flow in each breaker pole. A fourth C.T., (Neutral C.T.) is supplied for external mounting, when ordered, for 3 phase 4-wire systems.

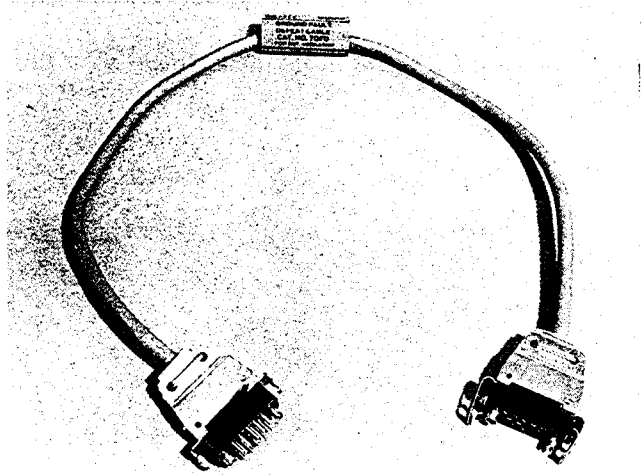

The C.T.'s provide the protection programmer with a low level signal proportional to current flow in each phase. The protection programmer in turn utilizes these signals to supply its own power needs and analyzes them for circuit protection. When integral ground fault protection is supplied, the vector sum of these signals must equal zero. That is, all current flowing through the breaker towards the load must also return through the breaker — or neutral C.T. if used. If this does not occur, the programmer will identify the resulting error signal as a ground fault and trip the breaker when its magnitude reaches the set point level of the programmer.

This situation may be encountered when conducting single phase high current tests. The Ground Fault Defeat Cable, when installed, essentially cancels the ground fault function and thus permits single phase testing of the long time/short time and instantaneous trip points.

SAFETY PRECAUTIONS

WARNING: Ensure that the breaker is "OPEN" or "TRIPPED" and completely disconnected from all power sources prior to connecting or disconnecting the TGFD cable.

NOTE: The Ground Fault Defeat Cable (TGFD) cannot be used when performing ground fault testing of breaker. Do not use the TGFD cable when using the portable low current SST or Versa Trip test sets.

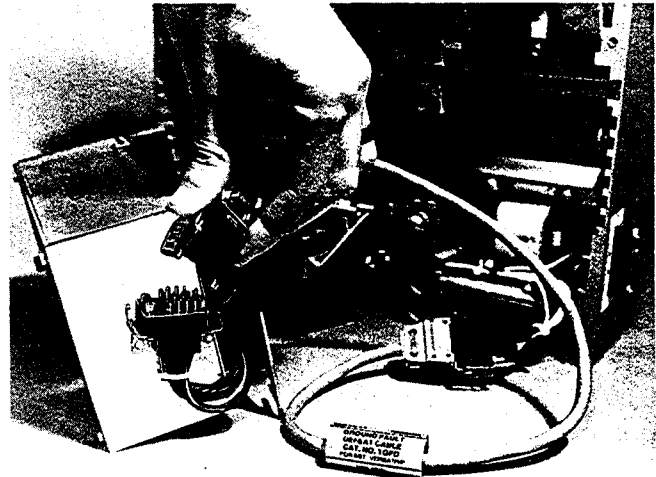

INSTALLATION

Disassemble breaker, as required, to gain access to protection programmer. Refer to Fig. 2 for typical TGFD installation and proceed as follows:

1. Disconnect connector from the back of the breaker programmer.
2. Connect the TGFD cable female connector end to connector in back of the protection programmer.
3. Connect the male end of the TGFD cable connector to the female connector of the breaker wiring harness end.
4. Close the breaker, then perform "Hi-current" testing as required for long time/short time and instantaneous breaker trip operation.
5. Remove TGFD cable and reconnect breaker wiring harness to protection programmer. Re-assemble breaker.
6. Perform "Hi-current" testing as required for ground fault function.

These instructions do not purport to cover all details or variations in equipment nor to provide for every possible contingency to be met in connection with installation, operation or maintenance. Should further information be desired or should particular problems arise which are not covered sufficiently for the purchaser's purposes, the matter should be referred to the General Electric Company.

GENERAL  **ELECTRIC**

**Installation
Instructions**
TVTGD4
TVTGD9



Micro-VersaTrip[®] Programmer

Ground Fault Defeat Modules

General

Occasionally it is desirable to perform on-site testing of a circuit breaker's Long Time/Short Time and Instantaneous trip functions using a single phase, low voltage, high current test set (i.e. primary high current injection directly into one pole of the circuit breaker). When using this test method with circuit breakers equipped with Micro-VersaTrip[®] solid state programmers having a Ground Fault trip function, a TVTGD Ground Fault Defeat Module must be used.

Circuit breakers used with Micro-VersaTrip programmers have internally mounted current sensors (transformers) to sense the current in each breaker pole. An additional externally mounted sensor (neutral sensor) is used for three phase, four wire systems. When ground fault protection is supplied, the three-phase vector sum of these currents must equal zero. If this does not occur (as is the case with single phase testing) the programmer will identify the resulting error signal as a ground fault and trip the breaker when the error signal reaches the set point of the programmer's ground fault trip function.

The Ground Defeat Module, essentially defeats the ground fault function, thus permitting single phase testing of the Long Time/Short Time and Instantaneous trip points.

The Ground Fault Defeat Module cannot be used when performing ground fault testing of the breaker. Also, do not use it when using the portable TVTSD Micro-VersaTrip test set.

Safety Precautions

WARNING:

1. Ensure that the breaker is "OPEN" and is completely disconnected from its power source prior to connecting or disconnecting the Micro-VersaTrip programmer or the TVTGD defeat module. Never open circuit the current sensors while the circuit breaker is carrying current as this will allow dangerous and damaging voltages to develop. The current sensors must always be connected to the Micro-VersaTrip programmer, either directly or through the TVTGD module when the circuit breaker is carrying current.

2. At the completion of testing, trip the circuit breaker and ensure that the TVTGD module is removed and the Micro-VersaTrip programmer is properly reinstalled in the circuit breaker. Failure to do so will result in a loss of circuit protection.

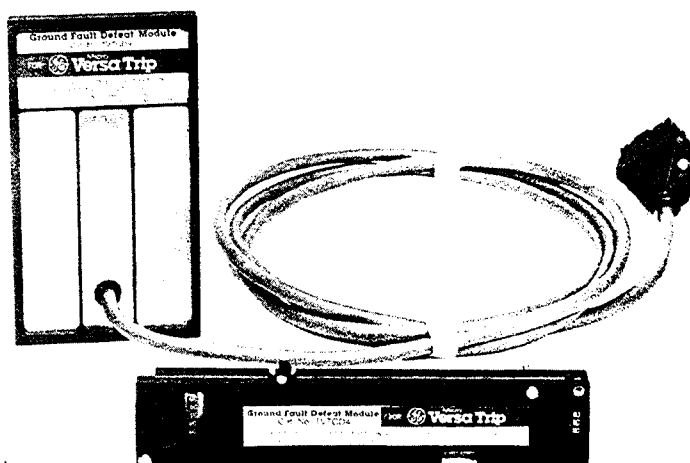

Installation

TVTGD4 Module

(For use with circuit breakers using Micro-VersaTrip programmer type T4VT).

1. Push the "PUSH TO TRIP" button on the front of the circuit breaker.
2. Remove the cover protecting the Micro-VersaTrip programmer.
3. Carefully remove the two-pin flux shifter trip coil connector at the top of the programmer.
4. Loosen completely the two captive screws that secure the programmer to the sensor (current transformer) package. The programmer may now be removed.
5. Plug the TVTGD4 module into the sensor package. Gently tighten the two mounting screws.

6. Plug the Micro-VersaTrip T4VT programmer into the TVTGD4 Ground Fault Defeat Module. Gently tighten the two mounting screws.
7. Connect the two-pin flux shifter trip coil connector to the Micro-VersaTrip T4VT programmer.
8. Proceed to test.
9. To reinstall the programmer, trip the breaker and reverse this procedure.

TVTGD9 Module

1. Trip (open) the circuit breaker.
2. Remove the circuit breaker cover where applicable.
3. Remove the programmer from its plug in base, by releasing the cover interlock mechanism and applying a gentle rocking motion to the programmer as it is removed.

4. Install the TVTGD9 Ground Fault Defeat Module in the circuit breaker plug in base where the programmer was previously connected.
5. Connect the TVTGD9 cable connector to the Micro-VersaTrip programmer.

NOTE: If the circuit breaker has a cover interlock mechanism such as in POWER BREAK circuit breakers, it will be necessary to install the circuit breaker cover in order to close the circuit breaker. This means that the connector cable from the defeat module must be routed through the programmer window in the cover before the cover is applied.

6. Proceed to test.
7. To reinstall the programmer, trip the breaker and reverse this procedure.

These instructions do not purport to cover all details or variations in equipment nor to provide for every possible contingency to be met in connection with installation operation or maintenance. Should further information be desired or should particular problems arise which are not covered sufficiently for the purchaser's purposes, the matter should be referred to the General Electric Company. These instructions are intended for use by qualified personnel only.

For further information
call or write your local
General Electric
Sales Office or...

Distribution Equipment
Division
41 Woodford Avenue
Plainville, CT 06062 U.S.A.

Outside the U.S. and Canada write: Export Sales and Services,
570 Lexington Avenue, New York, NY 10022 U.S.A.

GEK-64466 PS.B 1/82

GENERAL  **ELECTRIC**



Ground Fault Protection Systems

Performance Testing

Performance Testing Ground Fault Protection Systems

CONTENTS

DESCRIPTION	PAGE
General Information	2
Checklist for G.F. Testing	3
Test Methods	3,4
Test Equipment	4
Notes on Testing	4
Test Diagrams for Systems with G.F. Relays	5 to 12
Test Diagrams for Systems with Integral G.F.P.	13 to 16
Test Record Forms	17 to 20

The Circuit Diagrams included in this manual are for illustration of typical applications and are not intended as constructional information. Although reasonable care has been taken in their preparation to assure their technical correctness, no responsibility is assumed by the General Electric Company for any consequences of their use.

The devices and arrangements disclosed herein may be covered by patents of General Electric Company or others. Neither the disclosure of any information herein nor the sale of devices by General Electric Company conveys any license under patent claims covering combinations of devices with other devices or elements.

In the absence of any express written agreement to the contrary, General Electric Company assumes no liability for patent infringement arising out of any use of the devices or elements by any purchaser of devices or others.

PURPOSE

The purpose of this publication is to provide instructions for testing ground fault protection (GFP) systems in General Electric low-voltage equipment. These instructions are for use with equipment built by the Distribution Equipment Division, in accordance with the National Electrical Code, Section 230-95.

NEC 230-95(c) reads as follows:

(c) The ground fault protection system shall be performance tested when first installed. The test shall be conducted in accordance with approved instructions which shall be provided with the equipment. A written record of this test shall be made and shall be available to the authority having jurisdiction.

INSTRUCTIONS APPLICABLE TO

EQUIPMENT

Switchboards:
Type AV & Powerbreak

Low-Voltage Switchgear:
AKD-6 & AKD-8

CIRCUIT BREAKERS

Insulated-Case & Molded Case Breakers with VersaTrip, SelecTrip or MicroVersaTrip Trip.

LV Power Circuit Breakers
Type AKR with SST or Micro VersaTrip Trip.

FUSIBLE SWITCH

Type HPC/HPR High Pressure Contact Switch with Integral Ground Fault Tripping

GROUND FAULT RELAYS & SENSORS

Ground-Break System or similar ground fault relays and sensors (CT's) used to trip any circuit breaker or switch with a shunt trip.

TESTING BY QUALIFIED PERSONNEL

Performance testing of the ground fault protection system should be undertaken only by qualified personnel. Particularly in the tests requiring the use of a high-current test set, it is usually necessary to obtain the services of a qualified testing organization. General Electric's Installation and Service Engineering organization and the Apparatus Service Shops are qualified and equipped to provide this testing service.

Checklist For Ground Fault Performance Testing

PROBLEMS THAT MAY BE ENCOUNTERED THAT CAN PREVENT PROPER GFP OPERATION	HOW TO CHECK FOR THIS CONDITION
<p>1. On 3-phase 4-wire systems, the neutral conductor should not have additional grounding connections made downstream from the main bonding jumper which must be located in the service entrance section. (Refer to NEC 250-23). This condition may cause loss of sensitivity in sensing ground fault current.</p>	<p>By visual inspection.</p> <p>By measurement of resistance between neutral conductor and ground bus.</p> <p>In the high-current tests this condition may be the cause if it takes over 150% of G.F. current setting to initiate tripping.</p>
<p>2. Neutral sensor in residual sensor arrangements or with integral G.F. trip breaker may be installed with incorrect polarity with respect to the associated phase sensors. This will cause false tripping by reading balanced load current as imbalanced and interpreting the error signal as a fault situation.</p> <p>3. Neutral conductor in a load circuit must pass through a zero-sequence sensor in the same direction as the phase conductors. Unbalanced signals cause false tripping.</p> <p>4. When a given circuit is monitored by a zero-sequence sensor, none of the conductors shall be omitted from passing through the sensor. Unbalanced signals cause false tripping.</p>	<p>By visual inspection.</p> <p>In the high-current testing the "no-trip" tests will detect this condition.</p>
<p>5. An equipment bonding or grounding conductor must not be passed through the window of a G.F. sensor. This will cause cancellation of error signals, and will prevent G.F. tripping when it is needed.</p>	<p>Inspect load cables and grounding connections between conduits and the switchboard ground bus. The grounding connections must not pass through a zero-sequence sensor, with phase and neutral wires.</p>
<p>6. The ground fault protection may be rendered inoperable by damaged wiring or devices, blown or missing control fuses, or lack of tripping power when supplied from a remote source.</p>	<p>If the high-current tests do not produce expected tripping, check for control power at transformers, at fuses, and at relays.</p>

Testing Methods

GENERAL

There are two alternate test methods for evaluating ground fault protection (GFP) systems — by using simulated fault current or by high-current primary injection. Both test methods are applicable to ground-fault relay systems, but only the high-current primary injection method can be used to test a system with integral ground-fault trip circuit breakers.

If it is acceptable to the local inspection authorities, ground fault relay systems may be tested by the simulated fault current testing method combined with a thorough visual inspection. Otherwise, it will be necessary to use the high-current primary injection test method.

GROUND FAULT PROTECTION TESTING WITH SIMULATED FAULT CURRENT

In the simulated fault current method, a simulated fault current is generated by a coil around a window-type sensor or by means of a separate test winding in the sensor. When the monitor panel sends a small current through the test winding, it produces a secondary current in the sensor which the relay responds to as if it were caused by a primary current of 1600 amperes.

In an equivalent method which can be used with any window-type sensor supplying a ground fault relay, a number of turns of wire are wrapped around the sensor core, such as twenty turns of #14 wire. A current of approximately 125 percent of the pickup setting of the relay divided by the number of turns is passed through the wire to simulate the ground-fault current. By setting the relay pickup to the low end of the range, the test current may be kept to a minimum.

Testing with simulated fault current provides a means of demonstrating the operation of the sensor, relay and shunt trip and the adequacy of the control power supply. In addition to these items, the GFP system must be checked to confirm that neutral ground points are located correctly with respect to sensors, that sensor polarities are correct when several are connected in parallel, and that conductors which pass through a sensor window all run in the same direction. If done thoroughly by a qualified person, a visual inspection can confirm that these items have been taken care of correctly.

The importance of supplementing simulated fault current testing with an adequate inspection is emphasized when one realizes that the first five items on the Checklist (see above) are problems that can *NOT* be detected by simulated fault current testing alone.

Testing Methods

Continued

GROUND FAULT PROTECTION TESTING BY HIGH-CURRENT PRIMARY INJECTION

The high-current injection test method may be used to test GFP systems with either ground fault relays or integral ground fault trips on circuit breakers. With relays, it is an alternative to simulated fault-current testing supplemented by inspection. We recommend it as the best way to test the performance of GFP systems with relays.

Integral ground fault protection in circuit breakers can be system-tested only by using the high-current injection test method. The internal electronics of these breakers can be checked out with test sets such as Cat. No. TAK-TS2, which is used with AKR-SST/ECS trips and with VersaTrip Mod. 2 or TVTS1 used with MicroVersaTrip. These sets are not suitable for making a *system* test, however.

High-current testing of GFP systems consists of injecting full-scale current into the equipment phase and neutral conductors to duplicate the flow of ground fault current under various conditions. The testing equipment required includes a high-current supply capable of delivering up to 1000 amperes or more at 2.5 volts, or similar. By using the lower ground fault current pickup settings on relays and breakers or switches, the current required to trip can be kept to a minimum, such as 300 or 400 amperes or less. If inspection authorities require tests at full GFP setting, a current supply capable of delivering 1200 amperes or more may be needed.

Connect the current supply as shown in the diagrams, using flexible welding cable such as No. 2 AWG. Also connect jumpers between the points indicated in the tables accompanying the diagrams.

GROUND FAULT PROTECTION IN THREE-WIRE EQUIPMENT

Ground fault protection can be provided for 3-wire and 4-wire equipment fed from a solidly grounded 4-wire supply, wye or delta. NEC Article 250-23(b) requires that whenever a service is derived from a grounded neutral system, the grounded neutral conductor must be brought into the service entrance equipment, and bonded to the equipment enclosure and ground bus, even if the grounded conductor is not needed for the load supplied by the service. This is required to provide a low-impedance ground fault current return path to the neutral to assure operation of the over-current device.

Test Diagrams For Systems With Ground Fault Relays

PAGE 5 THROUGH PAGE 12

FIGURE	DESCRIPTION
1	Main Breaker with G.F. Relay and Ground Return Sensor
2	Main Breaker with G.F. Relay and Zero-Sequence Sensor Arrangement
3	Main Breaker with G.F. Relay and Residual Sensor Arrangement
4	Feeder Breaker with G.F. Relay and Zero-Sequence Sensor Arrangement
5	Ground Fault Relay Protection on Normal and Emergency Main Breakers Interlocked for Automatic Throwover
6	Ground Fault Relay Protection on Normal and Emergency Main Breakers with Automatic Transfer Switch (3-pole)
7	Double-ended Substation — (Transformers not individually grounded) Single-point Ground and G.F. Relays
8	Double-ended Equipment — (both sources grounded) Modified Differential Scheme with G.F. relays.

Test Notes:

1. All tests are for 3-phase, 4-wire unless noted as 3-phase 3-wire.
2. Notes on diagrams referring to tripping at G.F. setting are intended to imply nominal values. Consistent tripping may require 125% of pickup settings, and good time-delay figures may be obtained only at 150% and higher.
3. **WARNING** In all the illustrations the source transformer(s) must be deenergized when applying and using the test current.
4. A temporary source of control power (usually 120 VAC) will be needed for operation of Ground-Break relays and shunt trip devices.
5. For information on the Ground-Break System, refer to publications GEI-86126 & GET-2964.

Test Diagrams

FIGURE 1
Main Breaker with G.F. Relay and Ground-Return Sensor

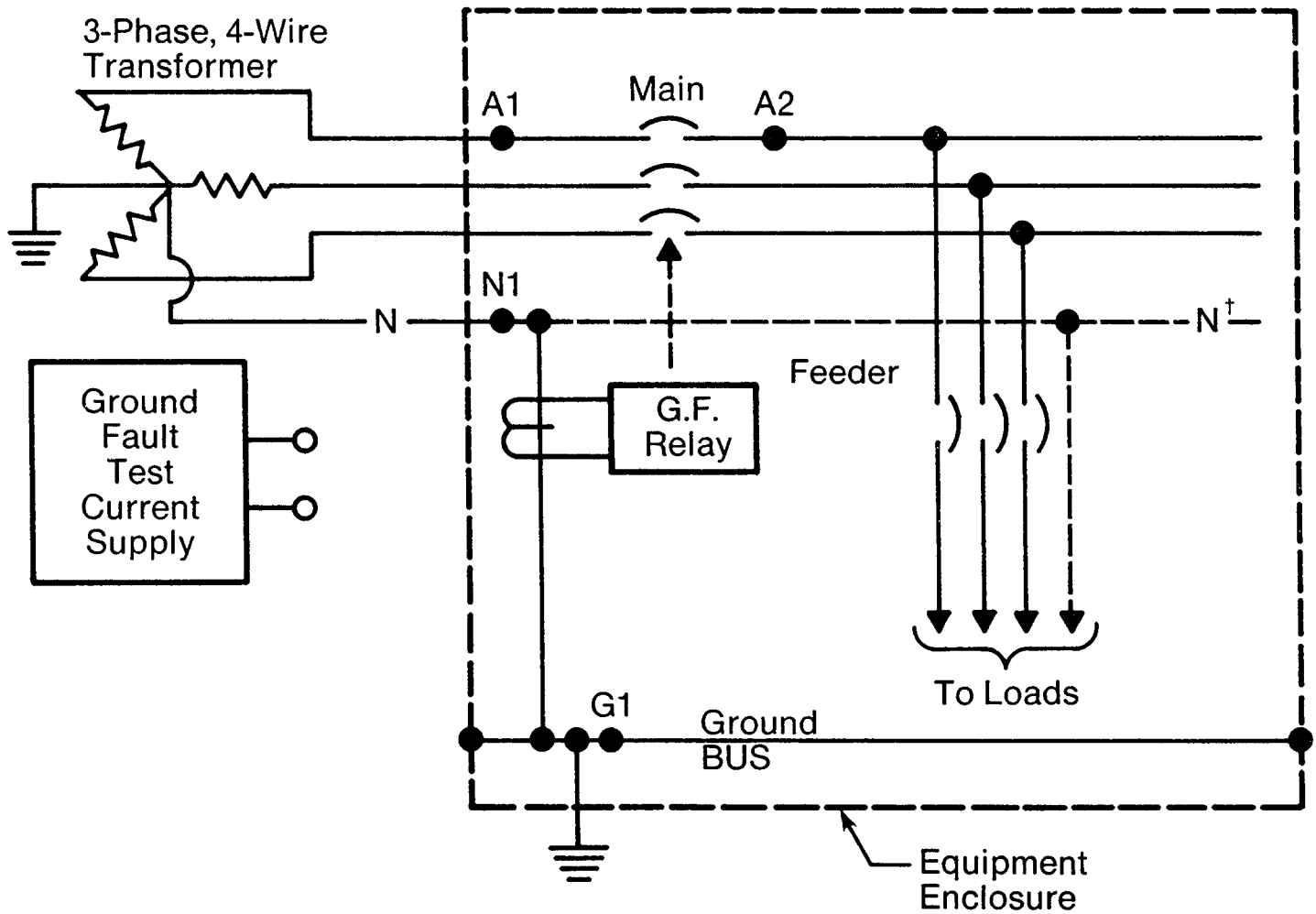

Test No.	Connect Test Current Supply to Points	Connect Jumper between Points	Results Expected	Comments
1-1	A1 and N1	A2-G1	Main breaker should trip	Confirms continuity of ground path from ground bus to neutral

† In 3-wire equipment the load neutral is not furnished.

FIGURE 2
Main Breaker with G.F. Relay and Zero-Sequence
Sensor Arrangement

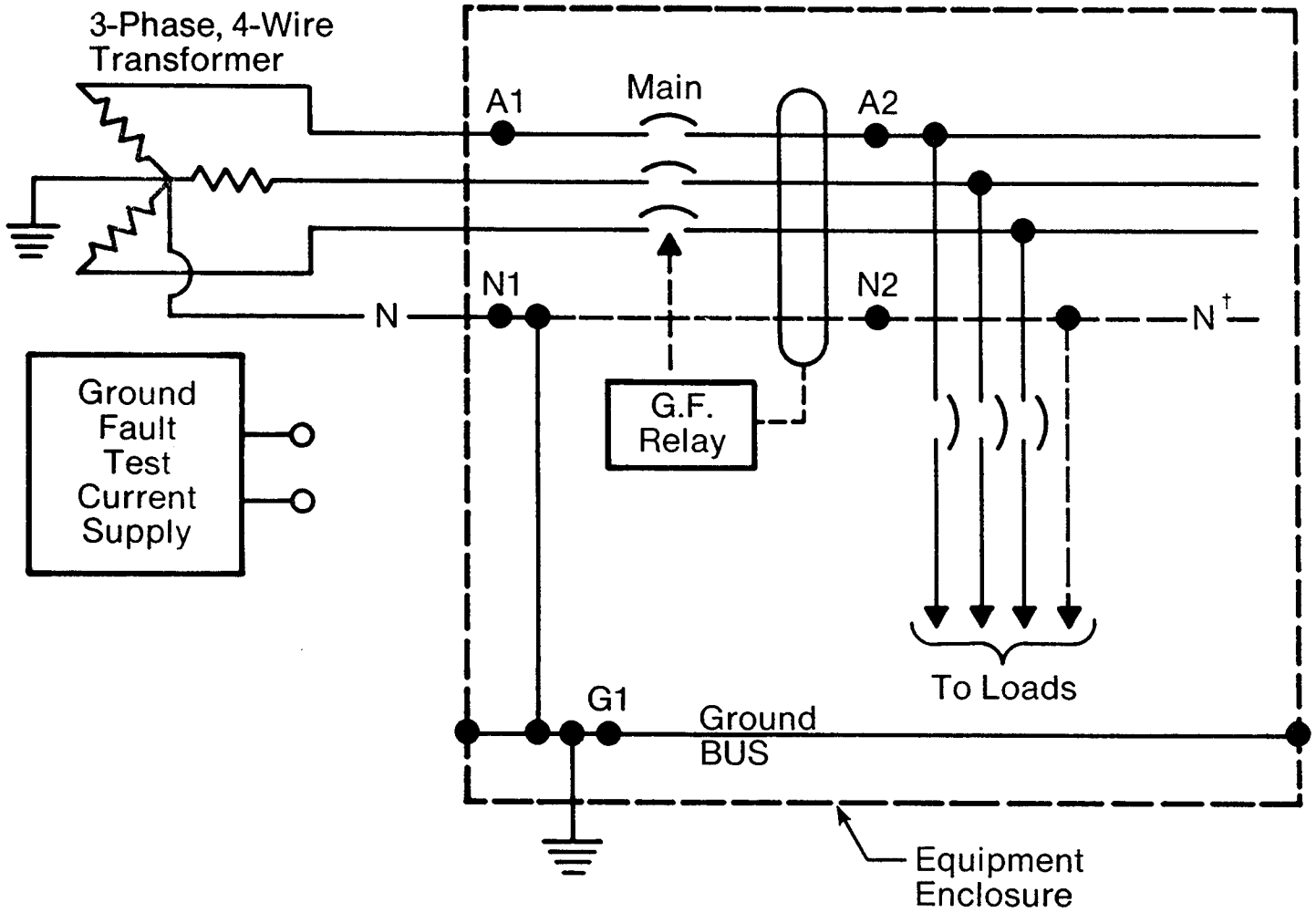

Test No.	Connect Test Current Supply to Points	Connect Jumper between Points	Results Expected	Comments
2-1	A1 and N1	A2-N2	Main breaker should <i>not</i> trip	Confirms that neutral and phase conductors go through sensor and in same direction
2-2	A1 and N1	A2-G1	Main breaker should trip	Confirms continuity of ground path from ground bus to neutral

NOTE: It is not necessary to repeat the tests for each phase if a visual inspection confirms that all phases go through the sensor window.

† In 3-wire equipment the load neutral is not furnished. Omit Test 2-1.

FIGURE 3
Main Breaker with G.F. Relay and Residual
Sensor Arrangement

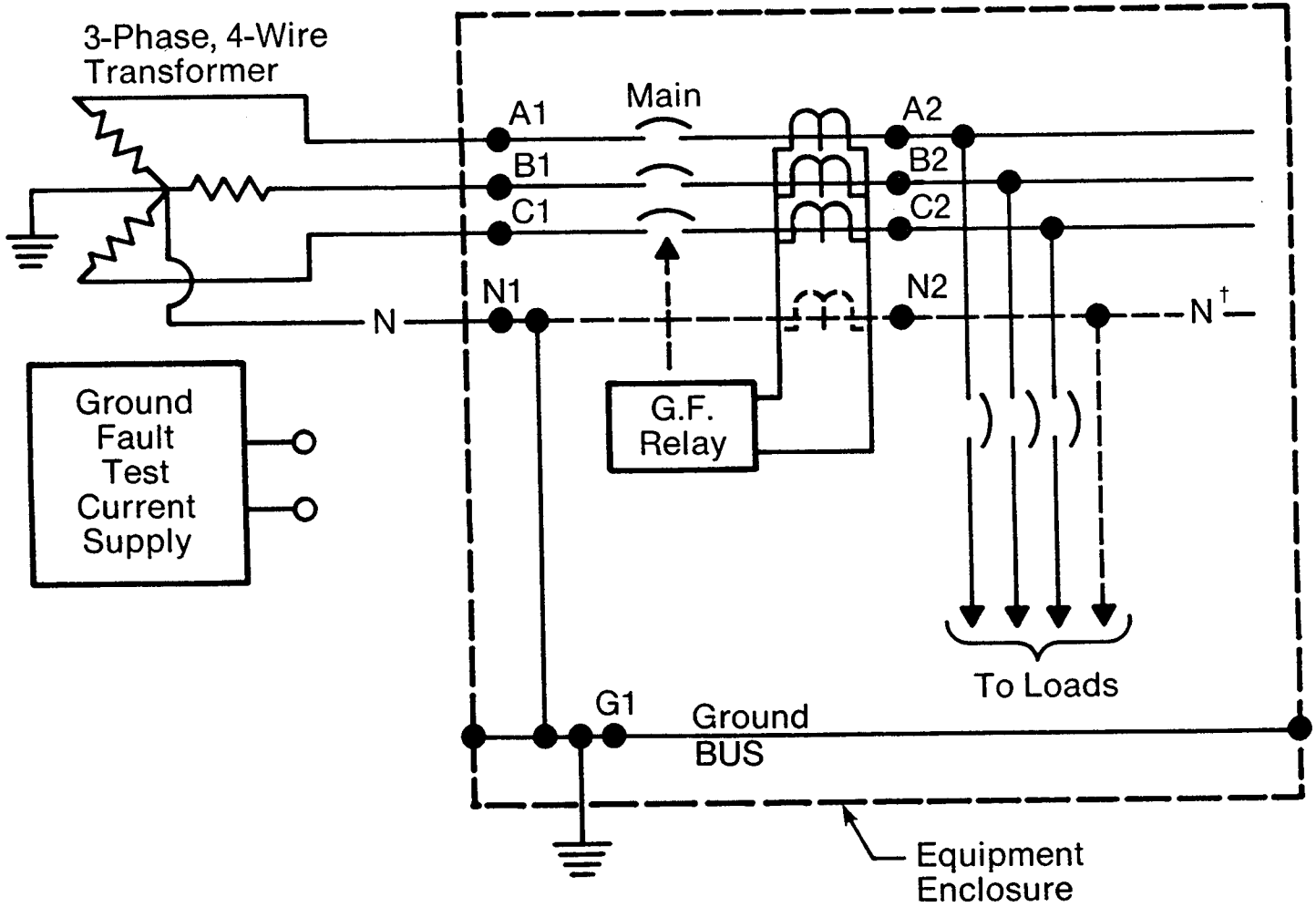

Test No.	Connect Test Current Supply to Points	Connect Jumper between Points	Results Expected	Comments
3-1	A1 and N1 B1 and N1 C1 and N1	A2-N2 B2-N2 C2-N2	Breaker should <i>not</i> trip.	Confirms correct polarity of sensor connections.
3-2	A1 and N1 B1 and N1 C1 and N1	A2-G1 B2-G1 C2-G1	Breaker should trip.	Confirms continuity of ground path from ground bus to neutral.

† In 3-wire equipment, the load neutral and neutral sensor are not furnished. Omit Test 3-1.

FIGURE 4
Feeder Breaker with G.F. Relay and Zero-Sequence Sensor Arrangement

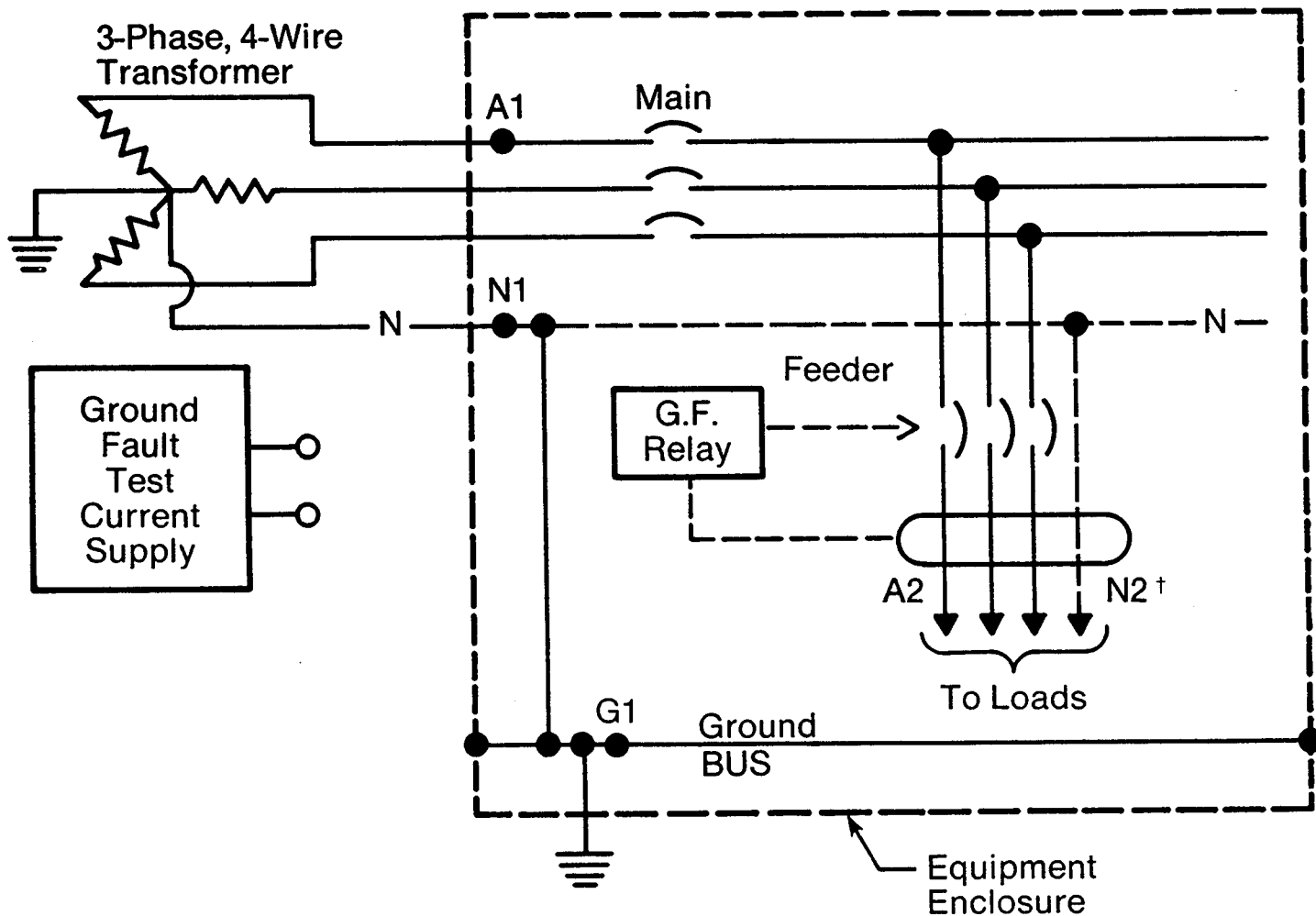

Test No.	Connect Test Current Supply to Points	Connect Jumper between Points	Results Expected	Comments
4-1	A1 and N1	A2-N2	Breaker should <i>not</i> trip.	Confirms correct polarity of sensor connections.
4-2	A1 and N1	A2-G1	Breaker should trip.	Confirms continuity of ground path from ground bus to neutral.

NOTE: It is not necessary to repeat the tests for each phase if a visual inspection confirms that all phases go through the sensor window.

† On 3-wire feeders, the neutral conductor is not furnished. Omit Test 4-1.

FIGURE 5

Ground Fault Relay Protection on Normal and Emergency Main Breakers Interlocked for Automatic Throwover on 3-Phase 4-Wire System

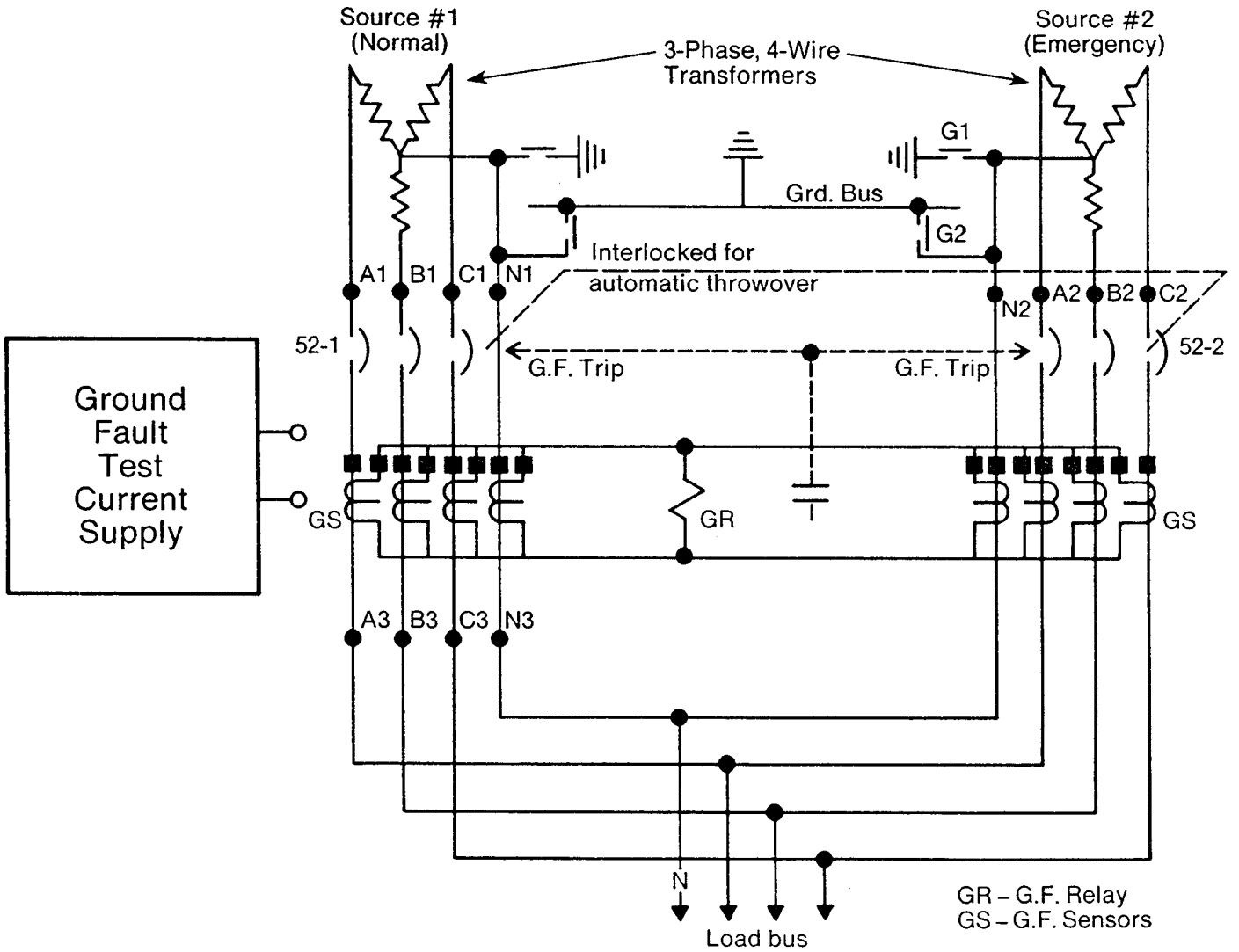

Test No.	Connect Test Current Supply to Points	Connect Jumper between Points	During the Test Disconnect Ground from Neutral at Points	Results Expected	Comments
5-1	A1 and N1 B1 and N1 C1 and N1	A3-N3 B3-N3 C3-N3	G1 and G2 G1 and G2 G1 and G2	Breaker 52-1 should not trip.	Confirms correct polarity of sensor connections.
5-2	A2 and N2 B2 and N2 C2 and N2	A3-N3 B3-N3 C3-N3	G1 and G2 G1 and G2 G1 and G2	Breaker 52-2 should not trip.	
5-3	A2 and N2 B2 and N2 C2 and N2	A3-N1 B3-N1 C3-N1	G1 and G2 G1 and G2 G1 and G2	Breaker 52-2 should trip.	Confirms operation when ground return path is through neutral from most distant ground.
5-4	A1 and N1 B1 and N1 C1 and N1	A3-N2 B3-N2 C3-N2	G1 and G2 G1 and G2 G1 and G2	Breaker 52-1 should trip.	

FIGURE 6

Ground Fault Relay Protection on Normal and Emergency Main Breakers with Automatic Transfer Switch (3-Pole) on 3-Phase 4-Wire System

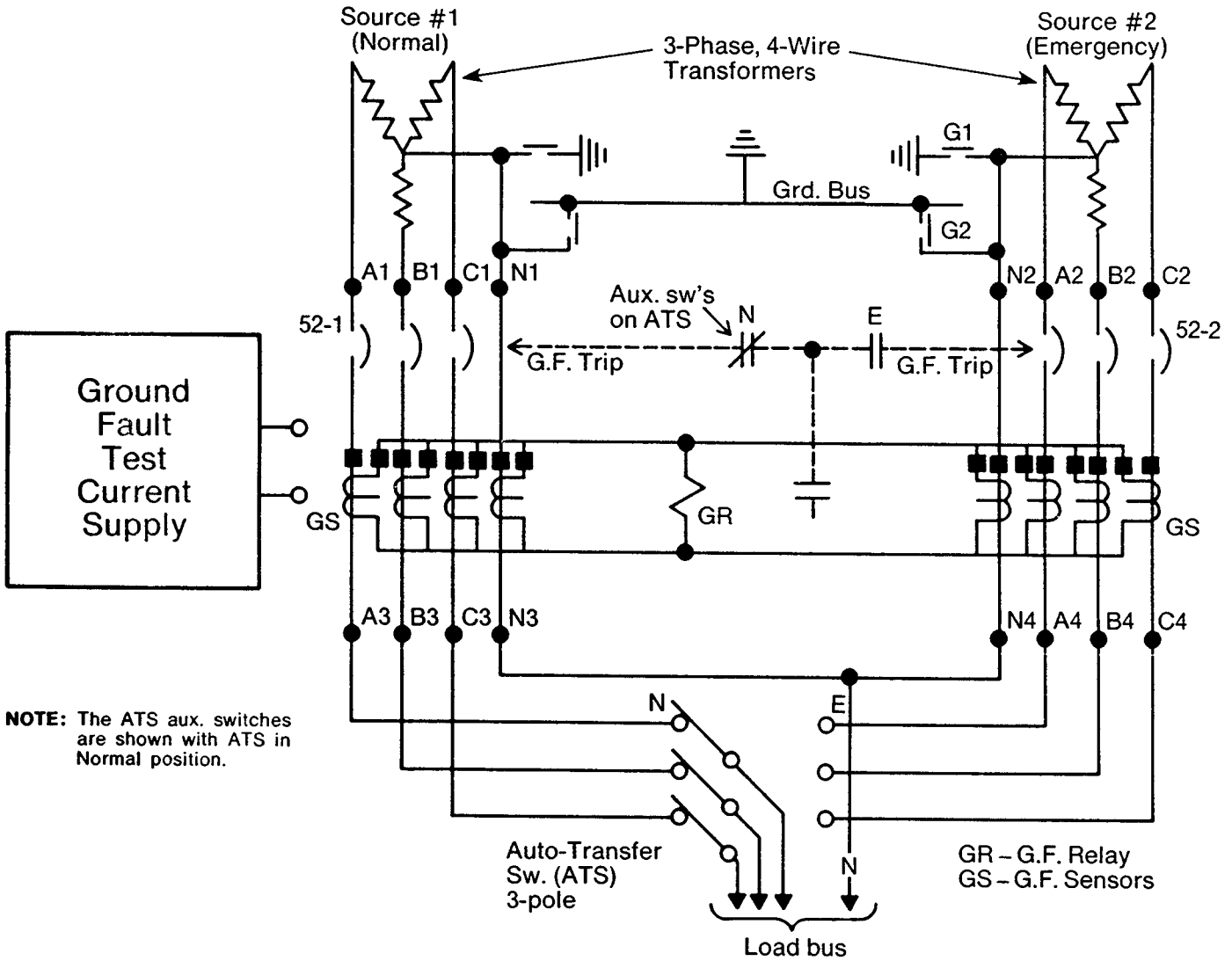

NOTE: The ATS aux. switches are shown with ATS in Normal position.

GR – G.F. Relay
GS – G.F. Sensors

Test No.	Transfer Switch Position	Connect Test Current Supply to Points	Connect Jumper between Points	During the Test Disconnect Ground from Neutral at these Points	Results Expected	Comments
6-1	N N N	A1 and N1 B1 and N1 C1 and N1	A3-N3 B3-N3 C3-N3	G1 and G2 G1 and G2 G1 and G2	Breaker 52-1 should not trip.	Confirms correct polarity of sensor connections.
6-2	E E E	A2 and N2 B2 and N2 C2 and N2	A4-N4 B4-N4 C4-N4	G1 and G2 G1 and G2 G1 and G2	Breaker 52-2 should not trip.	
6-3	E E E	A2 and N2 B2 and N2 C2 and N2	A4-N1 B4-N1 C4-N1	G1 and G2 G1 and G2 G1 and G2	Breaker 52-2 should trip.	Confirms operation when ground return path is through neutral from most distant ground.
6-4	N N N	A1 and N1 B1 and N1 C1 and N1	A3-N2 B3-N2 C3-N2	G1 and G2 G1 and G2 G1 and G2	Breaker 52-1 should trip.	

FIGURE 7

Double-Ended Substation (Transformers Not Individually Grounded) with Single-Point Ground and G.F. Relays on 3-Phase 4-Wire System

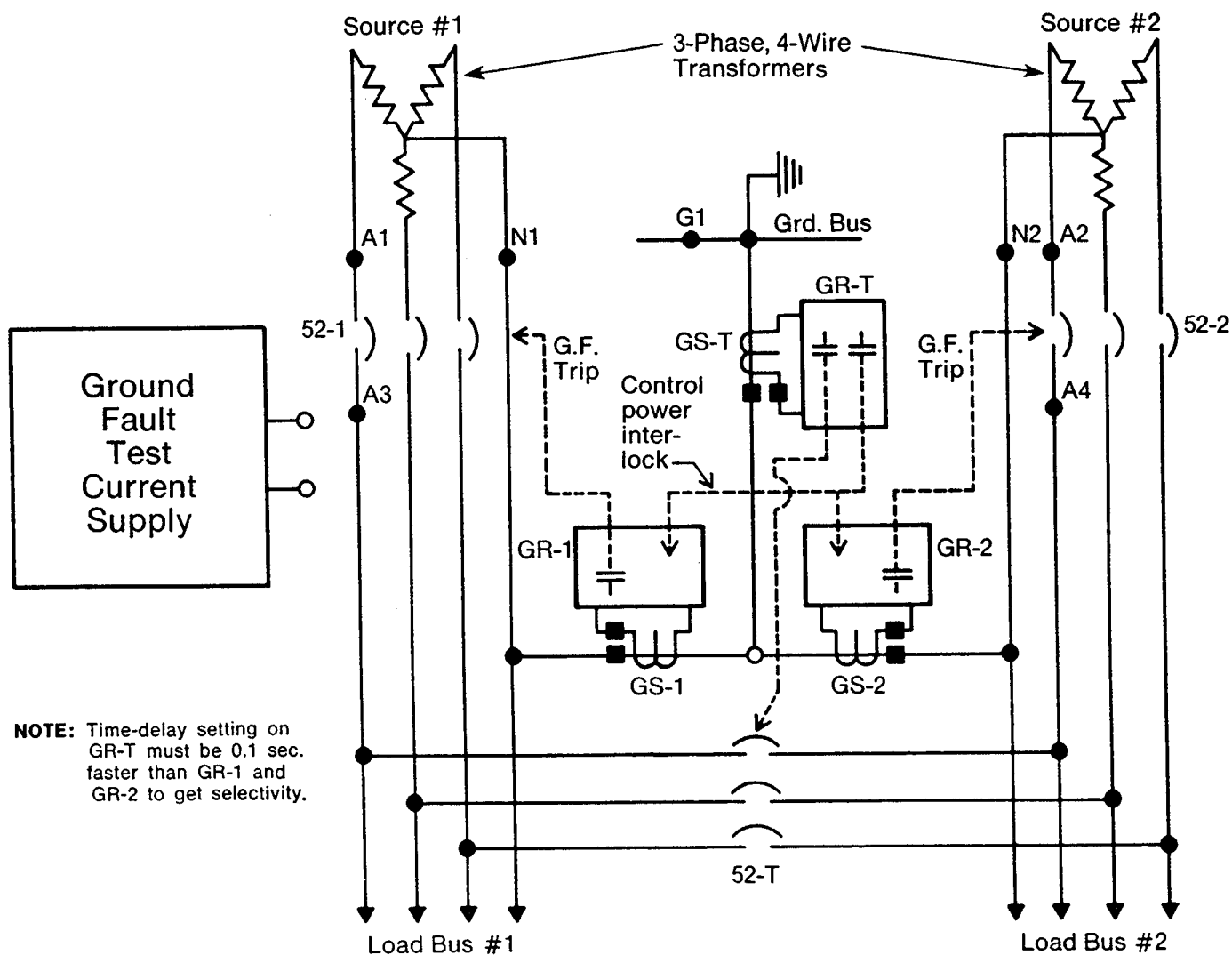

NOTE: Time-delay setting on GR-T must be 0.1 sec. faster than GR-1 and GR-2 to get selectivity.

Test No.	Connect Test Current Supply to Points	Connect Jumper between Points	Breakers Open or Closed			Results Expected	Comments
			52-1	52-T	52-2		
7-1	A1 and N1	A3-G1	c	o	c	Breaker 52-1 should trip.	52-1 trips for a G.F. on load bus #1.
7-2	A2 and N2	A4-G1	c	o	c	Breaker 52-2 should trip.	52-2 trips for a G.F. on load bus #2.
7-3	A2 and N2	A3-G1	o	c	c	Breaker 52-T should trip and Breaker 52-2 should not trip (see note).	52-T trips for a G.F. on load bus #1, fed from source #2.
7-4	A1 and N1	A4-G1	c	c	o	Breaker 52-T should trip and Breaker 52-1 should not trip (see note).	52-T trips for a G.F. on load bus #2, fed from source #1.

FIGURE 8

Double-Ended Equipment (Both Sources Grounded) using Modified Differential Scheme with G.F. Relays on 3-Phase 4-Wire System

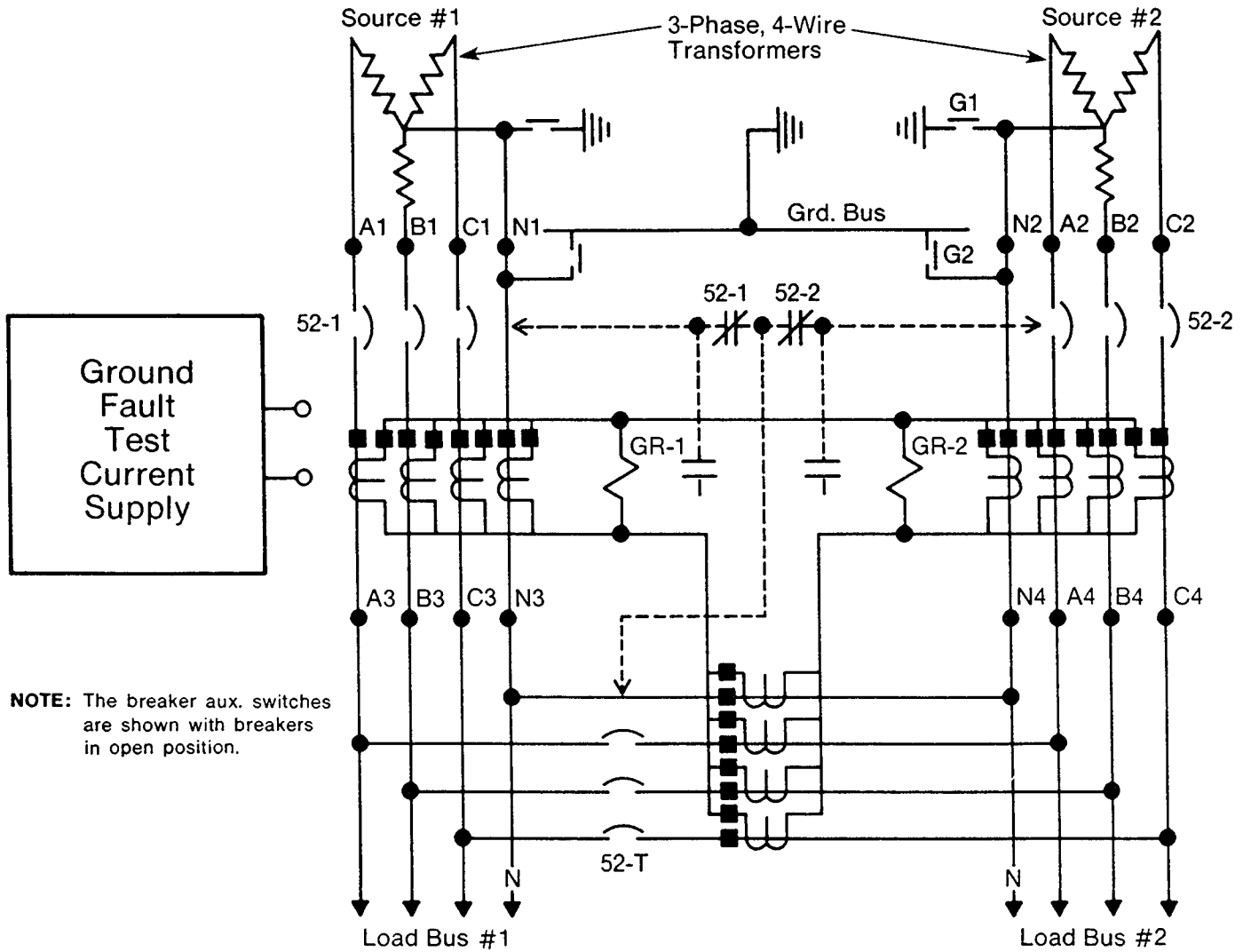

NOTE: The breaker aux. switches are shown with breakers in open position.

Test No.	Connect Test Current Supply to Points	Connect Jumper between Points	During the Test Disconnect Ground from Neutral at Points	Breakers Open or Closed			Results Expected	Comments
				52-1	52-T	52-2		
8-1	A1 and N1 B1 and N1 C1 and N1	A4-N4 B4-N4 C4-N4	G1 and G2 G1 and G2 G1 and G2	c c c	c c c	o o o	Breakers 52-1 and 52-T should not trip.	Confirms correct polarity of sensor connections.
8-2	A2 and N2 B2 and N2 C2 and N2	A4-N4 B4-N4 C4-N4	G1 and G2 G1 and G2 G1 and G2	o o o	c c c	c c c	Breaker 52-2 should not trip.	
8-3	A2 and N2 B2 and N2 C2 and N2	A4-N1 B4-N1 C4-N1	G1 and G2 G1 and G2 G1 and G2	o o o	c c c	c c c	Breaker 52-2 should trip.	52-2 trips for a G.F. on load bus #2.
8-4	A1 and N1 B1 and N1 C1 and N1	A3-N2 B3-N2 C3-N2	G1 and G2 G1 and G2 G1 and G2	c c c	c c c	o o o	Breaker 52-1 should trip.	52-1 trips for a G.F. on load bus #1.
8-5	A1 and N1 B1 and N1 C1 and N1	A4-N2 B4-N2 C4-N2	G1 and G2 G1 and G2 G1 and G2	c c c	c c c	o o o	Breaker 52-T should trip.	52-T trips for a G.F. on load bus #2.

Test Diagrams For Systems With Integral Ground Fault Protection

PAGE 13 THROUGH PAGE 16

FIGURE	DESCRIPTION
9	Neutral Sensor Polarity Markings
10	Main Breaker with Integral GFP
11	Feeder Breaker with Integral GFP
12	Integral GFP on Main and Tie Breakers of Double-ended Equipment — 3-Phase, 4-Wire

NEUTRAL SENSOR POLARITY MARKINGS

In the accompanying integral ground fault protection circuit diagrams the neutral sensors are depicted using conventional current transformer symbols. The equivalent polarity markings for VersaTrip, SelecTrip, SST and Micro VersaTrip integral trip sensors are shown in the figure below.

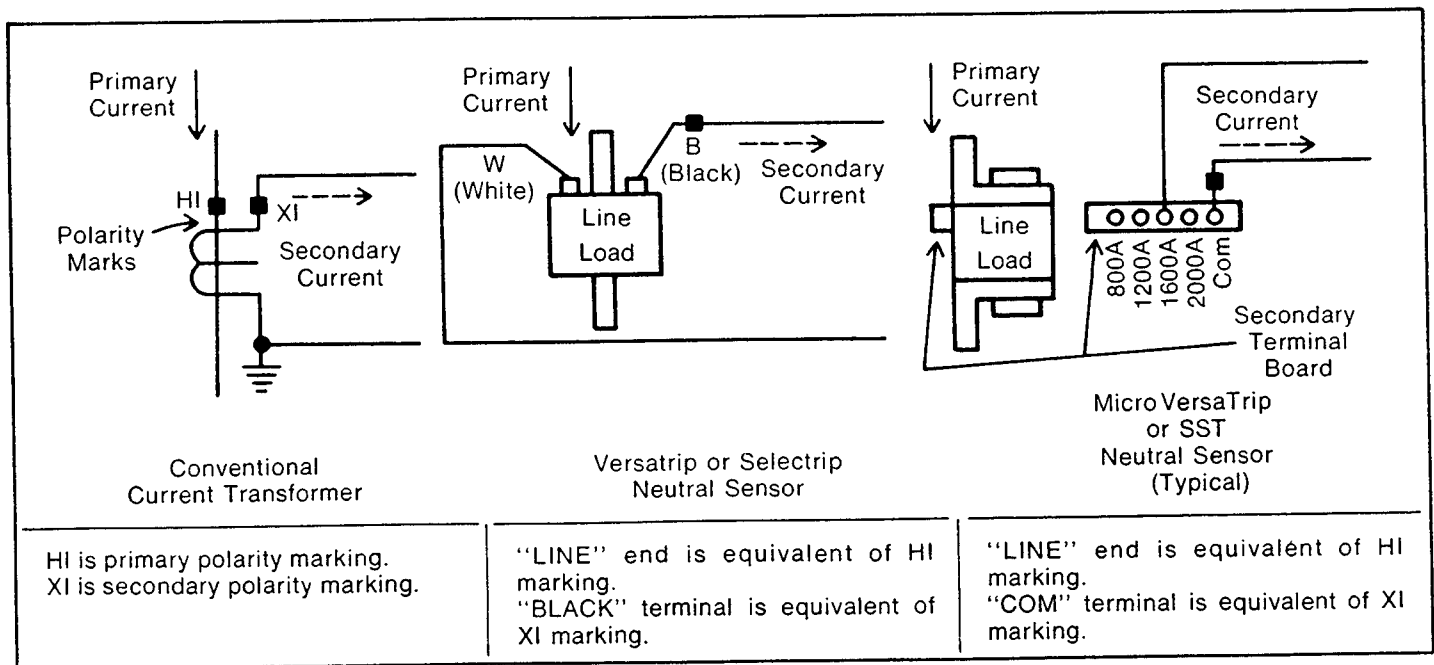

FIGURE 9

This diagram shows the equivalent polarity markings for neutral sensors that are not marked like conventional current transformers.

Note:

WARNING In all the illustrations the source transformer(s) must be deenergized when applying and using the test current.

Test Diagrams

FIGURE 10
Main Breaker with Integral Ground-Fault Protection —
3-Phase, 4-Wire

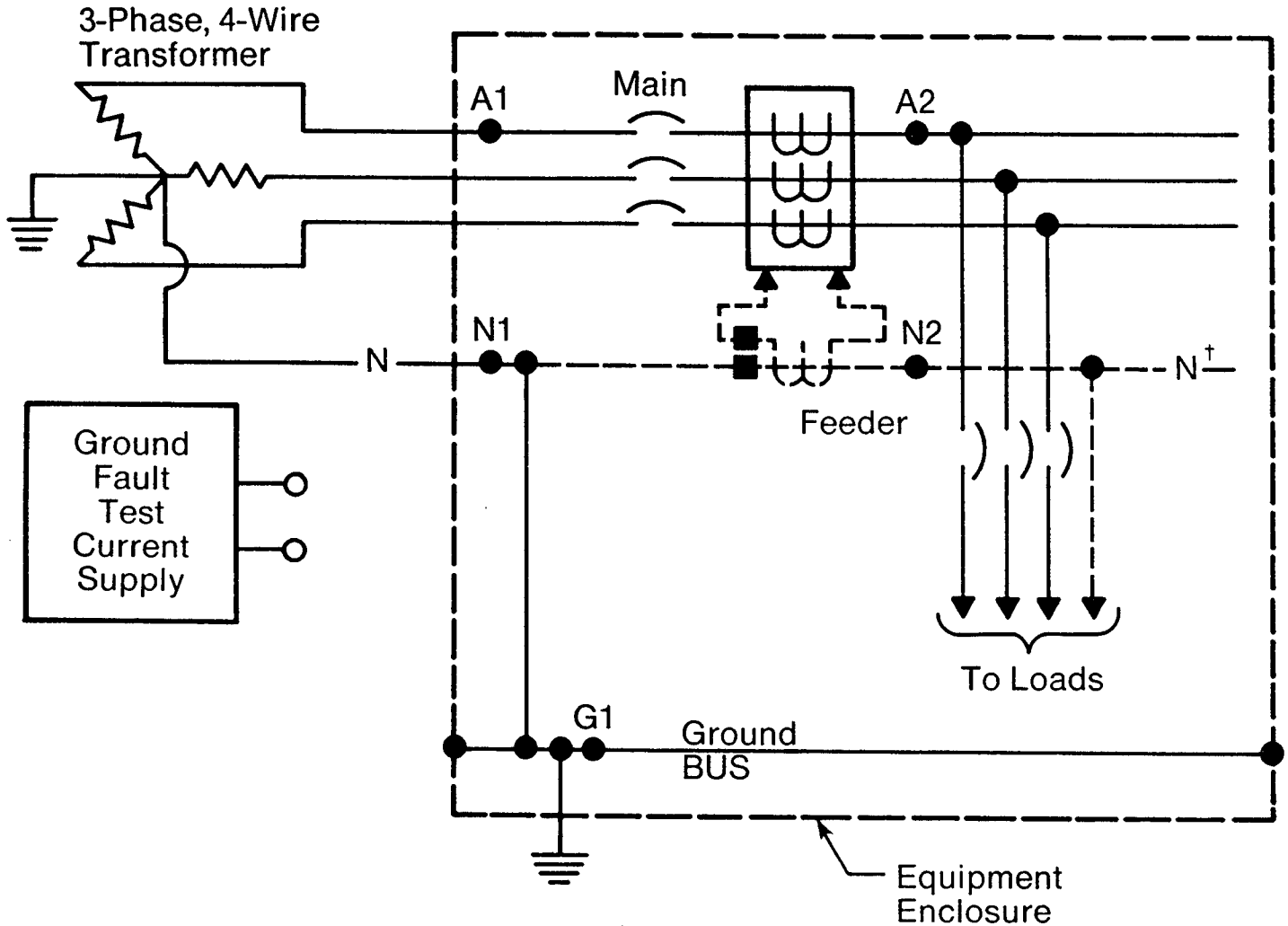

Test No.	Connect Test Current Supply to Points	Connect Jumper between Points	Results Expected	Comments
10-1	A1 and N1	A2-N2	Breaker should <i>not</i> trip.	This confirms that polarity and ampere rating of the neutral sensor match those of the phase sensors in the breaker.
10-2	A1 and N1	A2-G1	Breaker should trip at G.F. setting.	Confirms continuity of ground path from ground bus to neutral.

† In 3-wire equipment the load neutral is not furnished. Omit Test 10-1.

FIGURE 11
Feeder Breaker with Integral Ground-Fault Protection —
3-Phase, 4-Wire

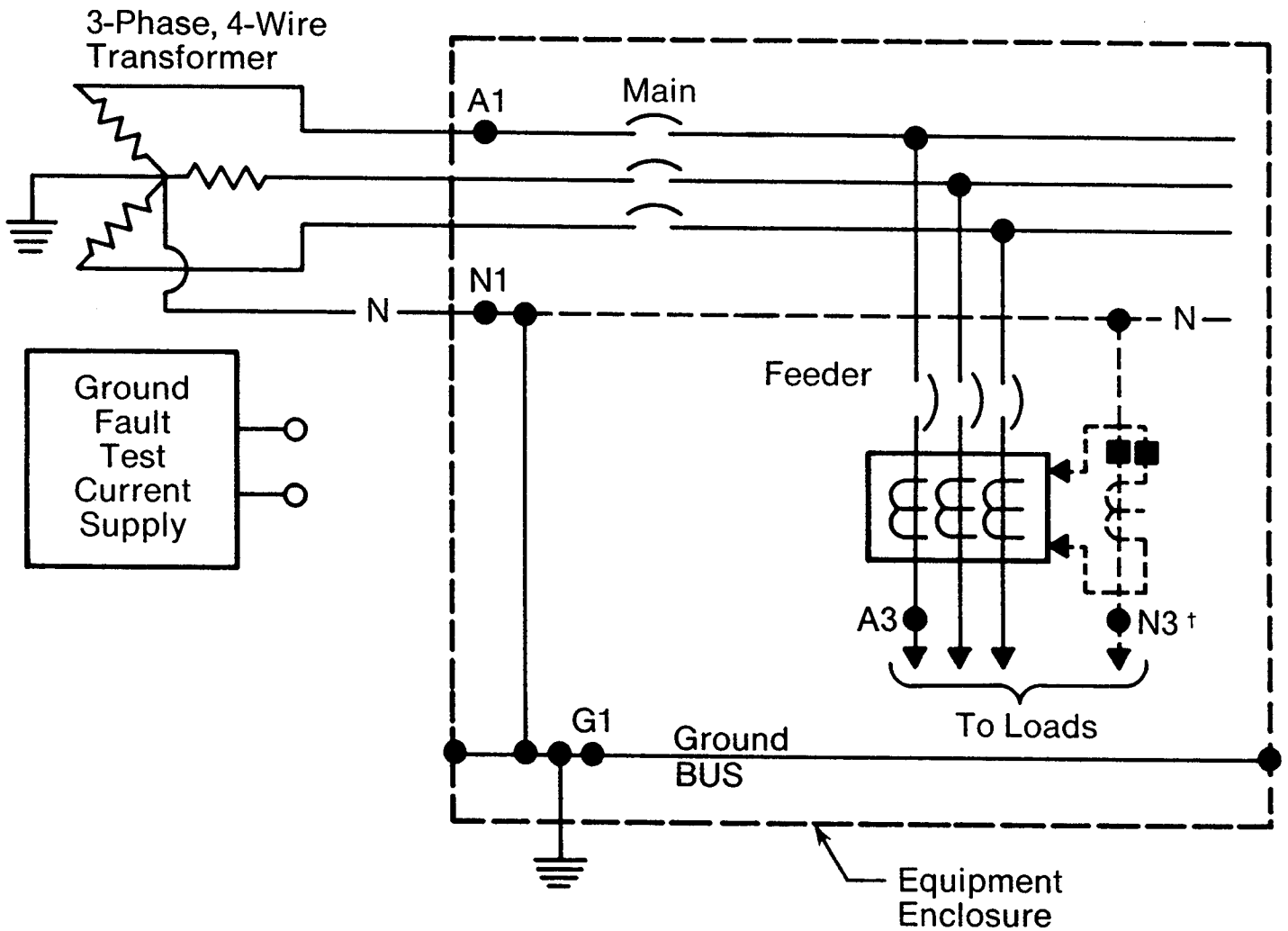

Test No.	Connect Test Current Supply to Points	Connect Jumper between Points	Results Expected	Comments
11-1	A1 and N1	A3-N3	Breaker should <i>not</i> trip.	This confirms that polarity and ampere rating of the neutral sensor match those of the phase sensors in the breaker.
11-2	A1 and N1	A3-G1	Breaker should trip at G.F. setting.	Confirms continuity of ground path from ground bus to neutral.

† On 3-wire feeders the neutral conductor and neutral sensor are not furnished. Omit Test 11-1.

FIGURE 12

Integral Ground Fault Protection on Main and Tie Breakers of Double-Ended Equipment — 3-Phase, 4-Wire

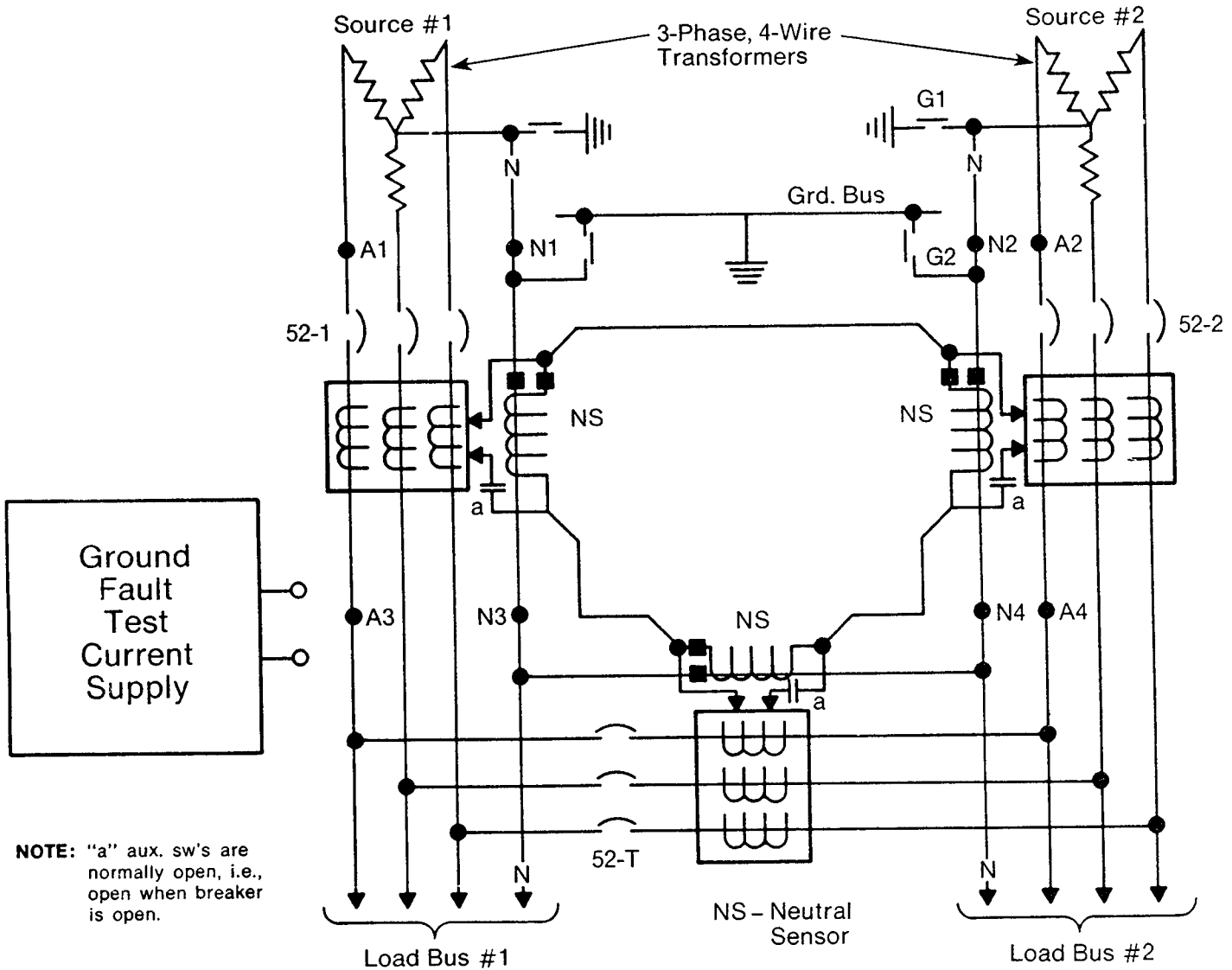

NOTE: "a" aux. sw's are normally open, i.e., open when breaker is open.

Test No.	Connect Test Current Supply to Points	Connect Jumper between Points	During the Test Disconnect Ground from Neutral at Points	Breakers Open or Closed			Results Expected	Comments
				52-1	52-T	52-2		
12-1	A1 and N1	A4-N4	G1 and G2	c	c	o	Breakers 52-1 and 52-T should not trip.	Confirms that sensor polarity is correct.
12-2	A2 and N2	A4-N4	G1 and G2	o	c	c	Breaker 52-2 should not trip.	
12-3	A2 and N2	A4-N1	G1 and G2	o	c	c	Breaker 52-2 should trip.	52-2 trips for a G.F. on load bus #2.
12-4	A1 and N1	A3-N2	G1 and G2	c	c	o	Breaker 52-1 should trip.	52-1 trips for a G.F. on load bus #1.
12-5	A1 and N1	A4-N2	G1 and G2	c	c	o	Breaker 52-T should trip.	52-T trips for a G.F. on load bus #2.

Ground Fault Protection With Ground Fault Relays PERFORMANCE TEST RECORD

This test form should be retained by those in charge of the building's electrical installation in order to be available to the authority having jurisdiction.

General Electric Order/Requisition No. _____

Customer Name _____

Location _____

Order No. _____

EQUIPMENT

- AV-Line Switchboard
- PowerBreak Switchboard
- AKD-6 L.V. Switchgear AKD-8 L.V. Switchgear
- Other _____

Rating: Volts _____ Phase _____ Wire _____
Amps. _____ Hz. _____

EQUIPMENT ARRANGEMENT

- Single-source
- Double-ended Other (explain) _____
- Unit-Substation Transformer(s) remote from equipment.

GROUND FAULT PROTECTION

Breaker (or switch) tripped by G.F. relay:

Function: Main Feeder; Circuit No. _____

Type _____ Drawout Stationary

Rating (Amps): Frame _____ Trip _____

GROUND FAULT RELAY & ACCESSORIES

- Ground-break System Other (explain) _____

Relay Cat. No. _____ Pickup Range (Amps) _____

Sensor (C.T.) Cat. No. _____

Monitor Panel (if used) Cat. No. _____

SENSOR ARRANGEMENT: Ground-return Type

- Residual (sensor on each phase).
- Zero-sequence (all conductors thru one window).
- Double-ended: Single-Point Ground Scheme Modified-Differential Scheme

Additional Description (if needed) _____

Ground Fault Protection With Ground Fault Relays

PERFORMANCE TEST RECORD

TEST RECORD

Test Number	G.F. RELAY SETTING		Test Current (Amps)	TRIPPING RESULTS	
	Pickup (Amps)	Delay (Sec.)		Bkr/Sw. Trip?	Measured Time For Bkr/Sw. to Open

CONCLUSIONS:

The test results are satisfactory. _____

The test results are not satisfactory. _____

(Explain) _____

Tests performed by: _____

Test Set Used: _____

Test Date: _____

Witnessed By: _____

Ground Fault Protection With Integral Ground Fault Trips On Circuit Breaker PERFORMANCE TEST RECORD

This test form should be retained by those in charge of the building's electrical installation in order to be available to the authority having jurisdiction.

General Electric Order/Requisition No. _____

Customer Name _____

Location _____

Order No. _____

EQUIPMENT

- AV-Line Switchboard
 PowerBreak Switchboard
 AKD-6 L.V. Switchgear AKD-8 L.V. Switchgear
 Other _____

Rating: Volts _____ Phase _____ Wire _____
 Amps. _____ Hz. _____

EQUIPMENT ARRANGEMENT

- Single-source
 Double-ended Other (explain) _____
 Unit-substation Transformer(s) remote from equipment.

GROUND FAULT PROTECTION

Breaker tripped by integral ground fault trips:

Function: Main Feeder; Circuit No. _____

Type _____ Drawout Stationary

Rating (Amps): Frame _____ Sensor/Tap _____

3-Wire _____ 4-Wire _____

Trip Type: SST VersaTrip SelecTrip MicroVersaTrip

Additional Description (if needed) _____

Ground Fault Protection With Integral Ground Fault Trips On Circuit Breaker PERFORMANCE TEST RECORD

TEST RECORD

Test Number	Ground Fault Settings		Test Current (Amps)	Tripping Results	
	Pickup in Mult. of Sensor Rating	Time Delay Band (min/int/max)		Bkr/Sw. Trip?	Measured Time For Bkr/Sw. to Open

CONCLUSIONS:

The test results are satisfactory. _____

The test results are not satisfactory. _____

(Explain) _____

Tests performed by: _____

Test Set Used: _____

Test Date: _____

Witnessed By: _____

Notes

For further information
call or write your local
General Electric
Sales Office or . . .

Distribution Equipment
Division
41 Woodford Avenue
Plainville, CT 06062

Outside the U.S. and Canada write Export Sales and Services,
570 Lexington Avenue, New York, NY 10022

GENERAL  **ELECTRIC**

OPTI-TRIP I RMS

APPLICATION NOTE OT-053090

OPTI-TRIP PICK-UP AND TIME BAND SETTINGS

OPTI-TRIP Model LSIG has seven (7) switches for pick-up and time band settings, the Model LSI has five (5).

The following abbreviations are used to identify the trip unit functions:

L = Long Time
S = Short Time
I = Instantaneous
G = Ground Fault

The following notations are used in the trip unit pick-up and time band settings:

X = Times CT Rating
S = Second Delay at 6x (For LT Time Band)
C = Cycles Delay (For GF and ST Time Band)
I²T = Ramp Function

The setting switches have discrete, positive detent positions. A small flat blade screwdriver is required to rotate the switches. The small groove along the switch shaft acts as the switch pointer. Changes to the switch settings can be made while the breaker is in service.

PICK-UP SETTINGS:

The pick-up setting in amps equals the CT current rating times the pick-up setting.

As an example, the primary pick-up currents for 600 amp CT's with the following settings are:

.25x GF pick-up times 600 amp = 150 amp
.5x LT pick-up times 600 amp = 300 amp
6x ST pick-up times 600 amp = 3600 amp
8x I pick-up times 600 amp = 4800 amp

The primary pick-up currents for 1600 amp CT's with the following settings are:

.5x GF pick-up times 1600 amp = 800 amp
1.0x LT pick-up times 1600 amp = 1600 amp
6x ST pick-up times 1600 amp = 9600 amp
10x I pick-up times 1600 amp = 16000 amp

TIME BAND SETTINGS:

The time band settings for LT, ST, and GF (I^2T on) are dependent only on the CT rating and not on the corresponding pick-up settings.

As an example:

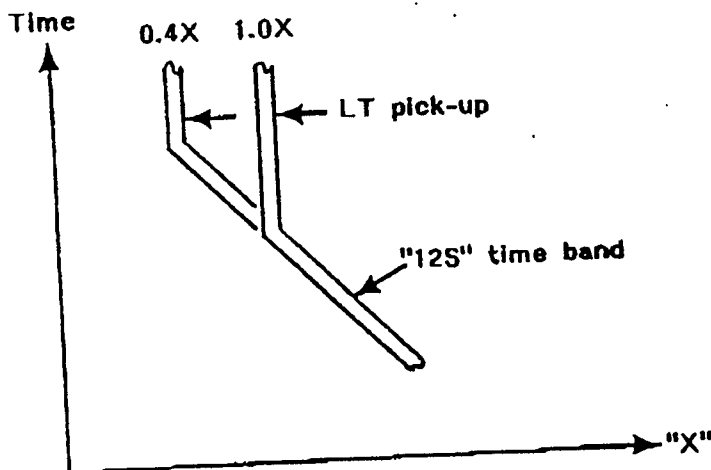

The proper LT pick-up setting is usually determined by the cable ampacity or the maximum continuous current capacity of the load as required by the NEC or local codes.

The proper time band settings are not so readily determined. A coordination study is usually required to select the time bands that best coordinate with the upstream protective device, as well as the largest down stream protective device.

For a motor load, the time band should allow for motor inrush and acceleration time and still provide locked rotor protection.

Normally, the lower pick-up values will require one of the shorter time bands, and the higher pick-up values will require one of the longer time bands.

TRIP TIME VALUES FOR TESTING:

To determine the LT, ST, and GF trips times for primary injection testing, the following may be helpful:

The trip times for LT, ST (I²T on) and GF (I²T on) are a function of:

- 1) Time Band Setting
- 2) CT Rating
- 3) Primary Test Current

Please note that once the proper time band is selected, the pick-up setting does not enter into the trip times. The only exception is that the primary test current must be at least 10% greater than the pick-up setting.

To find the trip time, it is first necessary to calculate the "X" equivalent of the primary test current and then determine the time by calculation, or by using the time-current trip curves.

The "X" value is equal to the primary test current divided by the CT rating.

$$X = \frac{\text{Primary Test Current}}{\text{CT Rating}}$$

As an example, the "X" value for the following primary test currents and 1600 amp CT's are:

$$\begin{aligned} 2400 \text{ Amp Primary Test Current, } X &= 2400/1600 = 1.5 \\ 4800 \text{ Amp Primary Test Current, } X &= 4800/1600 = 3.0 \\ 9600 \text{ Amp Primary Test Current, } X &= 9600/1600 = 6.0 \end{aligned}$$

For an 800 amp CT with the following primary test currents, the "X" values are:

$$\begin{aligned} 600 \text{ Amp Primary Test Current, } X &= 600/800 = 0.75 \\ 2400 \text{ Amp Primary Test Current, } X &= 2400/800 = 3.0 \\ 4800 \text{ Amp Primary Test Current, } X &= 4800/800 = 6.0 \end{aligned}$$

Once the "X" value of the primary test current is determined, the trip time can be determined graphically from the time-current trip curves as follows:

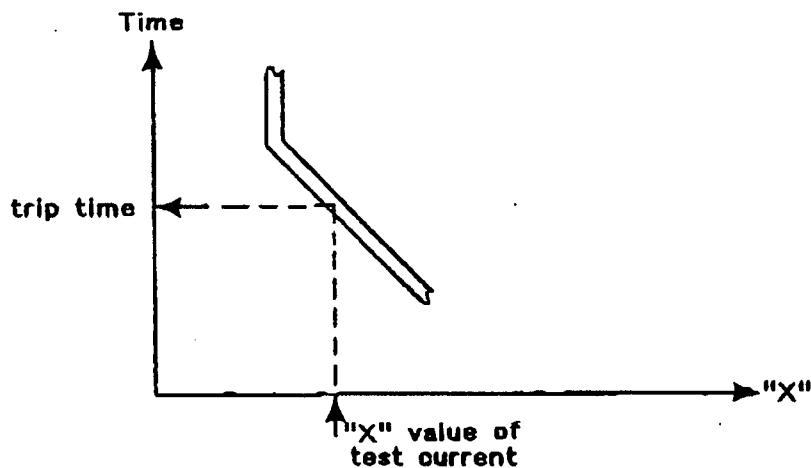

The trip times can also be determined by calculation using the following equation:

$$T \text{ (sec)} = \frac{\text{Time Band Constant}}{(X)^2}$$

The time band constants are:

GF I²T: 6C TIME BAND CONSTANT = 0.10
 12C TIME BAND CONSTANT = 0.20
 24C TIME BAND CONSTANT = 0.40
 48C TIME BAND CONSTANT = 0.80

ST I²T: 6C TIME BAND CONSTANT = 10.0
 12C TIME BAND CONSTANT = 20.0
 24C TIME BAND CONSTANT = 40.0
 48C TIME BAND CONSTANT = 80.0

LT: 3S TIME BAND CONSTANT = 108.
 4.25S TIME BAND CONSTANT = 153.
 6S TIME BAND CONSTANT = 216.
 8.5S TIME BAND CONSTANT = 306.
 12S TIME BAND CONSTANT = 432.
 17S TIME BAND CONSTANT = 612.
 24S TIME BAND CONSTANT = 864.
 34S TIME BAND CONSTANT = 1224.

As an example, the trip times for a 1600 amp CT with the following primary currents and time bands are:

6S LT Time Band, 3200 Amp Primary Current:

$$X = \frac{3200}{1600} = 2 \quad ; \quad T = \frac{216}{(2)^2} = 54 \text{ sec.}$$

12S LT Time Band, 4800 Amp Primary Current:

$$X = \frac{4800}{1600} = 3 \quad ; \quad T = \frac{430}{(3)^2} = 48 \text{ sec.}$$

24C ST Time Band, 9600 Amp Primary Current:

$$X = \frac{9600}{1600} = 6 \quad ; \quad T = \frac{40.0}{(6)^2} = 1.11 \text{ sec.}$$

6C GF Time Band, 6400 Amp Primary Current:

$$X = \frac{640}{1600} = 0.4 \quad ; \quad T = \frac{0.10}{(0.4)^2} = 0.625 \text{ sec.}$$

The above trip times are for the center of the time band. The tolerance for the trip unit is $\pm 10\%$ in the current direction. This corresponds to $\pm 23\%$ in the time direction.

OPTI-TRIP II™ RMS

CIRCUIT BREAKER TRIP UNIT WITH ADVANCED MICRO-CONTROLLER INTELLIGENCE

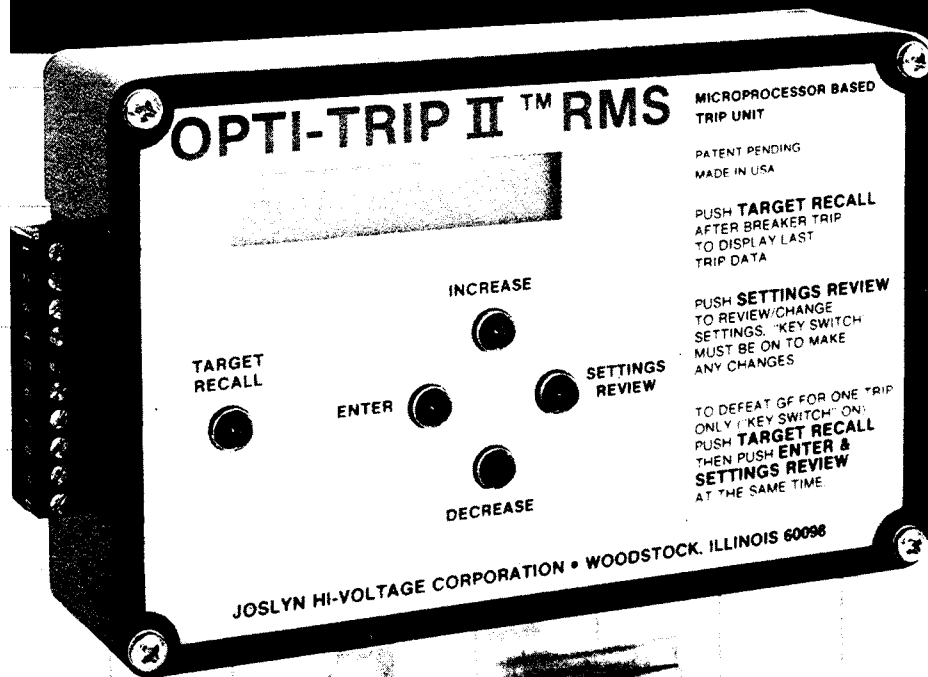

ADVANTAGES:

- True RMS current sensing.
- Displays last trip data on request.
- Alarm relay.
- All settings made in amps or seconds.
- Retrofit kits for most manufacturer's breakers.

OPTIONS:

- 16 character display showing actual 3-phase and ground currents.
- Future communication capabilities.

You asked and we listened. The result — the new Opti-Trip II RMS, a new concept in circuit breaker trip units that incorporates a veritable customer wish list of features.

The "user friendly" design makes inputting the settings easier than ever. The compact one piece trip unit with plug-in wiring makes installation quick and simple.

JOSLYN

HI-VOLTAGE CORPORATION

P.O. BOX 1189, WOODSTOCK, ILLINOIS 60098
PHONE: (815) 338-6060 FAX: (815) 338-8715

OPTI-TRIP II™ RMS

FEATURES

- True RMS current sensing for overloads and fault currents provided by the latest in digital micro-controller technology.
- 16 Character Display for ease in making/reviewing the trip unit settings.
- Optional Ammeter Feature using the 16 Character Display for the breaker 3-phase and ground fault currents.
- The Last Trip Display is activated by pushing the "Target Recall" button and provides the reason for the last trip along with the 3-phase and ground fault currents at the time of trip.
- Security System reduces the risk of tampering with the trip unit settings.
- Ease of Coordination due to the digital design that allows settings to be made in extremely small increments. Settings are saved in a non-volatile EEPROM memory and can easily be changed.
- Available with LSI or with LSIG Functions. (Long time, Short time, Instantaneous, Ground fault)
- Standard Alarm Relay with form "C" contacts.
- Tapped Current Transformers are standard allowing an extended range of settings. Changing the tap is quick and easy by using the pull-apart terminal blocks.
- A Plug-In Wiring Harness significantly reduces the installation time and eliminates wiring errors.
- Kits available for many breakers complete with bus work (as required), current transformers, actuator (manual or automatic reset), brackets, hardware, wiring harness and installation instructions.
- Self Powered from the specially designed signal current transformers.
- Rugged and Dependable due to:
 - * 150° F ambient temperature rating. (85° C rated electronic integrated circuits)
 - * Conformal coated circuit boards for added environmental protection.
 - * Rugged extruded aluminum housing.
 - * One week burn-in of each unit at 150° F and 90% load to greatly reduce the risk of "infant mortality" failure.
- Completely designed and manufactured in the United States.
- Conditional 2-Year Warranty because of the quality of design, construction, burn-in and extensive testing that each trip unit undergoes.
- Most Important of All . . .*
Customer Service and Satisfaction is our primary goal.

When first installed, commissioning is easy as 1 ... 2 ... 3

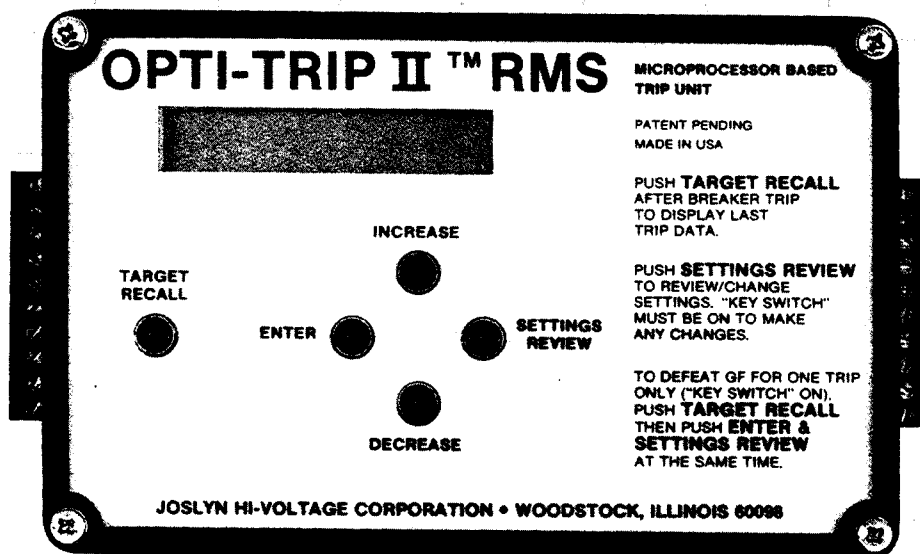

STEP 1

Power-Up the Unit
by pressing the "Target Recall" button.

STEP 2

Make the Settings
by pressing the "Settings Review" button with the "Security Key" closed (see instruction manual).
The trip unit will display the model and serial number and then lead the user through each of the settings step by step.
For each setting, the "increase" or "decrease" buttons are pressed until the correct value appears on the display. The "Enter" button is then pressed.

STEP 3

Review/Save the Settings
after the last setting is made.
The display will ask if the settings are correct or if a review is desired.
All the settings will be securely saved in EEPROM memory which does not require battery power to remain intact.
When correct, the "Enter" button is pressed, the "Security Key" is removed and . . .
Opti-Trip II RMS is ready for service.

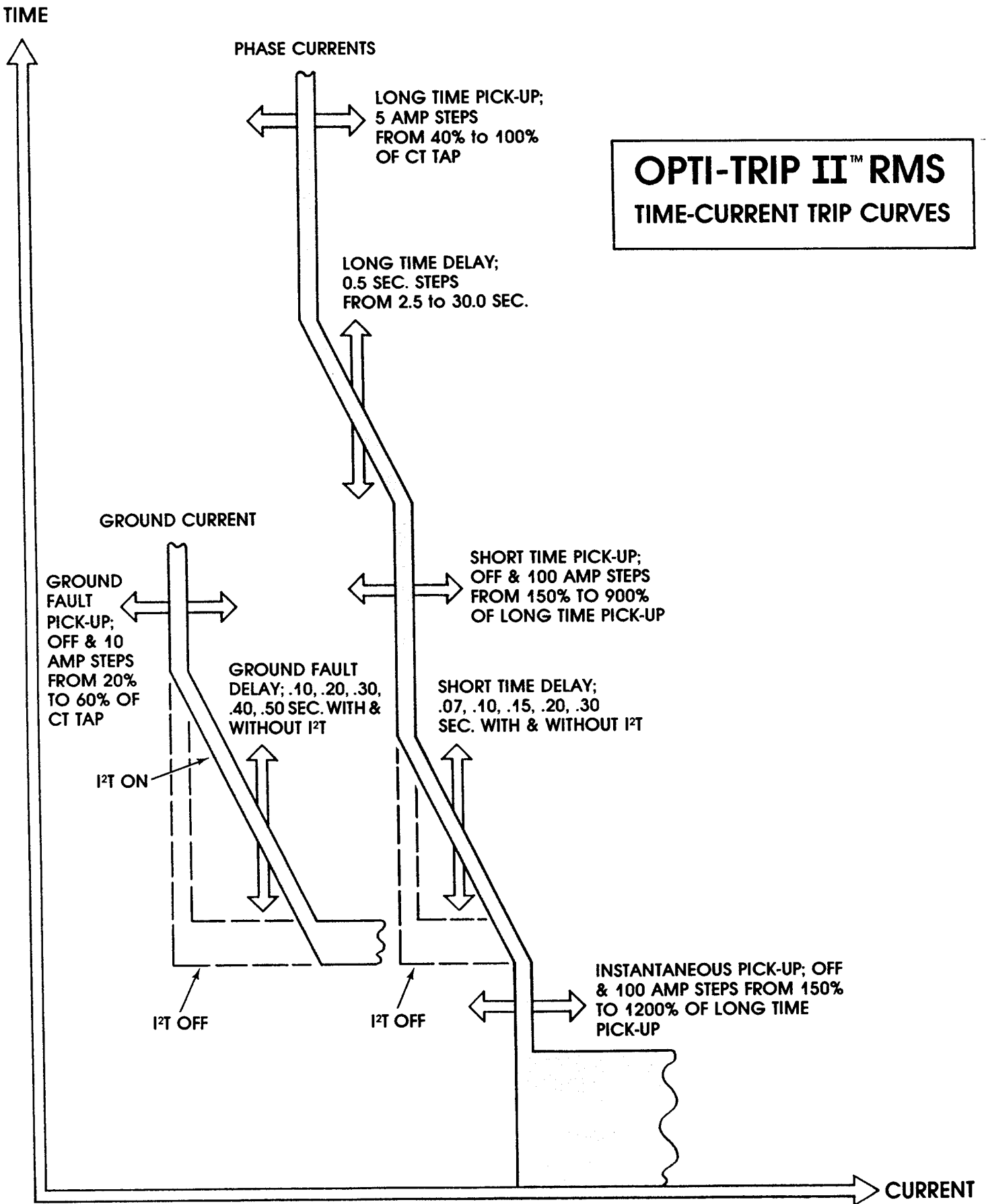

To find out how Opti-Trip II RMS can deliver the kind of performance you require, contact your local electrical equipment service firm:



Joslyn Hi-Voltage Corporation

Opti-Trip II RMS™
Instruction Manual

Joslyn Hi-Voltage Corporation
4000 East 116th Street
Cleveland, Ohio 44105
USA

Tel: (216) 271-6600
Fax: (216) 341-3615

I223-0001
Rev. #0 3/31/94

Table Of Contents

1.0	Introduction	Page	5
1.1	Options		5
1.2	Model Designations		6
2.0	Features		7
2.1	True RMS Current Sensing		7
2.2	Ground Fault Filter		8
2.3	16 Character Display		8
2.4	Display Last Trip Data		9
2.5	Current Transformers		10
2.6	Actuator		11
2.7	Battery		11
2.8	Neutral Current Transformer		12
3.0	External Connections		13
3.1	Breaker Wiring Harness (Right Side of Trip Unit)		13
3.2	Auxiliary Connection (Lower Left Side of Trip Unit)		14
3.3	Auxiliary Power (Upper Left Side of Trip Unit)		14
4.0	Security Key		15
5.0	Commissioning		15
5.1	Power-Up the Trip Unit		16
5.2	Security Key		17
5.3	CT Tap Setting		17
5.4	LT Pick-Up Setting		18
5.5	LT Delay Setting		18
5.6	ST Pick-Up Setting		19
5.7	ST Delay Setting		19
5.8	ST I ² T		20
5.9	I Pick-Up Setting		21
5.10	GF Pick-Up Setting		22
5.11	GF Delay Setting		23
5.12	GF I ² T		23
5.13	Exit Procedure		24
6.0	Changing Settings		25
7.0	Target Recall		26
8.0	Normal Operation		29
9.0	Alarm Relay		29

10.0	Testing	Page	30
10.1	Step 1: Commission the Trip Unit		30
10.2	Step 2: Defeat GF		30
10.3	Step 3: Check Power-Up and Verify Proper CT Setting		31
10.4	Step 4: Primary Injection Tests		32
10.5	Step 5: Erase Last Trip Data		32
11.0	Communications (Future)		33
12.0	Ratings		33
13.0	Warranty		34
14.0	Time-Current Curve		34
14.1	LT Trip Time		35
14.2	ST Trip Time		36
14.3	GF Trip Time		37
15.0	Figures		
15.1	External Wiring		39
15.2	External Connections		41
15.3	Time-Current Trip Curves		43

Opti-Trip II RMS, Instruction Manual

1.0 Introduction

Opti-Trip II RMS is a state of the art, micro-controller based trip unit intended for use on 600 Volt class circuit breakers.

The trip unit is a digital design using a Motorola HC711E9, 8-bit micro-controller and a 16 character liquid crystal display (LCD).

The trip unit provides 3-phase over-current and fault protection. Ground over-current protection is also available on some models.

The trip unit is "direct acting" since it does not require an external power source to perform it's protection function. Power is taken directly from the currents the trip unit is monitoring by way of a set of current transformers (CTs).

Every effort was made to design and produce a reliable, accurate and "user friendly" trip unit.

****** IMPORTANT ******

The trip unit will NOT FUNCTION as it is shipped from the factory. The user must first COMMISSION the unit as outlined in section 5.0 to make it functional.

As part of the manufacturing quality control, each trip unit is "burned in" under load for a nominal 7 day period at 150°F ambient.

1.1 Options

The following options are available:

- a) Ammeter display.
- b) Ground fault protection for 3-phase, 3-wire or 4-wire systems.
- c) Communications.
- d) 25Hz and 50Hz units.

1.2 Model Designation

The first two digits of the trip unit serial number contains the model number designation as follows:

Model #	Trip Functions	Ammeter Option	Frequency	Communications Option
00XXXXX	LSI	No	60Hz	No
01XXXXX	LSIG	No	60Hz	No
04XXXXX	LSI	Yes	60Hz	No
05XXXXX	LSIG	Yes	60Hz	No
10XXXXX	LSI	No	50Hz	No
11XXXXX	LSIG	No	50Hz	No
14XXXXX	LSI	Yes	50Hz	No
15XXXXX	LSIG	Yes	50Hz	No
20XXXXX	LSI	No	25Hz	No
21XXXXX	LSIG	No	25Hz	No
24XXXXX	LSI	Yes	25Hz	No
25XXXXX	LSIG	Yes	25Hz	No
40XXXXX	LSI	No	60Hz	Yes
41XXXXX	LSIG	No	60Hz	Yes
44XXXXX	LSI	Yes	60Hz	Yes
45XXXXX	LSIG	Yes	60Hz	Yes
50XXXXX	LSI	No	50Hz	Yes
51XXXXX	LSIG	No	50Hz	Yes
54XXXXX	LSI	Yes	50Hz	Yes
55XXXXX	LSIG	Yes	50Hz	Yes

"XXXXX" contains the unique serial number as well as the date of manufacture code.

2.0 Features

Opti-Trip II RMS offers the following features:

- a) True RMS current sensing.
- b) Displays last trip data.
- c) All settings are made directly in amps or in seconds.
- d) An alarm relay is standard.
- e) Security system.
- f) Ease of coordination is provided with settings that are made in extremely small increments.
- g) Plug-in wiring harness to reduce installation time and eliminate wiring errors.
- h) 16 Character display.
- i) Small package.

2.1 True RMS Current Sensing

Opti-Trip II RMS uses one of the latest Motorola micro-controller chips available to perform the RMS calculations and to implement the logic functions.

Each of the three phase currents and the ground current (if applicable) is sampled at a 0.463 milli-second rate during the sample period. For each sample period, the micro-controller performs the RMS calculation by squaring the current samples, summing the square values and then taking the square root of the resultant sum. This value is then multiplied by the current transformer tap rating to arrive at the current in amps.

The RMS calculation is performed individually for each phase and for the ground fault current (if applicable).

2.2 Ground Fault Filtering

For those units equipped with the GF feature, a 60Hz (50Hz or 25Hz as applicable) band-pass filter is incorporated in the GF circuit.

The band-pass filter is intended to reduce the possibility of nuisance GF trips due to the presence of 3rd harmonic currents (or multiples of the 3rd harmonic). The 3rd harmonic currents can indicate a GF when in reality none exists.

2.3 16 Character Display

A 16 character dot matrix liquid crystal display (LCD) is the interface between the trip unit and the user.

The dot matrix LCD is extremely versatile because it is capable of displaying not only numbers but also letters and symbols.

The LCD is used for the following purposes:

- 1) Entering the CT tap rating and making the pick-up and time delay settings with prompts from the display.
- 2) Displaying on demand, the CT tap rating and the various pick-up and delay settings.
- 3) Displaying on demand the reason for the last trip along with the phase and ground (if applicable) currents at the time of trip.
- 4) Displaying the breaker phase and ground currents (if applicable) under normal operation.

****** NOTE ******

With the LCD and just a few push buttons, an extremely large number of settings can be accessed.

The LCD has a low level backlight that can be activated by holding in the "TARGET RECALL" push button. This feature is useful in low ambient light conditions.

2.4 Display Last Trip Data

After a breaker trip, the trip unit will save the trip data in a non-volatile EEPROM memory. The last trip data is then displayed for 30 seconds after the trip and it can be recalled later. This data is written over with the data from the next trip event.

The last trip data consists of the type of trip (ie., LT, ST, I or GF as applicable) and the phase currents and ground current (if applicable) at the time of trip.

See section 7.0, "Target Recall" for further information.

2.5 Current transformers

The CTs provided with the trip unit are specifically designed to provide both the signal and power required by the trip unit.

The trip unit is powered-up with less than 20% of the rated CT tap current through a single CT. This is below the lowest pick-up setting.

****** IMPORTANT ******

Current inputs from sources other than the CTs designed for the trip unit may damage the internal circuits in the trip unit.

Do not attempt to directly use current sources such as relay test sets, motor overload test sets, setups incorporating variable transformers, etc..

In order to provide the greatest range in pick-up settings, the standard CTs are tapped.

Standard ratings are:

Breaker Frame Size	CT Full Rating	CT Tap Rating
225	225	175
600	600	300
800	800	400
1600	1600	800
2000	2000	1000
3000	3000	1500
4000	4000	2000

Non-standard CT ratings may also be provided by special arrangement with the factory.

2.6 Actuator

The trip unit is designed to function with either the Joslyn Model "MR", manual reset actuator or the Joslyn Model "AR", automatic reset actuator.

The trip unit discharges an internal capacitor to trip the actuator. This trip energy is 25V on a 1000uF capacitor which provides a considerable margin above the maximum trip requirements of either the "MR" or "AR" actuator.

2.7 Battery

A 7-cell, 110mAh, high temperature Nickel-Cadmium battery is incorporated in the trip unit. The battery is under a 5mA trickle charge whenever the trip unit is powered-up.

The battery is **not** involved in the protective functions of the trip unit. **The trip unit will provide protection even with the battery removed.** The battery is also **not** required to maintain any of the memory devices in the trip unit.

The battery provides the following features:

- 1) Target Recall
- 2) Last Trip Data
- 3) Commissioning (without the use of the optional auxiliary power pack)
- 4) Alarm Relay

The battery will slowly self discharge if the breaker is not in service (ie., spare, N/O tie breaker, etc.) or if the normal load on the breaker is less than 20% of the CT tap rating. Under these conditions, it is recommended that the trip unit should have an auxiliary power pack connected. The auxiliary power pack will provide the trickle charge for the battery.

Under normal operating conditions, the battery is expected to operate properly for a minimum of seven years. Since the ambient temperature has the greatest effect on battery life, a high temperature rated battery is used to minimize this effect. Battery failure is indicated when the battery fails to hold a charge.

The condition of the battery can be checked in the following manner:

- 1) If the breaker was not in service or if the normal load on the breaker was less than 20% of the CT tap rating, connect the auxiliary power pack to the trip unit for a 24 hour period to charge the battery.
- 2) With the breaker not in service and the auxiliary power pack disconnected (ie., the trip unit is not powered-up), press the "TARGET RECALL" push button and step through all the settings with the "SETTINGS REVIEW" push button.

If the trip unit goes through the entire settings twice in a row without shutting off (except after the last setting), then the battery is in satisfactory condition.

If the unit shuts off in the middle of the settings then the battery should be replaced.

Note: If the "SETTINGS REVIEW" push button is not pressed for 30 seconds the trip unit will automatically shut off.

After the Instantaneous pick-up setting, the unit will automatically shut off.

The battery can easily be replaced by the user with the battery replacement kit. As an alternate, the trip unit can be returned to the factory authorized repair center for battery replacement.

Units with a serial number above XX35000 have a battery with a connector that plugs onto the printed circuit board.

2.8 Neutral Current Transformer

A neutral CT is only required if the trip unit is equipped with the GF feature and the breaker is installed on a 4-wire system.

The neutral CT is installed on the neutral conductor as shown in Figure 15.1.

Polarity is very important. If either the neutral CT or any of the phase CTs are reversed, a nuisance GF trip will occur.

3.0 External Connections

All external connections are made using three, plug-in terminal blocks as described below (also see Fig. 15.1 and 15.2 for the external wiring/connection diagrams).

3.1 Breaker Wiring Harness (Right Side of Trip Unit)

The Breaker Wiring Harness has a 10-pole, polarized terminal block that plugs into the right side of the trip unit. The connections are as follows from top to bottom:

<u>Terminal #</u>	<u>Wire Color</u>	<u>Use</u>
10	Red	Actuator "+"
9	Black	Actuator "-"
8	Blue	Phase "A" CT
7	White	Phase "A" CT
6	Yellow	Phase "B" CT
5	White	Phase "B" CT
4	Grey or Brown	Phase "C" CT
3	White	Phase "C" CT
2	Green	Neutral CT
1	White	Neutral CT

The actuator wires and each set of the CT wires in the Breaker Wiring Harness are housed inside an individual PVC tube for added physical protection and to simplify the wiring process.

The neutral CT wiring is part of the neutral CT installation kit and is only required with ground fault on a 4-wire system. The ground fault function on a 3-wire system does not require a neutral CT.

The "CT ends" of the breaker wiring harness connect to the #10-32 CT lugs using ring tongue terminals. The **white wire** connects to the **common lug**. The wiring harness may be shortened as required to suite the application.

3.2 Auxiliary Connections (LOWER Left Side of Trip Unit)

The 7-pole, Auxiliary Connection terminal block plugs into the lower LEFT side of the trip unit (see Fig. 15.1 and 15.2). The connections are as follows from top to bottom:

<u>Terminal #</u>	<u>Use</u>
1	Key Switch
2	Key Switch
3	RS485 Port "-"
4	RS485 Port "+"
5	Alarm NC
6	Alarm Common
7	Alarm NO

3.3 Auxiliary Power (UPPER Left Side of Trip Unit)

The 3-pole, Auxiliary Power terminal block plugs into the UPPER left side of the trip unit (see Fig. 15.1 and 15.2). This terminal block is part of the auxiliary power pack. The connections are as follows:

<u>Terminal #</u>	<u>Use</u>
1	24VDC + (or 24VAC)
2	24VDC - (or 24VAC)
3	No Connection

****** IMPORTANT ******

The 3-pole Auxiliary Power plug must be plugged into the UPPER left side of the trip unit ONLY.

The trip unit may be DAMAGED if the Auxiliary Power plug is plugged into a wrong position.

4.0 Security Key

The trip unit contains a security feature that only allows someone familiar with the operation of the trip unit to commission the trip unit or make changes to the settings.

The "Security Key" is simply a short jumper wire that is connected to terminals #1 and #2 of the Auxiliary Connection terminal block (see Fig. 15.1).

To turn the security key "ON":

Place a jumper wire between terminal #1 and #2 of the 7-pole Auxiliary Connection terminal block.

To turn the security key "OFF":

Remove the jumper wire between terminal #1 and #2 of the 7-pole Auxiliary Connection terminal block.

As an option, terminal #1 and #2 of the 7-pole Auxiliary Connection terminal block can be wired to a customer supplied key operated switch.

5.0 Commissioning

When **Opti-Trip II** is first placed in service, it must be commissioned. All the information required for the trip unit to operate properly must be entered before the trip unit will function.

****** IMPORTANT ******

When first placed in service, the trip unit will not function until all the required information is entered.

After the **Opti-Trip II RMS** system is installed on the breaker, the trip unit must be commissioned as follows:

5.1 Power-Up the Trip Unit

The trip unit can be powered-up in the following two ways.

a) Internal Battery

Press "TARGET RECALL" to power-up the trip unit using the internal battery.

When on the battery, the trip unit will shut off if none of the 4 cluster push buttons are pressed for 30 seconds. It is, therefore, best to have all the desired setting readily available before commissioning the unit when using the battery.

If the unit shuts down during the commissioning process, the process must be started again from the beginning.

If the battery charge is low, it is best to use the auxiliary power pack as described below.

b) Power Pack

Plug the auxiliary power pack into a 120V AC outlet.

Plug the cable into the upper end of the left side terminal block. (See the external wiring diagram Fig. 15.1)

Using the power pack, the unit will stay energized as long as necessary to complete the commissioning process.

When the trip unit is energized, the following will alternate on the display:

ENTER DATA

SERIAL # XXXXXXXX

MODEL LSI

or

MODEL LSIG

Where "XXXXXXX" represents the model code and the unique serial number for the trip unit. See section 1.2.

Press the "SETTING REVIEW" push button to continue.

5.2 Security Key

The following will be displayed:

SECURITY KEY OFF

Close the security key. See section 4.0.

5.3 CT Tap Setting

After the security key is closed, the following will be displayed:

CT RATING XXXXA

Where "XXXX" represents the CT tap rating in amps. The CT tap rating can range from 100 amp to 4000 amp in 5 amp steps.

Press and hold the "INCREASE" or "DECREASE" push button as required until the correct CT tap rating is displayed.

**** IMPORTANT ****

The trip unit will not operate properly unless the correct CT tap rating is entered. Verify that all of the phase CTs and the neutral CT (if applicable) are on the same tap.

Press the "ENTER" push button to continue.

5.4 LT Pick-Up Setting

The following will be displayed:

LT PICK-UP XXXXA

Where "XXXX" represents the LT Pick-Up setting in amps.

The LT Pick-Up setting ranges from 40% to 100% of the CT tap rating in steps of 5 amp. **This provides 193 LT Pick-Up settings for a 1600 amp CT tap rating.**

Press and hold the "INCREASE" or "DECREASE" push button as required until the correct LT Pick-Up setting is displayed.

Press the "ENTER" push button to continue.

5.5 LT Delay Setting

The following will be displayed:

LT DELAY XX.XSEC

Where "XX.X" represents the LT Delay band. The LT Delay band is labelled by the number of seconds to trip at 6 times the LT Pick-Up setting.

The LT Delay setting ranges from 2.5 to 30 seconds in steps of 0.5 seconds. **This provides 56 LT Delay bands.**

Press and hold the "INCREASE" or "DECREASE" push button as required until the correct LT Delay setting is displayed.

Press the "ENTER" push button to continue.

5.6 ST Pick-Up Setting

The following will be displayed:

ST PICK-UP OFF

If the ST function is **not desired**, press the "ENTER" push button and go to Step 5.9.

If the ST function is **desired**, press the "INCREASE" push button and the following will be displayed:

ST PICK-UP XXXXA

Where "XXXX" represents the ST Pick-Up in amps.

The ST Pick-Up setting ranges from 150% to 1200% of the LT Pick-Up setting in 100 amp steps. **This provides 169 ST Pick-Up settings for a 1600 amp CT tap rating.**

Press and hold the "INCREASE" or "DECREASE" push button as required until the correct ST Pick-Up setting is displayed.

Press the "ENTER" push button to continue.

5.7 ST Delay Setting

If the ST function was not turned off in section 5.6, then the following will be displayed:

ST DELAY .XXSEC

Where ".XX" represents the ST Delay.

The ST Delay settings are .07, .10, .15, .20 and .35 seconds.

Press and hold the "INCREASE" or "DECREASE" push button as required until the correct ST Delay setting is displayed.

Press the "ENTER" push button to continue.

5.8 ST I²T

If the ST function is not off, then the following will be displayed:

ST I²T OFF

If the I²T ramp is **not desired**, press the "ENTER" push button to move to the next setting.

If the ~~ST~~-I²T ramp **is desired**, press the "INCREASE" push button. The following will be displayed:

ST I²T ON

Pushing the "DECREASE" push button will turn the ST I²T ramp off again.

Press the "ENTER" push button to continue.

5.9 I Pick-Up Setting

The following will be displayed:

I PICK-UP XXXXXA

Where "XXXXX" represents the I Pick-Up in amps.

The I Pick-Up setting ranges from 150% to 1200% of the LT Pick-Up setting in steps of 100 amps. This provides 169 I Pick-Up settings for a 1600 amp CT tap rating.

Press and hold the "INCREASE" or "DECREASE" push button as required until the correct I Pick-Up setting is displayed.

If the I function is **not desired** and the ST function is **not off**, press the "DECREASE" push button until the following is displayed:

I PICK-UP OFF

**** NOTE ****

Having both the ST and I functions off at the same time is not allowed by the trip unit.

Press the "ENTER" push button to continue.

If the trip unit does not have the GF function jump to step 5.13.

5.10 GF Pick-Up Setting

If the trip unit has the ground fault function, the following will be displayed:

GF PICK-UP OFF

If the GF function is **not desired**, press the "ENTER" push button and go to Step 5.13.

If the GF function is **desired**, press the "INCREASE" push button and the following will be displayed:

GF PICK-UP XXXXA

Where "XXXX" represents the GF Pick-Up setting in amps.

The GF Pick-Up setting ranges from 20% to 60% of the CT tap rating in steps of 10 amps. **This provides 65 GF Pick-Up settings for a 1600 amp CT tap rating.**

Press and hold the "INCREASE" or "DECREASE" push button as required until the correct GF Pick-Up setting is displayed.

Press the "ENTER" push button to continue.

5.11 GF Delay Setting

If the GF function is not off, then the following will be displayed:

GF DELAY .XXSEC

Where ".XX" represents the GF Delay.

The GF Delay settings are .10, .15, .20, .30 and .40 seconds.

Press and hold the "INCREASE" or "DECREASE" push button as required until the correct GF Delay setting is displayed.

Press the "ENTER" push button to continue.

5.12 GF I²T

If the GF function is not off, then the following will be displayed:

GF I²T OFF

If the I²T ramp is **not desired**, press the "ENTER" push button to move to the next step.

If the GF I²T ramp **is desired**, press the "INCREASE" push button. The following will be displayed:

GF I²T ON

Pushing the "DECREASE" push button will turn the GF I²T ramp off again.

Press the "ENTER" push button to continue.

5.13 Exit Procedure

The following will be displayed:

PUSH "ENTER" IF

SETTINGS OK

PUSH "REVIEW" TO

REVIEW SETTINGS

If it is desired to review the setting, push the "REVIEW" push button. Make any changes necessary using the "INCREASE" or "DECREASE" push buttons. As before, use the "ENTER" push button to move to each new setting.

If the settings are as desired, push the "ENTER" push button and the settings will be saved in the non-volatile EEPROM memory.

The following will be displayed:

REMOVE KEY TO

COMMISSION UNIT

Remove the "key". See section 4.0.

If the commissioning process was performed using the internal battery, the following will be displayed:

BATTERY POWER

After about 30 seconds the unit will turn itself off.

If the commissioning process was performed using the power pack, the following will be displayed:

LO CURRENT

Unplug the power pack from both the 120V outlet and from the trip unit.

The commissioning process is complete.

6.0 Changing Settings

****** IMPORTANT ******

While it is possible to make changes to the settings with the breaker in service, it is strongly recommended that THE BREAKER SHOULD BE REMOVED FROM SERVICE while making these changes since the trip unit will not be functional during this process.

After the trip unit is commissioned, settings can easily be changed in the following manner.

Close the security key. See section 4.0.

Power up the trip unit by pressing "TARGET RECALL" or by using the auxiliary power pack as described in Section 5.0, Commissioning.

Press the "SETTINGS REVIEW" push button.

Make any changes necessary using the "INCREASE" or "DECREASE" push buttons. Use the "ENTER" push button to move to each new setting.

After going through all the settings, the following will be displayed.

PUSH "ENTER" IF

SETTINGS OK

PUSH "REVIEW" TO

REVIEW SETTINGS

If it is desired to review the setting, push the "REVIEW" push button. Make any changes necessary using the "INCREASE" or "DECREASE" push buttons. As before, use the "ENTER" push button to move to each new setting.

If the settings are as desired, push the "ENTER" push button and the settings will be saved in the non-volatile EEPROM memory.

If power is lost by the trip unit during this process, the old settings will be retained.

The following will be displayed:

REMOVE KEY TO

COMMISSION UNIT

Remove the "key". See section 4.0.

The Settings have been changed.

7.0 Target Recall

Opti-Trip II RMS has an especially useful "target recall" system.

After a breaker trip, the trip unit will display the type of trip such as LT, ST, I or GF (if applicable) and then the phase currents and ground current (if applicable) at the time of trip followed by the present settings. This information is saved in the non-volatile EEPROM memory and is available immediately after a trip or even many years thereafter.

**** NOTE ****
Only the data from the last trip is saved. The second time the breaker trips, the new trip data is written over the first trip data.

The target recall feature can be used with the trip unit energized or de-energized as follows:

- a) With the trip unit de-energized.

When the breaker is open or there is insufficient current through the breaker to power-up the trip unit, press the "TARGET RECALL" push button.

The following will be displayed if there was no last trip.

NO LAST TRIP

Opti-Trip II RMS, Instruction Manual

If there was a last trip, the following will be displayed.

LAST TRIP LT

or

LAST TRIP ST

or

LAST TRIP I

or

LAST TRIP GF

PHASE A XXXXX A

PHASE B XXXXX A

PHASE C XXXXX A

GROUND XXXX A

Where "XXXXX" is the respective instantaneous RMS value of the phase currents at the time of trip and "XXXX" is the value of ground current at the time of trip (if applicable).

Press the "SETTINGS REVIEW" push button and the present settings will be displayed in the following sequence by pressing the "SETTINGS REVIEW" push button.

CT RATING XXXXA

LT PICK-UP XXXXA

LT DELAY XX.XSEC

ST PICK-UP OFF

or

ST PICK-UP XXXXA

&

ST DELAY .XXSEC

&

ST I²T OFF/ON

I PICK-UP XXXXXA/OFF

GF PICK-UP OFF

or

GF PICK-UP XXXXA

&

GF DELAY .XXSEC

&

GF I²T OFF/ON

**** NOTE ****

Pushing the "ENTER", "INCREASE" or "DECREASE" push buttons during "target recall" has no effect because the "key switch" is open.

When pushing "SETTING REVIEW" after the last setting, the trip unit will turn itself off. If the "SETTINGS REVIEW" push button is not pressed for about 60 seconds, the trip unit will turn itself off.

b) With the trip unit energized.

When the breaker is in service and there is sufficient current to power-up the trip unit (no overload conditions in progress), push the "SETTINGS REVIEW" push button. The trip unit will display the last trip data and the present settings as outlined above.

8.0 Normal Operation

Breaker Current Less than 20% of CT Tap Rating:

If the breaker current is less than 20% of the CT tap rating, the display will be blank.

Breaker Current Greater than 20% of CT Tap Rating:

If the breaker current is greater than 20% of the CT tap rating but less than the LT pick-up value or GF pick-up value (if applicable), the following will be seen on the display.

Without ammeter option:

The display will show "NO OVERLOAD"

With ammeter option:

The display will alternately show the phase currents. Any phase current less than 10% of the CT tap rating will not be displayed.

9.0 Alarm Relay

The trip unit is equipped with an alarm relay as a standard feature.

The alarm relay is a latching relay with a form "C" contact.

The alarm relay is latched close on a trip.

The relay is latched open the next time the trip unit is energized. That is, when the "TARGET RECALL" push button is pressed or the breaker is closed again and is carrying current greater than 20% CT tap rating.

See Section 12.0 for the alarm relay contact ratings.

10.0 Testing

A "primary injection" test is recommended as the initial test of the Opti-Trip II RMS retrofit.

10.1 Step 1: Commission the Trip Unit

Before proceeding with the normal primary injection tests, the trip unit must be commissioned to make it functional. See section 5.0 for the commissioning procedure. It is best to use the final pick-up and time delay settings if they are known. If not, use typical settings for the primary injection test.

If the auxiliary power pack was used for commissioning, remember to unplug it for the primary injection test.

10.2 Step 2: Defeat GF (if so equipped)

If the trip unit is equipped with the ground fault function, it will be necessary to defeat ground fault trip to test the remainder of the functions. There are two ways to defeat ground fault trip as outlined below:

- 1) Turn GF to off as described in section 6.0, "Changing Settings". Remember to turn GF back on again after the test.
- 2) Defeat GF trip one time only by:
 - a) The trip unit should **not** be powered-up.
 - b) Close the security key. See section 4.0.
 - c) Push and hold both the "ENTER" and "SETTINGS REVIEW" push buttons.
 - d) Push the "TARGET RECALL" push button. The following will be displayed:

GF DEFEATED

REMOVE <KEY> TO

CONTINUE

- e) Remove the security key. The following will be displayed:

GF DEFEATED

- f) The unit will remain on battery power for 30 seconds after the "TARGET RECALL" push button was pressed. **The test must be started during this time.**
- g) The GF function will be on the next time the trip unit is energized.

10.3 Step 3: Check Power-Up and Verify Proper CT Setting

Before preceding with the normal primary injection test, check the power-up and CT ratio for each phase as follows:

Power-Up:

Temporarily defeat the ground fault function (if so equipped) and inject a current equivalent to 20% of the CT rating. The trip unit should be functioning at this value of current.

CT Ratio:

If equipped with the "ammeter" option, inject a current equivalent to the CT rating and verify that the current displayed on the LCD corresponds with the injected current.

If not equipped with the "ammeter" option, inject a current equivalent to 90% of the LT pick-up setting. The trip unit should display "NO OVERLOAD". Next increase the current to 110% of the LT pick-up setting. After a short period of time, the trip unit should display "OVERLOAD".

CT Connections:

Since the trip unit will display the currents by phase, it is important to verify that each of the wires in the Breaker Wiring harness was connected to the proper CT.

This can be easily verified if the trip unit is equipped with the ammeter option.

If not equipped with the ammeter option, verify the proper CT connections using the target recall feature during the normal primary injection tests.

10.4 Step 4: Primary Injection Tests

Proceed with the normal primary injection test to verify the pick-up and time delay of the various trip functions. The pick-up and time values should be within the tolerance band of the Opti-Trip II RMS time-current curves.

10.5 Step 5: Erase Last Trip Data

After completing the primary injection test, it is important to erase the last trip data from the memory of the trip unit.

**** IMPORTANT ****
Erase the last trip data from the memory of the trip unit after completing the primary injection tests.

It may also be necessary to erase the settings entered during the commissioning setup required for the test.

To erase the memory in the trip unit after completing the primary injection tests, perform the following:

- 1) The trip unit should not be powered-up.
- 2) Close the security key. See section 4.0.
- 3) Push and hold both the "INCREASE" and "DECREASE" push buttons.
- 4) Push the "TARGET RECALL" push button. The following will be displayed:

ERASE COM FLAG?

- 5) If the settings made during the commissioning procedure are to be erased, press the "INCREASE" push button. If the settings are not to be erased, push the "DECREASE" push button.
- 6) The following will be displayed:

ERASE LAST TRIP?

- 7) If the last trip data is to be erased, press the "INCREASE" push button. If the data is not to be erased, push the "DECREASE" push button.

Opti-Trip II RMS, Instruction Manual

- 8) The following will be displayed:

REMOVE <KEY> TO

CONTINUE

- 9) Remove the security key.

****** IMPORTANT ******

If the last trip data is not erased after the primary injection test, the operating personnel may later assume that the breaker interrupted a fault at some time in the past when they use the "TARGET RECALL" feature.

11.0 Communications

Please consult the instruction manual for the JOSCOMMTM communication system.

12.0 Ratings

Ambient Temperature:
-4°F (-20°C) to 150°F (65°C)

Humidity:
95% non-condensing

Conformal Coating:
Silicone, fungus resistant

Current Transformers:
Specially designed with 0.5 amp rated secondary

Enclosure:
Extruded aluminum housing
6.6" X 4.15" X 1.8" nominal overall dimensions

Alarm Contacts:
5A, 1/6HP @ 125,250V AC
1A, 30V DC
0.24A, 125V DC

13.0 Warranty

A conditional 2-year warranty is offered for the Opti-Trip II trip unit.

Full details of the warranty are provided in Joslyn Hi-Voltage Corporation warranty # G.705-008.

14.0 Time-Current Curve

The Time-Current curves are shown in Figure 15.3.

The curves are shown on a 4 X 5 log-log graph with seconds in the vertical direction and normalized current in the horizontal direction.

The phase currents are shown as multiples of the LT pick-up setting. The ground currents are shown as a percentage of the CT tap rating.

Tolerance for the bands are $\pm 10\%$ in the current direction and $\pm 23\%$ in the time direction.

The curves for the following time bands:

LT
ST I²T
GF I²T

are based on the following equation:

$$I^2T = \text{Constant}$$

Where: I is current in amps
T is time to trip in seconds (center of the band)

14.1 LT Trip Time

For phase overload currents, the above equation can be restated as follows:

$$T = TBC_{LT} / X^2$$

Where: T is time to trip in seconds (center of the band)
 X is current in multiples of the LT pick-up setting
 TBC_{LT} is the LT Time Band Constant = 36 X LT time band setting

**** NOTE ****
 The LT Time Band Constant (TBC_{LT}) =
 36 X The LT Time Band Setting in seconds.

EXAMPLE #1:

CT Rating	1600A
LT pick-up	1200A
LT time band	20S
Test Current	3600A

$$TBC_{LT} = 36 \times \text{LT Time Band Setting} = 36 \times 20 = 720$$

$$\text{and } X = 3600A / 1200A = 3$$

therefore:

$$\text{trip time} = T = TBC_{LT} / X^2 \text{ or } 720 / 3^2 = 720 / 9 = 80 \text{ seconds}$$

**** NOTE ****

To determine the LT trip time by calculation:

- 1) Calculate the LT Time Band Constant (TBC_{LT})
- 2) Calculate "X" where
 $X = (\text{test current}) / (\text{LT Pick-Up Setting})$
- 3) Solve the equation:
 $\text{trip time(sec)} = TBC_{LT} / X^2$

14.2 ST Trip Time

With I^2T off or for currents greater than 10 X LT Pick-Up Setting, the ST trip time is a constant equal to the ST Time Band setting.

With I^2T on and for currents less than 10 X LT Pick-Up Setting, the ST trip time is determined by the following equation:

$$T = TBC_{ST} / X^2$$

Where: T is time to trip in seconds (center of the band)
 X is current in multiples of the LT pick-up
 TBC_{ST} is the ST Time Band Constant

**** NOTE ****
The ST Time Band Constant (TBC_{LT}) =
35 for the .35S Time Band
20 for the .20S Time Band
15 for the .15S Time Band
10 for the .10S Time Band
7 for the .07S Time Band

EXAMPLE #2:

CT Rating	1600A
LT pick-up	1200A
ST pick-up	6000A
ST time band	.20S I^2T ON
Test Current	7200A

$$TBC_{ST} = 20$$
$$X = 7200A/1200A = 6$$

therefore:
trip time = $T = TBC_{ST} / X^2$ or $20/6^2 = 20/36 = .556$
seconds

**** NOTE ****
To determine the ST I^2T trip time by calculation:

- 1) Determine the ST Time Band Constant (TBC_{ST})
- 2) Calculate "X" where
 $X = (\text{test current}) / (\text{LT Pick-Up Setting})$
- 3) Solve the equation:
trip time(sec) = TBC_{ST} / X^2

14.3 GF Trip Time

With I²T off or for currents greater than the CT tap rating, the GF trip time is a constant equal to the GF Time Band setting.

With I²T on and for currents less than the CT tap rating, the GF trip time is determined by the following equation:

$$T = TBC_{GF} / X_{GF}^2$$

Where: T is time to trip in seconds (center of the band)
 X_{GF} is current/ CT tap rating
 TBC_{GF} is the GF Time Band Constant

**** NOTE ****
 The GF Time Band Constant (TBC_{GF}) =
 .50 for the .50S Time Band
 .40 for the .40S Time Band
 .30 for the .30S Time Band
 .20 for the .20S Time Band
 .10 for the .10S Time Band

EXAMPLE #3:

CT Rating 1600A
 LT pick-up 1200A
 GF pick-up 480A
 GF time band .20S I²T ON
 Current 640A

$TBC_{GF} = .20$
 $X_{GF} = 640A/1600A = .40$

therefore:
 trip time = $T = TBC_{GF} / X^2$ or $.20/ (.40)^2 = .20/.16 = 1.25$ seconds

**** NOTE ****
 To determine the GF I²T trip time by calculation:
 1) Determine the GF Time Band Constant (TBC_{GF})
 2) Calculate " X_{GF} " where
 $X_{GF} = (\text{test current}) / (\text{CT Tap Rating})$
 3) Solve the equation:
 trip time(sec) = TBC_{GF} / X_{GF}^2

missing

p9

38

Opti-Trip II RMS, Instruction Manual

15.1 External Wiring

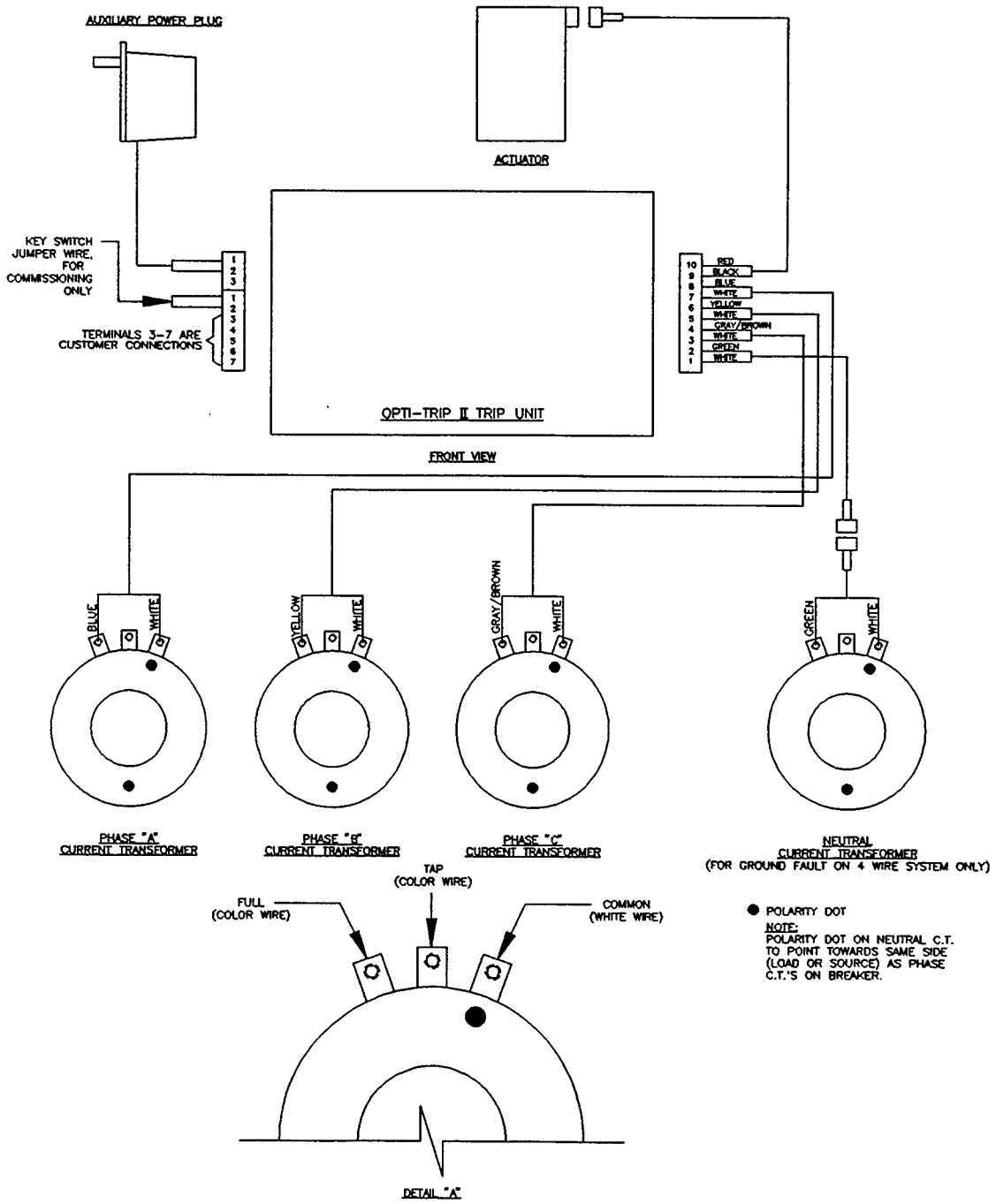

Figure 15.1

missing

pg.

40

15.2 External Connections

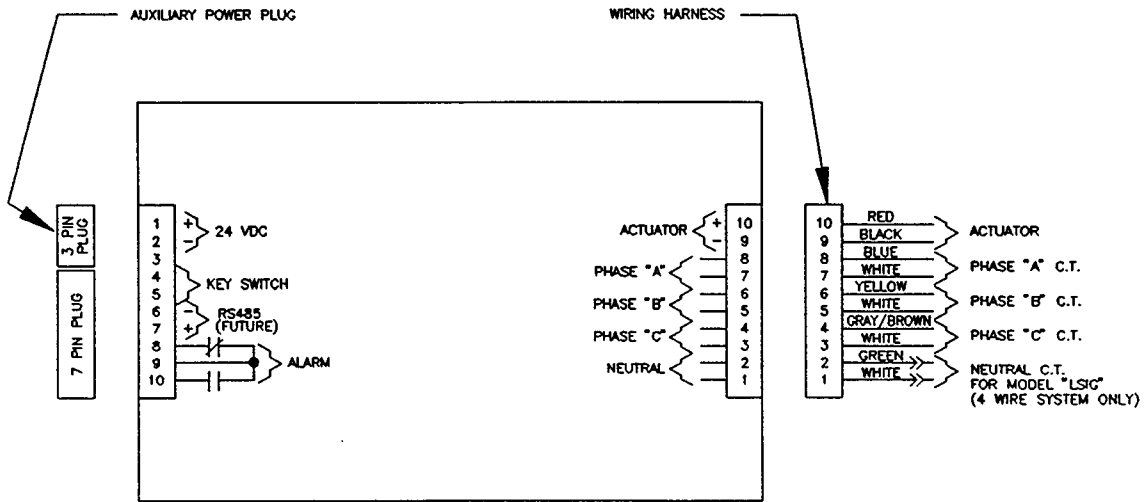

FRONT VIEW OF OPTI-TRIP II

Figure 15.2

Opti-Trip II RMS

List of available retrofit kits

<u>Model #</u>	<u>Breaker Type</u>	<u>Shunts</u>	<u>Operation</u>	<u>Application Notes</u>
General Electric				
1908	AE-1-25 / AE-1-B	-	M	
1915	AE-1-25 / AE-1-B	*	M	
1904	AK-1-25	*	M,E	
1900	AK-2/2A-25	*	M	
1906	AK-3A-25	-	M,E	
1901	AK-1/2/2A-50	*	M,E	
1913	AK-3A-50	-	M,E	
1902	AK-1/2/2A-75	-	E	
1920	AK-3A-75	-		
1921	AK-1/2/2A-100	-		
1922	AK-3A-100	-		
1916	AKR-4A-30	-	M,E	Uses existing actuator
1918	AKR-6D-50	-	M,E	Uses existing actuator
1919	AKR-75	-		Uses existing actuator
1914	AL-2-50 (600A)	*	M	
1907	AL-2-50 (1200)	-	M	
1923	AL-2-50 (1600)	-	M	
1909	AK-1-15	*	M	
1924	AK-2/2A-15	*	M,E	
	AK-4A-100	-		
1925	AKT-1/2/2A-50	*	M,E	
Westinghouse				
2905	DA-50	-	M	No AR Design yet
2906	DA-75	-	E	AR not advisable
2904	DB-15	*	M,E	
2901	DB-25	*	M,E	
2910	DBL-25	*	M,E	
2900	DB-50	*	M,E	
2902	DB-75	-	E	
2911	DB-100	-	E	
2912	DK-15	*	M	
2903	DK-25	*	M	
2908	DS-206	-		Uses existing actuator
2907	DS-416	-		Uses existing actuator
2909	DA-100	-		AR not advisable
Allis-Chalmers				
3900	G-25		M	
3908	G-50/G-50A	-	M	
3907	LA-25	*	M,E	
3901	LA-25A	*	M,E	
3902	LA-50/LA-50A	-	M	
3903	LA-75A	-	E	No MR design yet
3906	LA-600	-	M	No AR required
3909	LA-800	-		No AR required
3904	LA-1600	-	M	No AR required
3905	LA-3000	-	E	No AR required
				Horizontal mount actuator
3910	LA-4000	-		No AR required

3911	LA-3200	-	E	No AR required
Federal Pacific				
4904	FP-25 (600A)	*	M,E	
4906	FP-25 (800A)	*	M,E	
4901	FP-50 (Rear CT's)	*	M,E	Rear mounted CT's
4905	FPS-50	-	M	
4903	FP-75	-	M,E	
4907	DMB-15	*	M	
4900	DMB-25	*	M	
4902	DMB-50	*	M,E	
4909	FPE-100-H2	-		
4910	FP-50 (Front CT's)	*	M,E	Front mounted CT's
4911	FPE -50H-3	-	M	
4912	FPE -75H-3	-	M	
4913	FPE -100H-3	-	M	
Sylvania				
5900	SSPB-600	-	M,E	
5901	SSPB-800	-	M,E	
5902	SSPB-1600	-	M,E	
5903	SSPB-3000	-	M,E	
ITE				
6907	K-225	*	M,E	
6904	K-600	*	M,E	
6900	K-1600 (Red)	*	M,E	
6910	K-1600 (Black)	*	M,E	
6902	K-3000 (Red)	-	E	
6915	K-4000 (Red)	-	E	
6916	K-600-S	-		Uses existing actuator
6913	K-800-S	-		Uses existing actuator
6918	K-1600-S	-		Uses existing actuator
6919	K-1600-S	-		Includes new actuator
6912	K-2000-S	-		
6914	K-3000-S	-		Uses existing actuator
6911	KA			
6901	KB (600A/Slate Back)	*	M	
6909	KB (600A/Steel Back)	*	M	
6903	KC (600A)	*		
6908	KC (1600A/Steel Back)	-		
6905	KC (1600A/Steel Back)	*	M	
6906	KDA-3000 (Black)	-	E	
	K-2000			
6917	LG-3000	-		

The base price of an Opti-Trip II RMS kit includes the Model LSI trip unit, Model MR (manual reset actuator), wiring harness, mounting hardware, and CT's (not including a neutral CT). Certain kits also contain copper detailing as indicated by an asterisk (*).

missing
page
3 of 3