

LV
VOL #
22A

22A

GENERAL ELECTRIC

**GEK 64460A MAINTENACE MANUAL TYPES AKR-75/100
AND AKS-50**



Low Voltage Power Circuit Breakers

Types AKR-75/100 and AKS-50

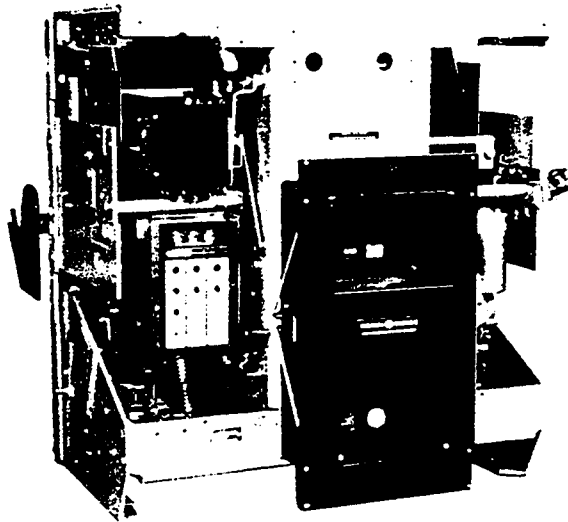

AKR-6D-75

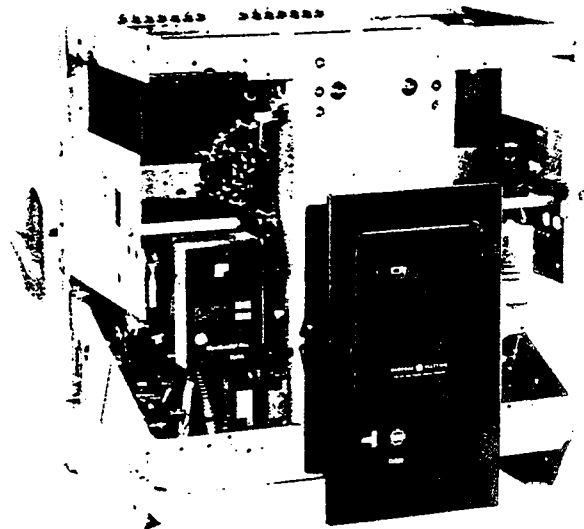

AKR-9D-100

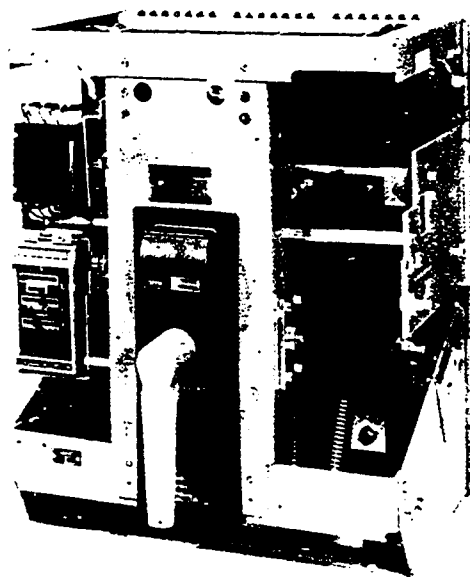

AKS-5A-50

Low-Voltage Power Circuit Breakers

Table of Contents

Description	Page
SECTION 1—Introduction	4
1.1 Inspection and Maintenance	4
1.2 Renewal Parts	4
SECTION 2—General Description	6
2.1 Frame Size	6
2.2 Operation	6
2.3 Mounting	7
2.4 Trip Device	7
2.5 Short Circuit Ratings	7
SECTION 3—Storage, Safety and Maintenance	9
3.1 Storage	9
3.2 Safety	9
3.3 Maintenance	9
SECTION 4—Breaker Operation	10
Manual Closing	10
Electrical Closing	10
4.2.1 Alternate Control Circuit	11
4.3 Connections	12
4.3.1 Stationary Breaker	12
4.3.2 Drawout Breaker	12
4.4 Tripping	13
4.5 Charging and Closing Using the Maintenance Handle	13
SECTION 5—Contact Maintenance	14
5.1 Slow Closing the Breaker	14
5.1.1 Electrical Breaker	14
5.1.2 Manual Breaker	14
5.2 Arc Quencher Removal and Inspection	15
5.2.1 Removal and Replacement	15
5.3 Separation of Front and Back Frames	16
5.4 Back Frame Assembly	18
5.5 Measuring Contact Force	19
5.5.1 Stationary Arcing Contacts	19
5.5.2 Stationary Main and Intermediate Contacts	19
5.6 Measuring Contact Wipe	19
5.7 Adjusting Contact Wipe	19
5.8 Measuring Contact Open Gap	21
5.9 Checking Contact Sequence	22
5.10 Replacement of Contacts	22
5.10.1 Stationary Arcing Contacts	22
5.10.2 Movable Arcing Contacts	22
5.10.3 Movable Main and Intermediate Contacts	23
5.10.4 Stationary Intermediate and Main Contacts	24
5.11 Assembly and Adjustment of Crossbar	25

Description	Page
SECTION 6—Breaker Maintenance	26
6.1 Safety Precautions	26
6.2 Lubrication	26
6.3 Breaker Mechanism Adjustments	26
6.3.1 Trip Latch	26
6.3.2 Latch Buffer	26
6.3.3 Reset Latch Bearing and Prop	26
6.4 Electrical Mechanism	28
6.4.1 Control Components	28
6.4.2 Charging Motor	29
6.4.3 Motor Operator Unit	30
6.4.4 Spring Discharge Interlock	32
6.5 Manual Mechanism	32
6.5.1 Mechanism Part Replacement	33
6.5.2 Ratchet Pawl Replacement	35
6.5.3 Adjustments	35
6.6 Drawout Mechanism	36
6.7 Drawout Mechanism Lock	36
SECTION 7—Accessories	37
7.1 Primary Disconnects	37
7.1.1 AKR 75/100	37
7.1.2 AKS/AKST 50	38
7.2 Secondary Disconnects	39
7.2.1 Replacement	39
7.3 Auxiliary Switch	40
7.3.1 Replacement	40
7.3.2 Adjustments	40
7.4 Shunt Trip	41
7.4.1 Replacement	41
7.4.2 Adjustment	41
7.5 Undervoltage Device	42
7.5.1 Replacement	42
7.5.2 Adjustment	42
7.6 Static Time-Delay Undervoltage	43
7.7 Electric Lockout Device	44
7.7.1 Adjustment	44
7.8 Bell Alarm Device	45
7.8.1 Adjustment	45
7.9 Open Fuse Lockout Device	46
7.9.1 Coil Replacement	46
7.9.2 Adjustments	46
SECTION 8—Type SST Overcurrent Trip Device	47
8.1 Programmer Unit	47
8.2 Current Sensors	48
8.2.1 Replacement of Current Sensors - AKS 50	50
8.2.2 Replacement of Current Sensors - AKR 75/100	51
8.3 Flux Shift Trip Device	51
8.4 Troubleshooting	54
8.4.1 SST Test Set	54

Table of Contents

Description	Page
8.4.2 Resistance Values	55
8.4.3 False Tripping - Breakers Equipped with Ground Fault	55
8.5 SST Cabling Diagrams	55
SECTION 9—Type ECS Overcurrent Trip Device	58
9.1 ECS Cabling Diagram	59
SECTION 10—MicroVersaTrip™ Overcurrent Trip Device	60
10.1 Programmer Unit	60
10.1.1 Fault Trip Indicators	60
10.1.2 Remote Fault Indication	60
10.2 MicroVersaTrip™ Installation	62
10.2.1 AKS 50 Installation	62
10.2.2 AKR 50/100 Installation	63
10.3 Current Sensors	64
10.3.1 Replacement of Current Sensors - AKS 50	65
10.3.2 Replacement of Current Sensors - AKR 75/100	65
10.4 Flux Shift Trip Device	65
10.5 Troubleshooting	65
10.5.1 Resistance Values	66
10.5.2 False Tripping-Breakers Equipped With Ground Fault	67
10.6 MicroVersaTrip™ Cabling Diagrams	67
SECTION 11—RMS-9/Epic MicroVersaTrip®	71
11.1 Programmer Unit	71
11.1.1 Fault Trip Indicators	71
11.2 RMS-9 & Epic MicroVersaTrip Installation	71
11.3 Current Sensors	72
11.3.1 Replacement of Current Sensors	75
11.4 Flux Shifter Trip Device	75
11.5 Troubleshooting	75
11.5.1 Resistance Values	75
11.5.2 False Tripping—Breakers Equipped With Ground Fault	76
11.6 Cabling Diagrams	76
SECTION 12—MicroVersaTrip™ Plus and MicroVersaTrip PM Trip Units	79
12.1 Trip Unit	79
12.2 Read This First	80
12.3 Product Structure	80
12.4 Trip Unit Removal and Replacement	81
12.5 Phase Current Sensors	82
12.6 Neutral Current Sensors	83
12.7 Rating Plug Removal and Replacement	83
12.8 Trip Unit Functions	83
12.9 Trouble-Shooting Guide	84

Description	Page
SECTION 13—Type EC Overcurrent Trip Device	85
13.1 Direct Acting Tripping Device EC-1B	87
13.1.1 Long Time Delay Tripping	87
13.1.2 Short Time Delay Tripping	87
13.1.3 Instantaneous Tripping - High Set	87
13.1.4 Instantaneous Tripping - Low Set	87
13.2 Replacement	87
13.3 Adjustments	88
13.4 Series Overcurrent Tripping Device EC-2A	89
13.4.1 Long Time-Delay and High Set Instantaneous Tripping	89
13.4.2 Instantaneous Low Set Tripping	89
13.4.3 Instantaneous High Set Tripping	89
13.5 Series Overcurrent Tripping Device EC-1	91
13.5.1 Short Time-Delay Tripping	91
13.5.2 Long Time-Delay Tripping	91
13.5.3 Instantaneous Tripping	92
13.5.4 EC-1 Adjustment	92
13.6 Positive Trip Adjustment	92
13.7 Reverse Current Tripping Device	93
13.7.1 Adjustments	94
13.7.2 Replacements	94
13.8 Switchette Feature	94
13.9 Trip Device Replacement	94
SECTION 14—Electrical Characteristics	95
Table 23 Charging and Closing Operating Currents	95
Table 24 Bell Alarm Contact-Rating	95
Table 25 Auxiliary Switch Contact Sequence	95
Table 26 Auxiliary Switch Contact Ratings	95
Table 27 Charging Times	95
Table 28 Shunt Trip and Undervoltage Device	95
Table 29 Coil Resistance	96
Table 30 Instantaneous Undervoltage Device Settings	97
Table 31 Time-Delay Undervoltage Device Settings	97

THESE INSTRUCTIONS ARE INTENDED FOR USE BY QUALIFIED PERSONNEL FOR INSTRUCTION AND MAINTENANCE PURPOSES. REPRODUCTION IN WHOLE OR IN PART IS NOT PERMITTED WITHOUT THE EXPRESS PERMISSION OF GENERAL ELECTRIC.

SECTION 1—Introduction

Introduction

These instructions provide the maintenance procedures and describe the operation of the 1600 thru 4000 amp AC, 6000 amp DC frame size type AKR, AKS low voltage power circuit breakers listed in Table 1 and Table 2.

The proper use, care and maintenance of these breakers is a prime safety consideration for the protection of personnel, as well as a means of minimizing equipment damage when faults occur. Persons who apply, use, and service these breakers will acquire the knowledge they need by gaining the information contained in these instructions.

1.1—Inspection and Maintenance

Breakers should be cared for under a systematic maintenance program. Taking each breaker out of service periodically for inspection and maintenance is an excellent means of establishing high service reliability. It is good policy to have one or more spare breakers to install in place of breakers requiring maintenance. Keeping a stock of recommended renewal parts will insure that maintenance work can be done quickly.

How frequently an individual breaker should be inspected will depend on the circumstances of its use. It would be well to inspect any breaker at least once a year. If it is frequently operated, or installed in an area of high humidity or a dusty, dirty atmosphere, inspections should be more often. Inspections might be monthly under adverse conditions.

Table 1—AKS 50 Designations

FRAME SIZE (Amperes)			DRAWOUT MOUNTING		STATIONARY MOUNTING	NOTES
250V. Dc	600V. Ac	POLES	AKD	AKD-5		
2000	1600	3	AKS-(*)-50 AKS-(*)-50H	AKS-(*)A-50 AKS-(*)A-50H	AKS-(*)S-50 AKS-(*)S-50H	(1)
—	—	2	AKS-(*)-50V	AKS-(*)A-50V	AKS-(*)S-50V	(2)
—	2000	3	AKST-(*)-50H	AKST-(*)A-50H	AKST-(*)S-50H	(1)
—	1600	3	AKSU-(*)-50	AKSU-(*)A-50	—	(3)

(1) The "H" suffix denotes extended short circuit ratings.

(2) Integrally fused models.

(*) This digit identifies the trip device type as follows:

2 = EC-1 or EC-2A (Dc only).

4 = ECS

5 = SST (50/60 Hertz only)

6 = MicroVersaTrip

N = Non automatic. In addition, all non-automatic 250 Vdc breaker types carry the suffix letter D after their frame number, e.g., AKS-N-50D.

EC-1 & EC-2A trip devices are the electro-mechanical type. ECS, SST, MicroVersaTrip™, RMS-9 and MVT-Plus or MVT-PM are Solid State. For detailed information on these trip devices refer to Sections 8 thru 11.

7 = RMS-9

9 = MVT-PLUS or MVT-PM

A basic maintenance inspection should consist of an overall visual check, plus observation of a few closing and opening operations. If a breaker is seldom operated such that it remains open or closed for a period of six months or more, it is recommended that arrangements be made to open and close it several times in succession.

Dirt, grease or other foreign material on any parts of the breaker should be removed by a thorough and careful cleaning. Insulating surfaces should be checked for conditions that could degrade insulating properties.

During an inspection, the breaker's contacts should be slow-closed manually (with closing springs restrained by the safety pin) to observe contact alignment and to insure that all mechanism parts move freely. A complete contact inspection, including measurement of wipe and force, should also be done.

To properly inspect contacts, the arc quenchers must be removed. At this time thoroughly inspect the inside surfaces of the arc quencher side plates and inner components.

1.2—Renewal Parts

The AKR breakers contain a variety of parts and assemblies. Many of these parts and assemblies are available as replacement parts when the need arises. See publication GEF4552, Renewal parts, for a complete listing of these parts.

Table 2—AKR 75/100 Designations

FRAME SIZE (Amperes)		BREAKER DESIGNATION	MOUNTING TYPE					DEEP ESCUTCHEON	PRIMARY STUD TYPE	BREAKER WIDTH (Inches)	
250V. Dc	600V. Ac 50/60 Hz.		DRAWOUT				Sub- Structure				Stationary
			AKD	AKD-5	AKD-6	AKD-8					
4000	3000	AKR-(*)-75						X	Bar	25	
		AKR-(*)A-75	X						Tube		
		AKR-(*)B-75		X	X				Tube		
	3200	AKR-(*)C-75			X		X		X		Fingers
		AKR-(*)D-75				X			X		Fingers
		AKR-(*)F-75					X		X		Fingers
		AKR-(*)S-75						X			Bar
① 3200	AKR-(*)D-75H				X				Fingers		
	AKR-(*)F-75H					X			Fingers		
6000	4000	AKR-(*)-100	X						Tube	33	
		AKR-(*)A-100		X	X				Tube		
		AKR-(*)B-100					X		X	Fingers	25
		AKR-(*)C-100			X					Fingers	
		AKR-(*)D-100				X			X	Fingers	
		AKR-(*)F-100					X		X	Fingers	
		AKR-(*)S-100						X		Bar	
		AKR-(*)W-100						X		Bar	

SPECIAL DC BREAKERS FOR FIELD SWITCHING

4000	ARK-N-75F	X							Tube	25
	AKR-NB-75F					X		X	Fingers	
	AKR-ND-75F				X			X	Fingers	
	AKR-NF-75F					X		X	Fingers	
	AKR-NS-75F						X		Bar	
6000	AKR-N-100F	X							Tube	33
	AKR-NB-100F					X		X	Fingers	
	AKR-ND-100F				X			X	Fingers	
	AKR-NF-100F					X		X	Fingers	
	AKR-NS-100F						X		Bar	25
	AKR-NW-100F						X		Bar	33

Example: AKR-5B-75 identifies a drawout, substructure-mounted breaker equipped with the SST trip device. The EC trip devices are electro-mechanical, refer to GEI 86157 for detailed information.

Breaker Models

(*) This digit identifies the trip device:

2 = EC-1B. Dc only.

4 = ECS

5 = SST 50/60 Hertz only.

6 = MicroVersaTrip 50/60 Hertz only.

7 = RMS-9

9 = MVT-PLUS or MVT-PM

For detailed information on these trip devices refer to Sections 8 thru 11.

N = Non-automatic.

In addition, all non-automatic 250V.

Dc breaker types carry the suffix letter D after the frame number, e.g., AKR-NB-75D.

‡ AKR-75H not available for DC applications.

SECTION 2—General Description

General Description

Type AKR low-voltage power circuit breakers are used for controlling and protecting power circuits in the low-voltage range (usually up to 600 volts). In serving this function, they are a means of safely switching loads and automatically clearing circuits when abnormal conditions occur. Among these conditions, the more common are short circuits and sustained overloads and undervoltages.

The type AKR breakers are of the "quick-make, quick-break" description, having the feature of storing energy in a closing spring for quick release in closing. In closing, some energy is transferred to an opening spring to be used subsequently for fast tripping.

Knowledge of how the breaker is designed and how it operates will enable the purchaser to make proper use of the breaker and to avoid mistakes in its operation. Specific directions on adjustments and maintenance procedures will be treated later.

The three main functional components of a breaker are its mechanism, an assembly comprising the conductive members, and the interrupter.

The mechanism unit is designed to receive energy, store it, and later (when called upon to do so) deliver it to close the breaker contacts. It must be able to reverse its commitment to close the breaker at any point upon the activation of an automatic trip device (i.e., be "Trip-Free"). Finally, it also must be able to trip open a closed breaker quickly enough to minimize arc erosion and in such a manner as to effect proper arc transfer to the arc runner.

The current-carrying members of the breaker are assembled on the back frame, which provides the mechanical support required and also the insulating structure needed. The conductive members are the studs for external connections, movable and stationary contact sets, pivots for the movable contacts, and provision for mounting the current transformers.

The interrupter components are, in addition to the arcing contacts, the arc runners mounted on the back base and the removable arc quencher assemblies.

In addition to these basic components, a breaker may be equipped with any combination of many accessories and interlocking devices.

Individual breakers may differ in a variety of areas as shown in Tables 1 and 2. A brief description of these areas follow.

An outline drawing is available for each breaker frame size showing critical dimensions. The drawing number appears on the breaker nameplate and can be obtained from GE.

2.1—Frame Size

AKR 75 breakers are available in three frame sizes—3200 amperes A.C. and 4000 amperes D.C. There is also available, for replacement or hole filler application on AKD or AKD5 switchgear a 3000 amperes A.C. frame.

AKR 100 breakers are available in two frame sizes—4000 amperes A.C. and 6000 amperes D.C.

AKS 50 (replacement breaker for the AK50) is available in two frame sizes—1600 amperes A.C. and 2000 amperes A.C. or D.C. depending on trip device.

These values represent the maximum continuous current capability of the respective frames. However, each breaker carries a specific rating which is determined by the current sensor ampere rating or tap setting of the trip device with which it is equipped.

Individual breaker rating data is shown in Table 5.

2.2—Operation

There are Manual and Electrical models. The Manual breaker has an operating handle which is used to manually charge the mechanism closing spring. Figure 1 shows a typical Manual breaker.

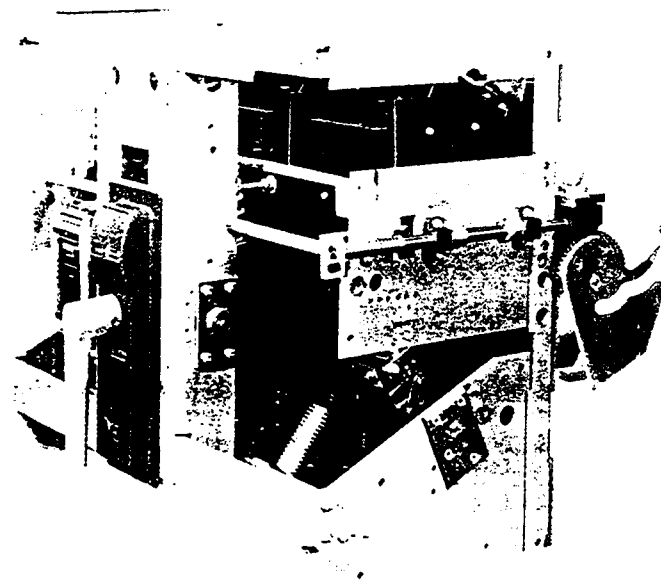

Fig. 1. Manually operated, AKD type

The Electrical breaker contains an electric motor which charges the mechanism closing spring. External control power is required to energize this motor and its control circuit. A nameplate indicates what voltage is required by the motor circuit. Figure 2 shows a typical Electrical breaker.

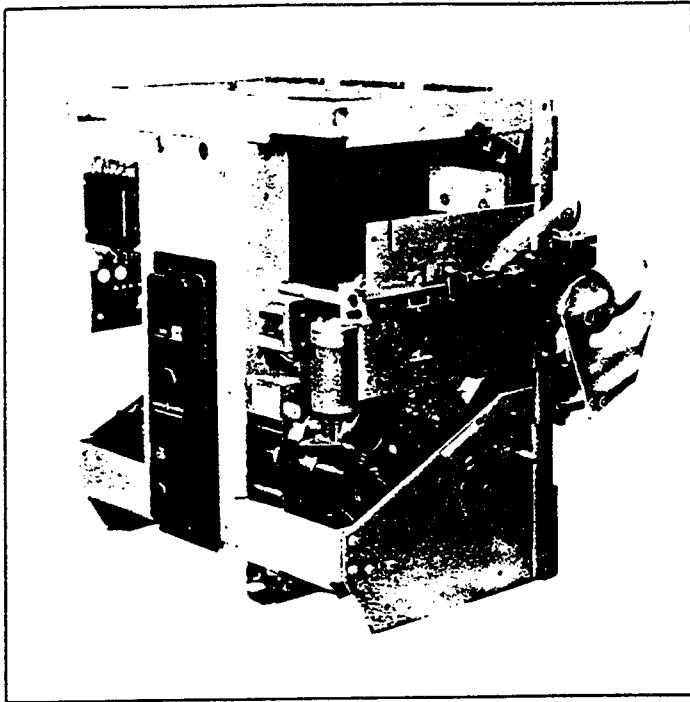

Fig. 2. Electrically operated, AKD type

2.3—Mounting

AKR-75 and -100 breakers are furnished in both drawout and stationary construction. Drawout breakers are equipped with features which make them easy to install in or withdraw from their associated switch-gear equipment. Stationary breakers are designed to be mounted in a switchboard or enclosure. Mounting consists of bolting the breaker frame to a supporting structure within the switchboard or enclosure. If control power connections are needed, a suitable terminal board is supplied.

The mounting type is identified by the second middle digit in the breaker nameplate designation as follows:

AKR-4(t)-75, where
(t) = mounting type code letter per Table 3

Table 3—Mounting Type Codes

Code Letter	Breaker Type	
	Drawout	Stationary
None	AKD	----
A	AKD-5, 6	----
B	Substructure	----
C	AKD-6 Only	----
D	AKD-8	----
F	Substructure	----
S	----	AKR-75/100 (25" wide)
W	----	AKR-100 (33" wide)

2.4—Trip Device

There are six types of solid-state, direct-acting self-powered trip device systems associated with AKR breakers. These systems are for AC applications only. For DC applications an electromechanical system is available.

The trip device system is identified by the first middle digit in the breaker's nameplate designation as follows:

AKR-(t) C-75
(t) = trip device code per Table 4

Table 4—Trip Device Codes

CODE NUMBER	TRIP DEVICE	APPLICATION
2	EC ¹	DC
3	Power Sensor ²	AC
4	EC	AC
5	SST	AC
6	MicroVersaTrip	AC
7	RMS-9	AC
9	MVT-PLUS or MVT-PM	AC

¹EC devices. See Section 11.

²Power Sensor devices are discontinued. See publications GEK-7301 and GEK-7309 for detailed servicing procedures.

2.5—Short Circuit Ratings

Short circuit ratings vary with the applied system voltage. On 240 VAC systems they are also dependent upon whether the overcurrent trip device contains an instantaneous trip element. See Table 5.

Table 5—Breaker Interruption Ratings

Frame Size (Amperes)	Breaker Type	Rated Maximum Voltage (60 Hz AC)	30 Interruption Rating KA RMS Symmetrical		Short Time
			Instantaneous Trip		
			With	Without	
1600 AC	AKS-50	635	42	42	42
		508	50	50	50
		254	65	50	42
	AKS-50H	635	65	65	65
		508			
		254			
AKSU-50	600	200	200	—	
2000 AC	AKST-50H	635	42	42	42
		508	65	65	
		254			
3200 AC	AKR-75	635	65	65	65
		508			
		254			
	AKR-75H	635	85	85	85
		508			
		254			
AKR-75 (fused)	600	200	200	—	
4000 AC	AKR-100	635	85	85	85
		508			
		254			
	AKR-100 (fused)	600	200	200	—
2000 DC	AKS 50 AKS 50V	300V DC	50 ①	②	—
4000 DC	AKR 75	300V DC	50	50	—
6000 DC	AKR 100	300V DC	50	50	—

① With 200-2000 amp trip coils

② Consult factory for application data

SECTION 3—Storage, Safety & Maintenance

3.1—Storage

It is recommended that the breaker be put into service immediately in its permanent location. If this is not possible, the following precautions must be taken to insure the proper storage of the breaker:

1. The breaker should be carefully protected against condensation, preferably by storing it in a warm dry room, since water absorption has an adverse effect on the insulation parts. Circuit breakers for outdoor switchgear should be stored in the equipment only when power is available and the heaters are in operation to prevent condensation.
2. The breaker should be stored in a clean location free from corrosive gases or fumes. Particular care should be taken to protect the equipment from moisture and cement dust, as this combination has a very corrosive effect on many parts.

CAUTION: IF THE BREAKER IS STORED FOR ANY LENGTH OF TIME, IT SHOULD BE INSPECTED PERIODICALLY TO SEE THAT RUSTING HAS NOT STARTED AND TO ASSURE GOOD MECHANICAL CONDITION. SHOULD THE BREAKER BE STORED UNDER UNFAVORABLE ATMOSPHERIC CONDITIONS, IT SHOULD BE CLEANED AND DRIED OUT BEFORE BEING PLACED IN SERVICE.

3.2

Each user must maintain a safety program for the protection of personnel, as well as other equipment, from the potential hazards associated with electrical equipment.

The following requirements are intended to augment the user's safety program, but **NOT** supplant the user's responsibility for devising a complete safety program. The following basic industry practiced safety requirements are applicable to all major electrical equipment such as switchgear or switchboards. General Electric neither condones nor assumes any responsibility for practices which deviate from the following:

1. ALL CONDUCTORS MUST BE ASSUMED TO BE ENERGIZED UNLESS THEIR POTENTIAL HAS BEEN MEASURED AS GROUND AND SUITABLE GROUNDING CONDUCTORS HAVE BEEN APPLIED TO PREVENT ENERGIZING. Many accidents have been caused by back feeds from a wide variety of sources.
2. Although interlocks to reduce some of the risks are provided, the individual's actions while performing service or maintenance are essential to prevent accidents. Each person's knowledge; his mental awareness; and his planned and executed actions often determine if an accident will occur. The most important method of avoiding accidents is for all associated personnel to carefully apply a thorough understanding of the specific equipment from the viewpoints of its purpose, its construction, its operation and the situations which could be hazardous.

All personnel associated with installation, operation and maintenance of electrical equipment, such as power circuit breakers and other power handling equipment, must be thoroughly instructed, with periodic retraining, regarding power equipment in general as well as the particular model of equipment with which they are working. Instruction books, actual devices and appropriate safety and maintenance practices such as OSHA publica-

tions, National Electric Safety Code (ANSI C2), The National Electrical Code, and NFPA 70B Electrical Equipment Maintenance must be closely studied and followed. During actual work, supervision should audit practices to assure conformance.

3. Excellent maintenance is essential for reliability and safety of any electrical equipment. Industry publications of recommended maintenance practices such as ANSI/NFPA 70B, Electrical Equipment Maintenance, should be carefully studied and applied in each user's formation of planned maintenance.

3.3

Both long and short term maintenance of all electrical equipment is essential for reliability and safety. Maintenance programs must be tuned to the specific application, well planned and carried out consistent with both industry experience and manufacturer's recommendations. Local environment must always be considered in such programs, including such variables as ambient temperatures, extreme moisture, number of operations, corrosive atmosphere or major insect problems and any other unusual or abusive condition of the application.

One of the critical service activities, sometimes neglected, involves the calibration of various control devices. These monitor conditions in the primary and secondary circuits, sometimes initiating emergency corrective action such as opening or closing circuit breakers. In view of the vital role of these devices, it is important that a periodic test program be followed. As was outlined above, it is recognized that the interval between periodic checks will vary depending upon environment, the type of device and the user's experience. It is the General Electric recommendation that, until the user has accumulated enough experience to select a test interval better suited to his individual requirements, all significant calibrations be checked at an interval of one to two years.

To accomplish this, some items, such as "EC" direct operating trip systems for low voltage breakers, must be tested with primary current injection. Others can be adequately tested using test sets. Specific calibration instructions on particular devices typically are provided by supplied instruction books.

Instruction books supplied by manufacturers address components that would normally require service or maintenance during the useful life of the equipment. However, they can not include every possible part that could require attention, particularly over a very long service period or under adverse environments. Maintenance personnel must be alert to deterioration of any part of the supplied switchgear, taking actions, as necessary to restore it to serviceable status.

Industry publications of recommended maintenance practices such as ANSI/NFPA 70B, Electrical Equipment Maintenance, should be carefully studied and applied in each user's formation of planned maintenance.

Some users may require additional assistance from General Electric in the planning and performance of maintenance. The General Electric Company can be contracted to either undertake maintenance or to provide technical assistance such as the latest publications.

The performance and safety of this equipment may be compromised by the modification of supplied parts or their replacement by non identical substitutes. All such design changes must be qualified to ANSI/IEEE Standard C37.50.

The user should methodically keep written maintenance records as an aid in future service planning and equipment reliability improvement. Unusual experiences should be promptly communicated to the General Electric Company.

SECTION 4—Breaker Operation

Breaker Operation

The AKS-50, AKR-75 and AKR-100 breakers are closed by the discharging of the energy stored in the closing springs of the breaker. As the closing springs are discharged, the energy is directed into the closing cam of the breaker which causes the moveable breaker contacts to be forced against the stationary contacts, and, at the same time causes the opening springs to be charged so they may open the breaker during a subsequent opening operation.

4.1—Manual Closing

Manually operated breakers are equipped with a handle which extends from the escutcheon of the breaker. Alternately rotating the closing handle counterclockwise then clockwise through approximately 120 degrees of rotation through four complete cycles will cause the breaker to close. During the four counterclockwise movements and the first three clockwise movements of the handle, the springs are progressively charged. After approximately seven degrees travel of the fourth clockwise handle movement, the spring charge mechanism is driven "over center" and the energy stored in the closing springs is directed into the closing cam and causes the breaker to close. A charge-indicator, numbered one to four, visible through the breaker escutcheon, indicates the number of complete handle movements that have been performed.

4.2—Electrical Closing

On electrically operated breakers, the closing springs are charged by a gear motor. With the springs discharged, voltage applied to the control circuit will energize the motor through the "G" switch contacts—see figs. 3A & 3B. The motor, through the gear reduction output crank, compresses the closing springs until they are fully charged. As this fully charged position is reached, mechanically operated switch "G" reverses its shown position, deenergizing the motor. In the fig. 3A diagram switch "F" reverses its position and establishes a circuit for the "X" relay. At the same time, a mechanical prop is positioned to prevent the discharge of the fully charged closing spring.

With the closing spring propped fully-charged, the breaker is ready for closing. This may be accomplished electrically by depressing the closing button on the breaker (if so equipped) or by a remote closing switch. Operation of the closing switch energizes the "X" relay, which in turn energizes the closing solenoid. This removes the prop, releasing the closing springs to close the breaker.

As the closing relay is energized, it energizes anti-pump relay "W". If the closing switch is maintained closed, the anti-pump relay will remain picked-up to prevent a second closing operation on the breaker in the event it is tripped open automatically. The closing impulse must be released and reapplied before a second closing operation can occur.

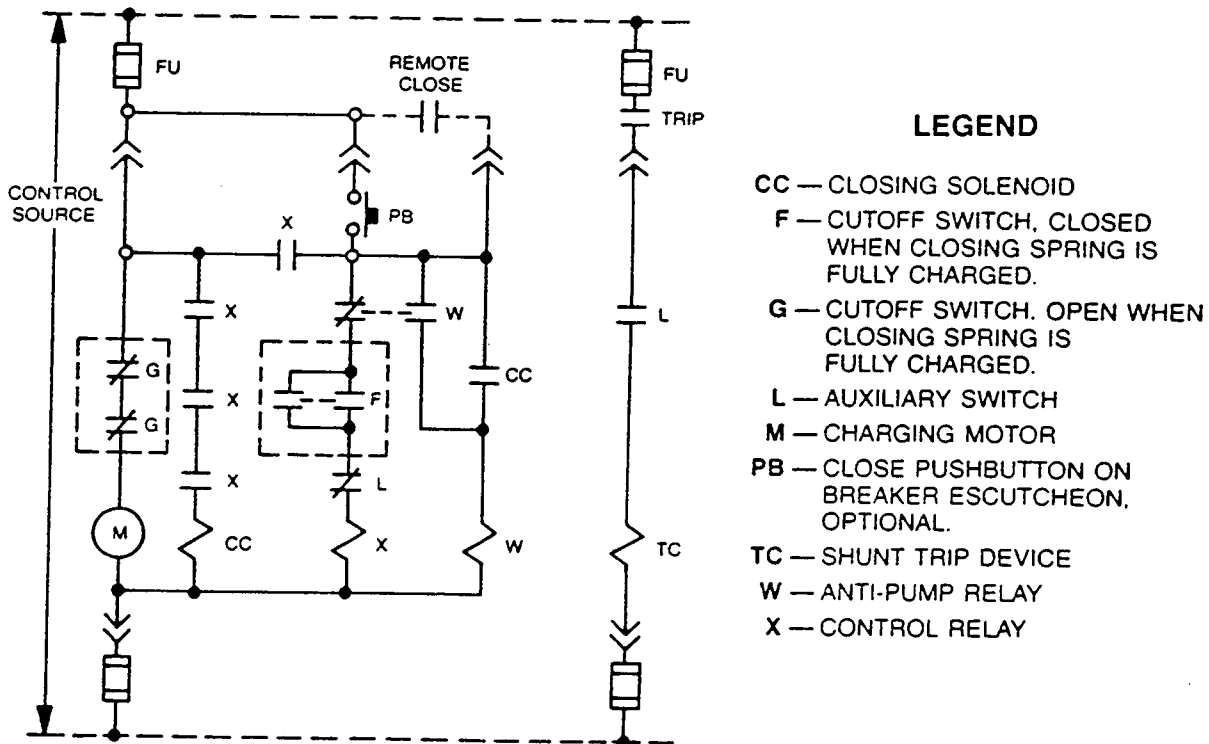

Fig. 3A. Elementary diagram for electrically operated drawout breaker. Contact positions are shown with breaker open and closing springs discharged. TYP #568B736 "R" series.

4.2.1—Alternate Control Circuit

Later production breakers use the electrical control circuit shown in Fig. 3B. This circuit is similar to the circuit shown in Fig. 3A except that the X-relay and 'F' switch are eliminated.

The motor is energized through the 'G' switch and the W-relay contact. The 'G' switch deenergizes the motor when the closing springs are charged and the prop is engaged.

With the closing spring propped fully-charged, the breaker is ready for closing. This may be accomplished electrically by depressing the closing switch on the breaker (if so

equipped) or by a remote closing switch. Operation of closing switch energizes the W-relay, which in turn energizes the closing solenoid. This removes the prop, releasing the closing springs to close the breaker.

If the closing switch is maintained closed, the anti-pump relay will remain picked-up to prevent a second motor charge and closing operation on the breaker in the event it is tripped open automatically. The closing impulse must be released and reapplied after the closing springs are fully-charged before a second closing operation can occur. The charging time is typically 1 to 3 seconds depending on voltage and the maximum time permitted is 5 seconds.

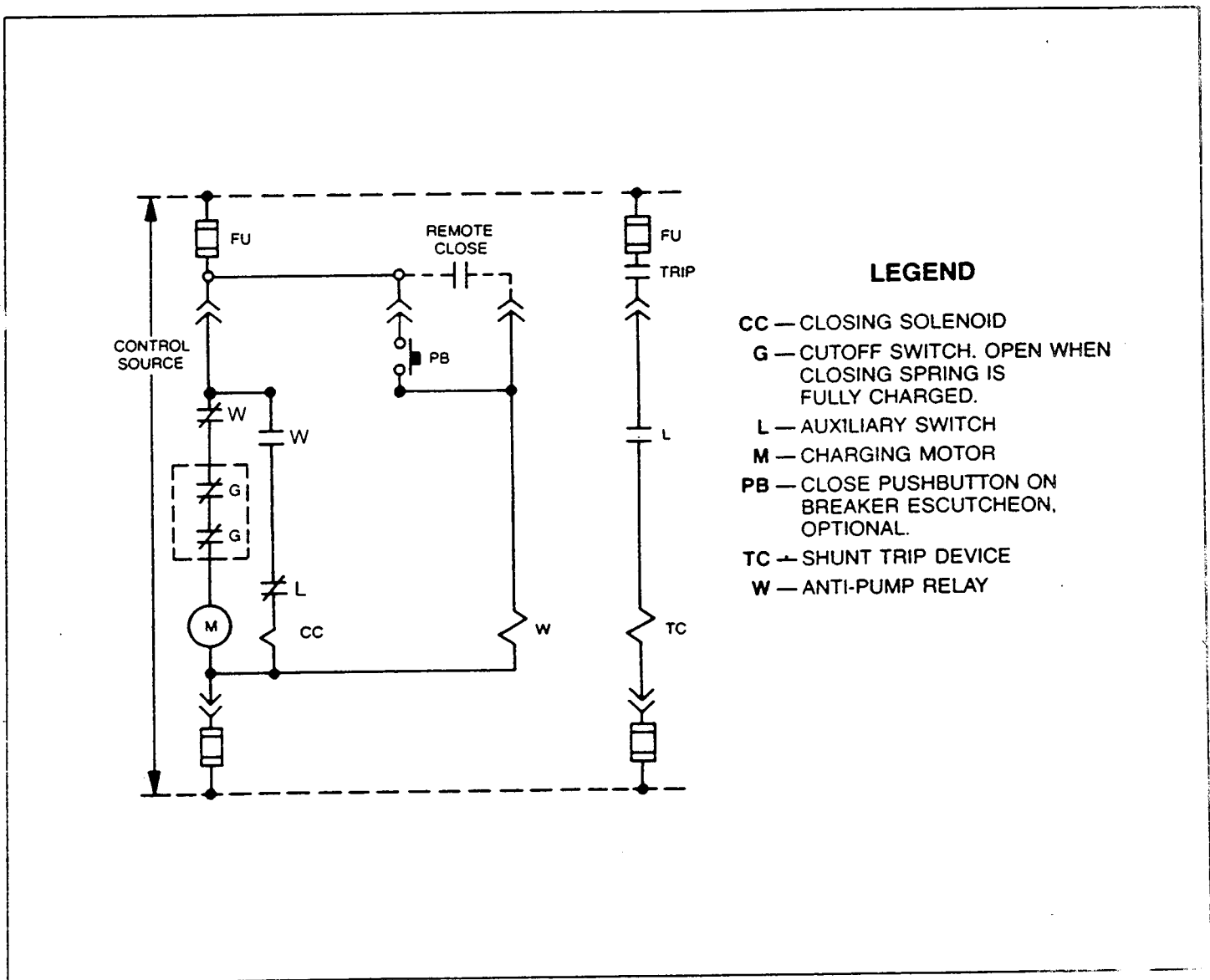

LEGEND

- CC — CLOSING SOLENOID
- G — CUTOFF SWITCH. OPEN WHEN CLOSING SPRING IS FULLY CHARGED.
- L — AUXILIARY SWITCH
- M — CHARGING MOTOR
- PB — CLOSE PUSHBUTTON ON BREAKER ESCUTCHEON, OPTIONAL.
- TC — SHUNT TRIP DEVICE
- W — ANTI-PUMP RELAY

Fig. 3B. Alternate elementary diagram. Contact positions are shown breaker open and closing springs discharged. TYP #568B736 "B" series.

SECTION 4—Breaker Operation

4.3—Connections

In all electrical connections good joint conductivity is a must. When making power connections to stationary breakers, the mating joint surfaces must be clean and have a smooth finish. They should be parallel and firmly bolted or clamped together. In addition, the bus or cable conductors must have ample ampacity to prevent overheating.

The outgoing connections to breaker accessories and control devices must be in accordance with the specific wiring diagram applicable to that breaker.

4.3.1—Stationary Breaker

Control connections to stationary breakers are made to a terminal board mounted on the breaker. Figure 4 shows typical closing and tripping connections. If equipped with an overcurrent trip device which includes a ground fault element for use on 4-wire circuits, an additional terminal board is provided on the breaker for connecting to the equipment-mounted neutral sensor (physically located in the neutral conductor).

4.3.2—Drawout Breaker

On drawout breakers the control circuits terminate in the breaker compartment on the stationary portion of separable secondary disconnects — see fig. 5.

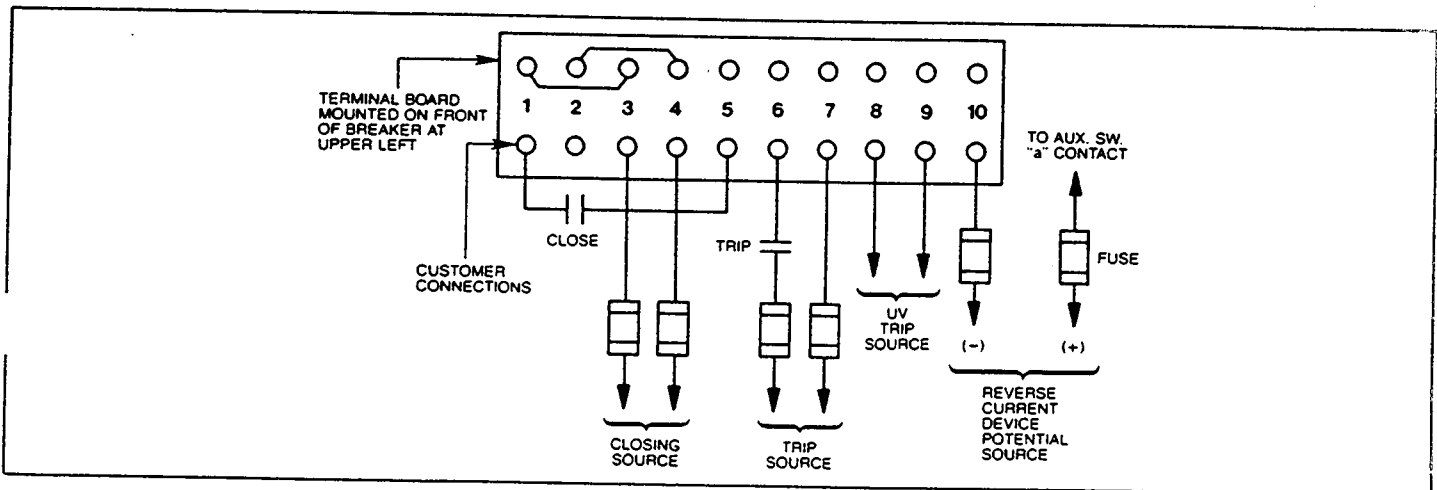

Fig. 4. Control connections to stationary breakers—front view

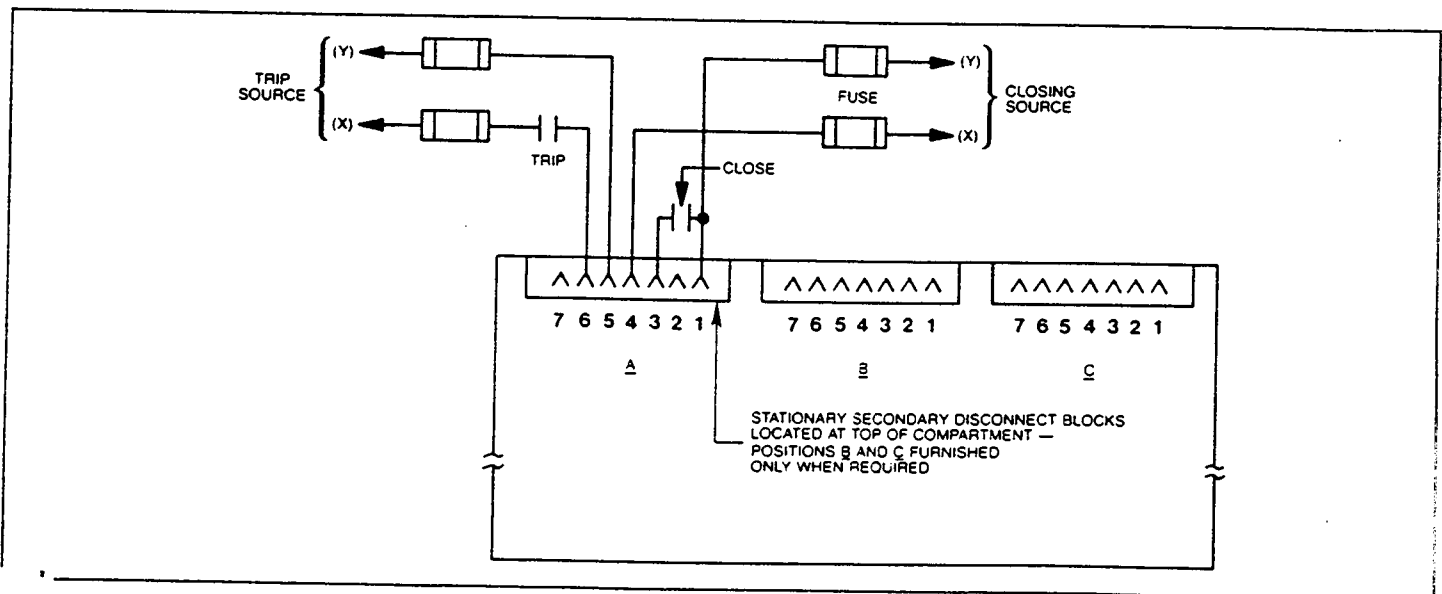

Fig. 5. Control connections to drawout breakers — front view of breaker compartment

4.4—Tripping

In the closed position, the breaker movable contacts are held in by a toggle linkage. The breaker is tripped open by displacing a mechanism latch which allows this toggle linkage to collapse. The trip latch is rigidly fastened to a horizontal trip shaft running from left to right through the breaker. In turn, the trip shaft carries paddles actuated by the manual trip button and the various other trip devices — overcurrent, reverse current, shunt trip, undervoltage, open fuse lockout. Viewing the breaker from the right, rotating the trip shaft counterclockwise trips the breaker; clockwise movement resets the mechanism latch.

In addition to tripping the breaker, some devices hold the breaker trip free, i.e., prevent the contacts from closing even though a closing impulse is applied to the mechanism. Such devices are the undervoltage, bell alarm and lockout, electric lockout, open fuse lockout, and the key operated locks.

These devices and the drawout mechanism interlocks must be in the reset position before the breaker can be closed.

4.5—Charging and Closing Using the Maintenance Handle

In the absence of control power, an electric breaker can be closed manually by using the maintenance handle to charge the closing springs. Referring to Fig. 6:

(a) With the breaker open and springs discharged release holding pawl slide per instruction label (2).

(b) Install maintenance crank (1) (568B386G1) to the motor gear reducer shaft on the front right side of the breaker. Ratchet the maintenance crank up and down until the springs are fully charged as indicated by the distinct click as the prop is set. This prevents any further charging of the closing springs. After the prop is set do not apply undue force to the maintenance handle.

(c) Depress the "Spring Discharge" lever (3) located under the horizontal support on the front frame. The springs should discharge and if the latch is properly reset, the breaker will close. Some style breakers, because of an interlock in the switchgear, can not be manually closed in the fully engaged position.

(d) Open the breaker by pushing the trip button (4).

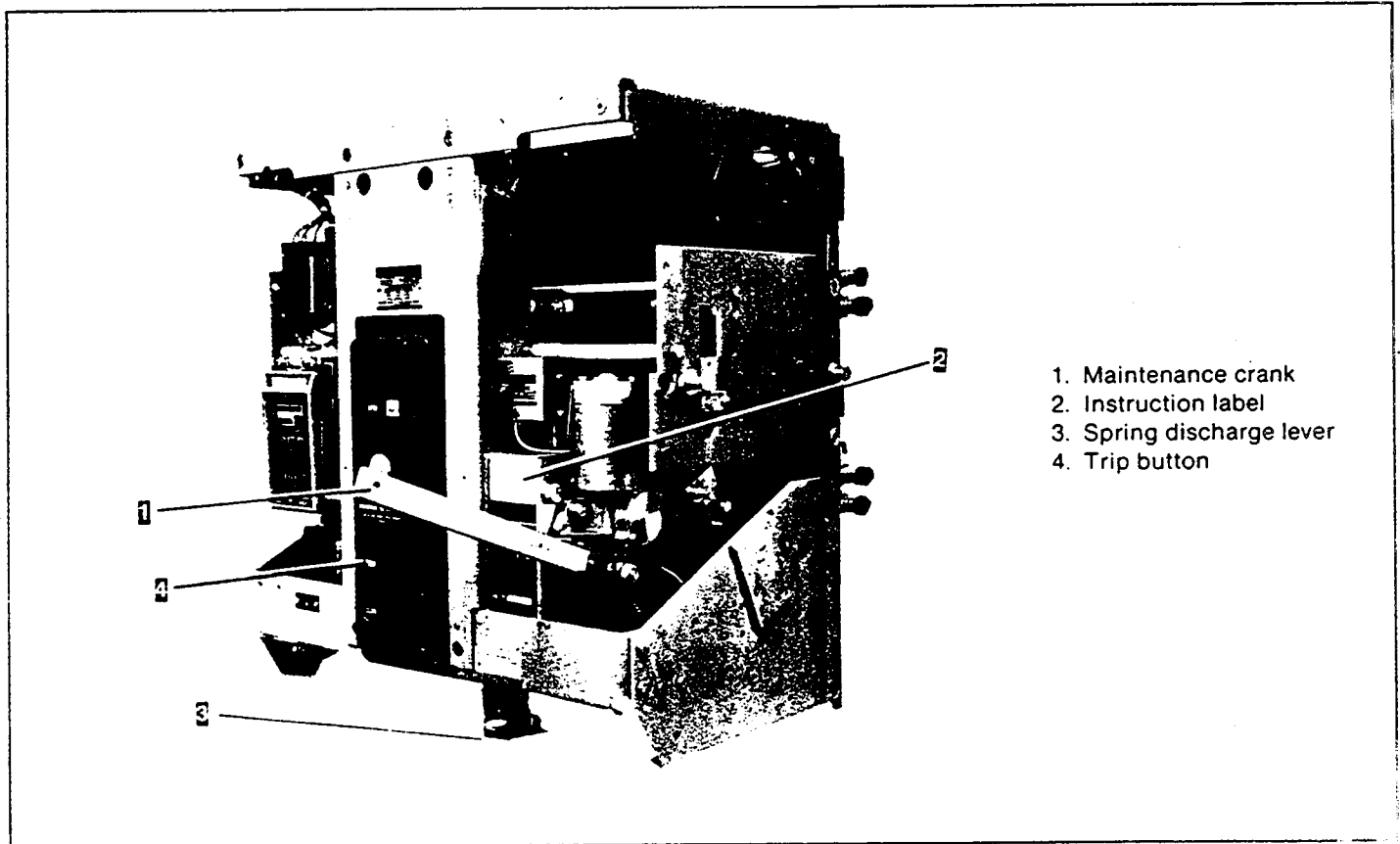

Fig. 6. Maintenance handle charging

SECTION 5—Contact Maintenance

Contact Maintenance

Breakers subjected to frequent interruption of high currents may eventually require replacement of their contacts. The general rule for determining need of replacement is the loss of one-half or more of the mass of the contact tip material. Roughening or light pitting of the contact surface does not indicate loss of ability to carry or interrupt current.

For proper operation of the breaker, the contact structures must be correctly adjusted. Various interrelated adjustment parameters are involved. Specific amount of contact pressure and wipe must exist between moveable and stationary contacts. The arcing, intermediate and main contact assemblies must engage and disengage in a prescribed sequence; and with breaker open, an adequate gap must exist between the movable and stationary arcing contacts.

5.1—Slow Closing the Breaker

To perform contact maintenance work the breaker operating mechanism must be "slow-closed", i.e. manually driven and controlled at will instead of in the high-speed manner produced by spring discharge. Slow closing is achieved by preventing the closing springs from acting on the mechanism. The breaker is arranged for slow closing manually charging the springs and then securing them in this compressed state by inserting a restraining "safety pin" see Fig. 7.

Following the inspection period,

- a. Recharge the closing springs.
- b. Remove the safety pins from the guide rods, return them to their storage clips.

5.1.1—Electrical Breaker

Referring to Fig. 7:

- a. Attach maintenance handle (1) and charge the closing springs until the crank roller contacts prop (4).
- b. Insert safety pins (3) into the holes in the guide rods (2).
- c. Release the prop by depressing closing lever (5). The safety pin now takes the full force of the spring and restrains it. Now free from spring influence, the breaker contacts can be inspected and moved at will to the fully closed position by means of the maintenance handle.

5.1.2—Manual Breaker

- a. Operate the breaker closing handle through $3\frac{1}{2}$ complete movements to charge the closing springs.
- b. Insert the safety pins into the guide rods.
- c. Continue to operate the closing handle (4th downstroke) until the spring crank goes over center, applying full spring force to the safety pin. Closing motion now can be continued and is completely controlled by the breaker closing handle.

WARNING: DO NOT APPLY CONTROL VOLTAGE OR RACK THE BREAKER INTO THE TEST OR CONNECTED POSITIONS WHILE THE SAFETY PINS ARE IN USE.

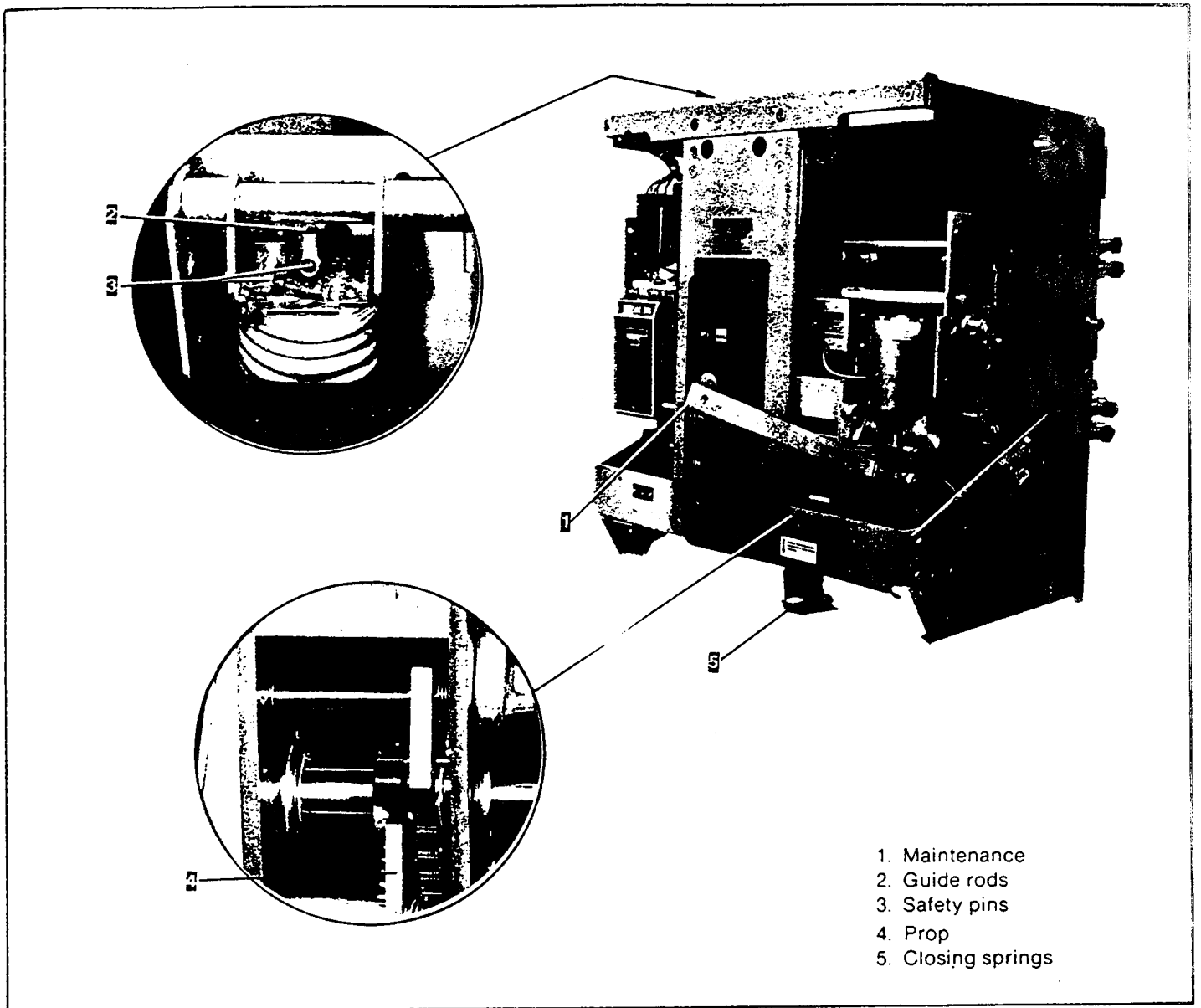

Fig. 7. Installation of safety pin

5.2—Arc Quencher Removal and Inspection

The arc quenchers should be inspected at the regular inspection period. If item 1 is eroded to .125 of an inch from original contour or item 2 is cracked, Fig. 8, the arc quencher should be replaced.

5.2.1—Removal and Replacement

Referring to Fig. 8:

- a. Be sure breaker is open.
- b. Loosen nuts (4) and remove the two slotted head jack screws.
- c. Remove two hex head bolts (5) that mount channel-shaped retaining bar to side support (6).
- d. Remove channel-shaped retaining bar.

(Continued next page)

SECTION 5—Contact Maintenance

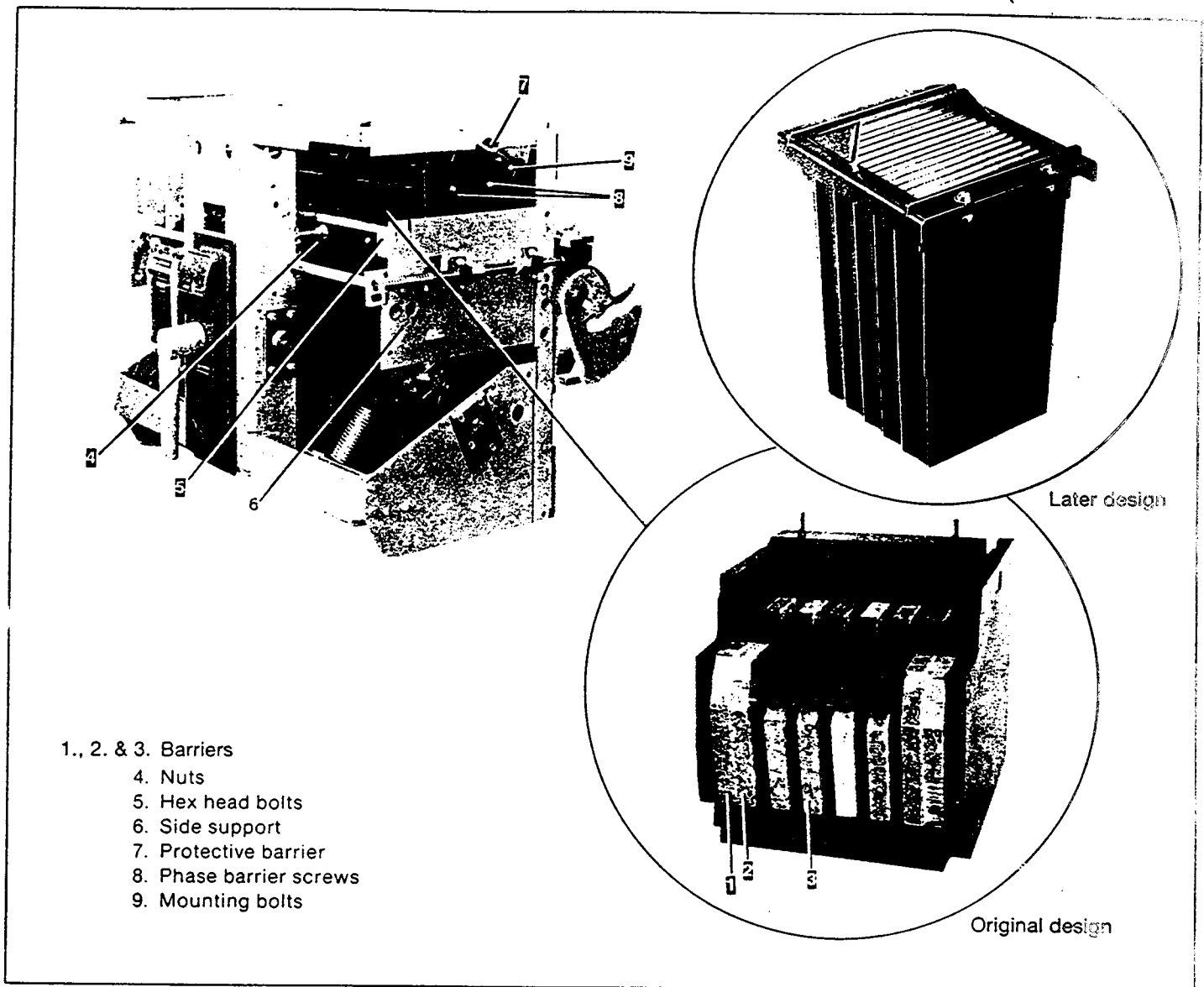

Fig. 8. Arc quencher removal

e. Lift arc quenchers clear of the movable arcing contact arms.

f. Inspect arc quenchers carefully and replace if necessary.

g. During replacement, tighten jack screw nuts (4) first, then the two hex head bolts that secure the channel-shaped retaining bar to side sheet. **DO NOT OVERTIGHTEN THESE TWO BOLTS.**

5.3—Separation of Front and Back Frames

In order to perform some repair and replacement operation, the front frame must be separated from the back frame. Proceed as follows: referring to Fig. 9.

a. Open the breaker, manually compress the closing springs and insert the safety pin as described under **SLOW CLOSING**, Section 5.1. Restraining the springs properly positions the main operating cam to facilitate the separation operation.

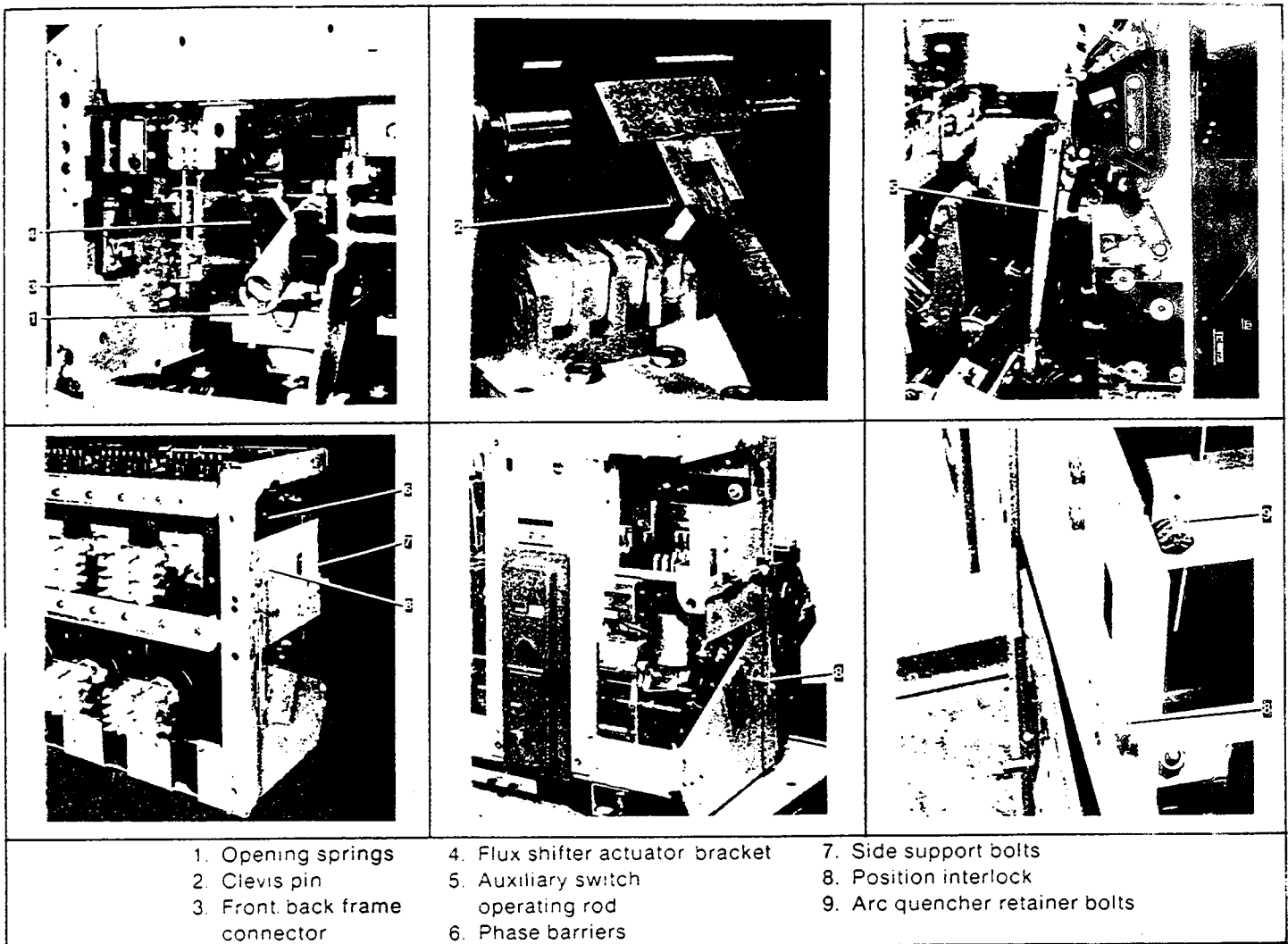

Fig. 9. Front and back frame separation details

b. Remove the two opening springs (1) (on lower part of the breaker) from the outside pole units.

c. Remove the clevis pin (2) from the center pole unit.

d. Disconnect the programmer CT wire harness at each CT and remove any tie wraps holding leads to back frame.

e. Disconnect the flux shifter actuator bracket from the crossbar assembly (4).

f. Remove the auxiliary switch operating rod (5).

g. Remove outside phase barriers (6).

h. Remove side support bolts (7).

i. Remove position interlock on AKD, AKD 5, AKD 6 type (8).

j. Remove arc quencher retainer and bolts (9).

k. Remove the six nuts from the back frame using a socket wrench with an extension. These include the two nuts at the top of the frame.

l. Check along the trip shaft for a mechanical interference or connection between the overcurrent trip device and the trip paddles. Remove mechanical connection if present, or if interference exists, use extreme care when removing or reassembling front and back frames to avoid mechanical breakage of trip devices.

When reassembling the front and back frames, both should be positioned vertically so that the trip shaft is normally aligned. It is recommended that the breaker back frame be fastened to a suitable mounting surface so that the front frame can be supported by a sling or hook as the bolts are being installed.

SECTION 5—Contact Maintenance

5.4—Back Frame Assembly

The breaker backframe consists of a frame assembly to which the pole units are mounted. Each pole unit is connected to a common crossbar which provides for simultaneous pole unit operation by the breakers mechanism. A typical backframe is shown in Fig. 10.

The pole units consist of a molded base which supports the line and load stud assemblies, stationary and moveable contact assemblies and the actuating linkage.

The stationary main contact assembly (9) comprises of a spring loaded contact fingers. Interlocked with these are the intermediate contact fingers (7) whose contact surface project beyond that of the main such that the intermediates make before, and break after the mains.

Mating with the stationary contacts is a moveable contact assembly consisting of multiple main and intermediate contact fingers (10) and (8). These moveable contact fingers pivot on a stationary pin (11), which fasten them to the lower contact block. The insulated link (13) which is attached to the breaker crossbar (1) and moveable contact assembly gives the open and close motion to the contact arm.

The stationary arcing contact assembly (3) is a separate set of contact fingers, pins, springs and pivot block.

The moveable arcing contact assembly (5) consists of multiple contact arms carried on two moveable pins (6) and (12). The arcing contact arms interleave the main contacts and pivot with them about pin (6). This relative motion is obtained by the insulating links (13) from the contact arms to the breaker crossbar.

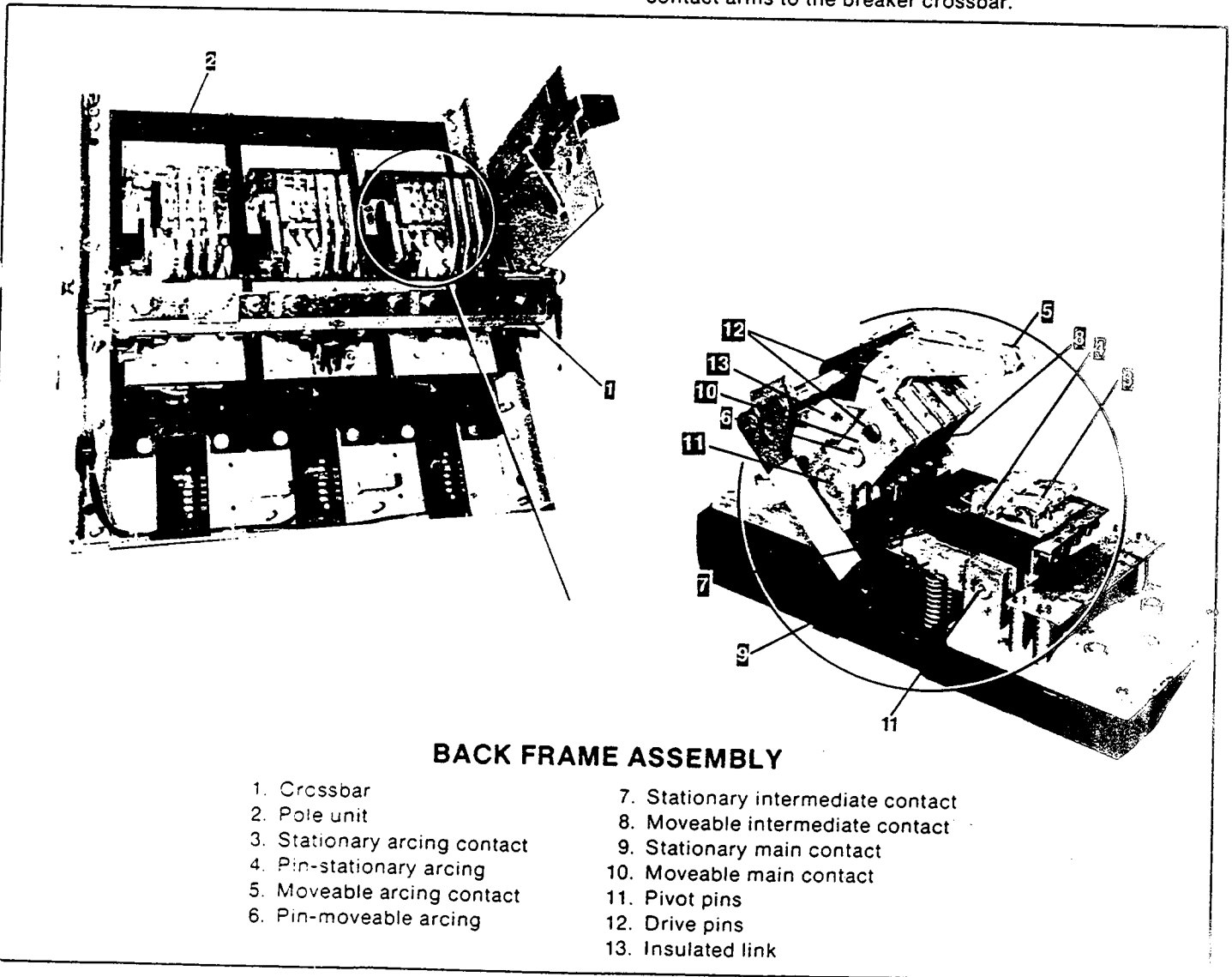

Fig. 10. Front view of back frame assembly

5.5—Measuring Contact Force

- a. Remove the arc quenchers.
- b. Separate front and back frames, refer to Section 5.3
- c. Inspect all contacts for wear and arc erosion and, if necessary, replace (see criteria for replacement, Section 5.10)
- d. Measure contact force only if you replace contact arms.

5.5.1—Stationary Arcing Contacts

Referring to Fig. 11:

Place a push scale on the stationary arcing contact at a point 1-3/16 from the contact pivot and depress that contact 1/4 of an inch. Load on the scale should read within the range listed in Table 6, column 8.

If the load is not within the range listed in column 8, replace the spring under that contact assembly.

5.5.2—Stationary Main and Intermediate Contacts

Place a push scale on the stationary contact at a point 2-7/8 from the contact pivot and depress that contact to the wipe dimension shown in Table 6, column 3 for the mains and column 6 for the intermediates. Load on the scale should read within the range listed in Table 6, column 2 for the mains and column 5 for the intermediates.

If the load is not within the range listed replace the spring under that contact assembly.

5.6—Measuring Contact Wipe

Referring to Fig. 11:

- a. Remove arc quenchers.
- b. With the breaker open measure the horizontal distance from the edge of the stationary arcing contact to the retainer ("A" dim.); for main and intermediate contacts measure the horizontal distance from the top of the contact to the contact arm retainer ("B" dim.).
- c. Close the breaker and repeat step b. The difference between the readings determines the contact wipe.

See Table 6 for correct readings.

CAUTION: FOR SAFETY REASONS BE EXTREMELY CAREFUL NOT TO TRIP THE BREAKER WHEN MEASURING CONTACT WIPE.

5.7—Adjusting Contact Wipe

Referring to Fig. 11:

- a. To obtain proper contact wipe and pressure on the center pole, dimension "C" should be increased to increase wipe and decreased to decrease wipe.
- b. To change dimension "C" remove the clevis pin and rotate the clevis as necessary.
- c. To prevent overstressing the clevis threads dimension "C" should not exceed 3/16 in. and space "C" should be filled with shims to 0.005 in. of being solid.
- d. With the proper center pole wipe obtained, moving the crossbar adjusting plate on the center pole to the right will simultaneously increase the wipe on both outside poles; moving the adjusting plate to the left will have the reverse effect.
- e. To increase the wipe on either outside pole, individually move the crossbar adjusting plate of that pole to the left; to decrease the wipe move the adjusting plate to the right. See Section 5.11.

SECTION 5—Contact Maintenance

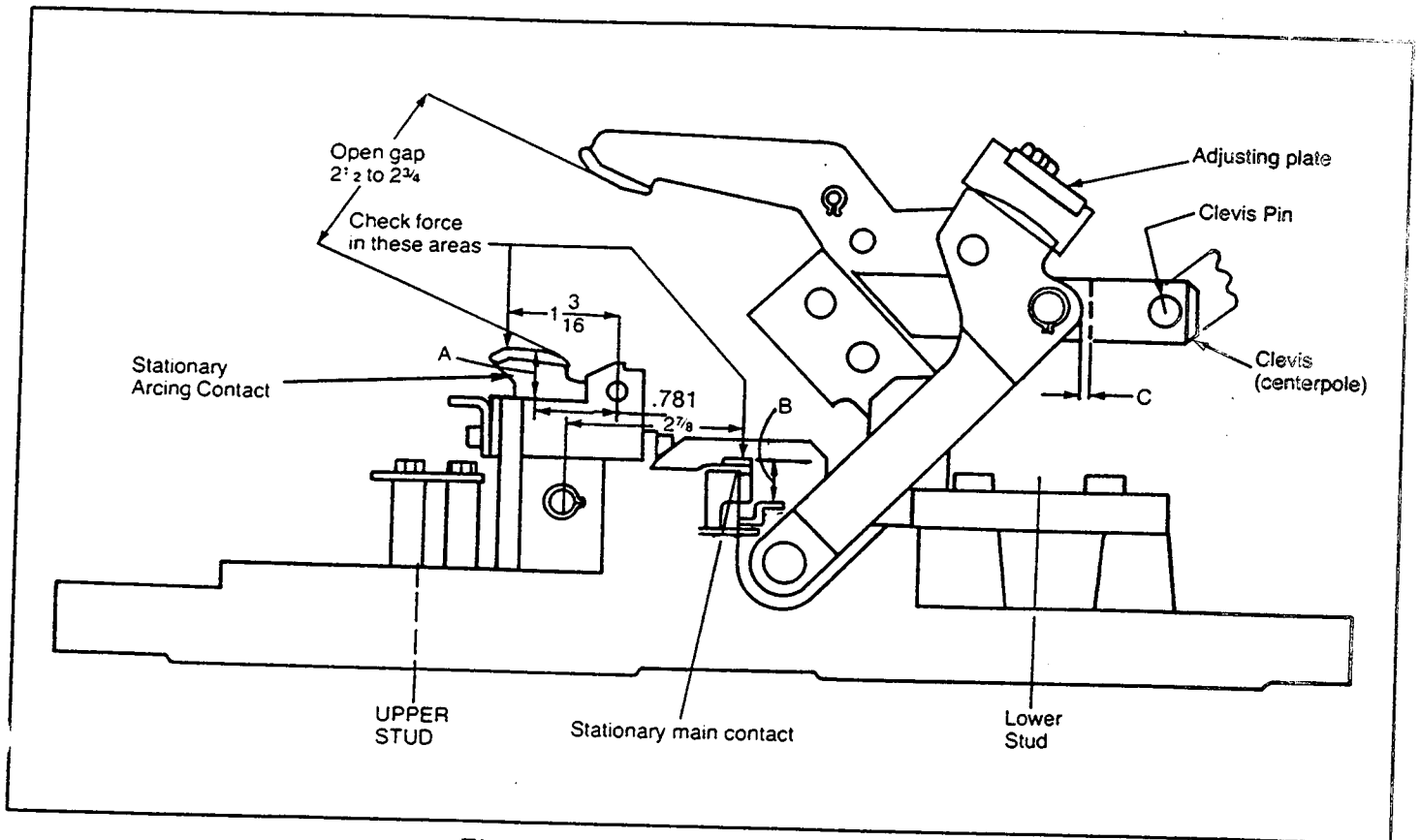

Fig. 11. Measuring contact force

Table 6

Column	Main Contacts			Intermediate Contacts			Arcing Contacts		
	1	2	3	4	5	6	7	8	9
Breaker Type	Qty. Per Pole	Force in Lbs.	Wipe in Inches (B)	Qty. Per Pole	Force in Lbs.	Wipe in Inches (B)	Qty. Per Pole	Force in Lbs.	Wipe in Inches (A)
AKS-50 (AC)	3	35-55	$\frac{1}{16}$ to $\frac{7}{64}$	1	35-55	•	2	31-43	$\frac{5}{32}$ to $\frac{9}{32}$
AKS-50 (DC)	3			1		•	3		
AKR-75 (AC)	5	25-55		1	25-55	•	3		
AKR-75 (DC)	5			1		•	5		
AKR-100 (AC/DC)	6			2		•	5		

*The intermediate contact wipe should be at least $\frac{1}{16}$ in. greater than main contact wipe.

5.8—Measuring Contact Open Gap

Prior to measuring the open gap, verify that the cross arm buffer assemblies, refer to Fig. 12, are touching. The stack-up dimension of each buffer should be within .015" of each other. Adjust to this dimension by adding or removing washers.

Measure the contact open gap between the movable and stationary contacts as shown in Fig. 13. This distance should be between 2-1/2" to 2-3/4". This gap may be adjusted by repositioning shims on crossbar assembly. The locking nuts on the buffer bolts should be locked in such a position that the buffer bolt may be rotated freely.

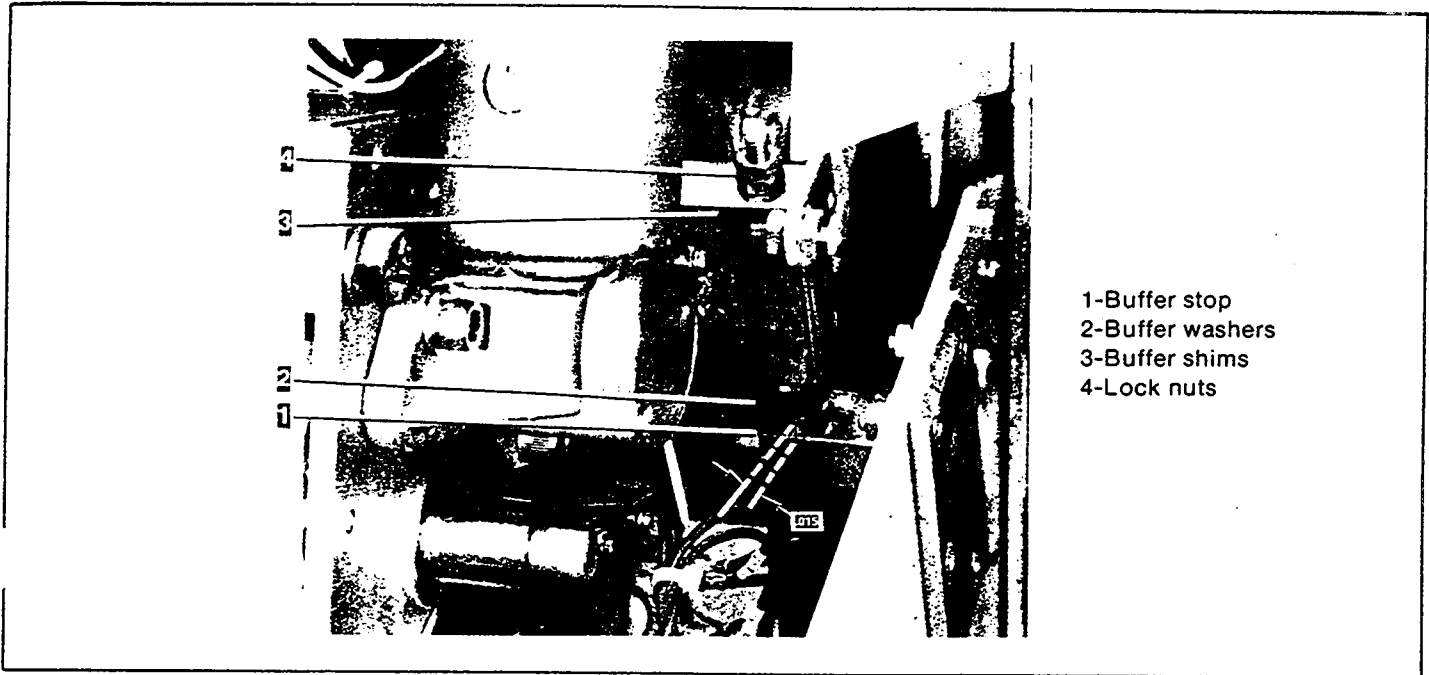

Fig. 12. Buffer assembly

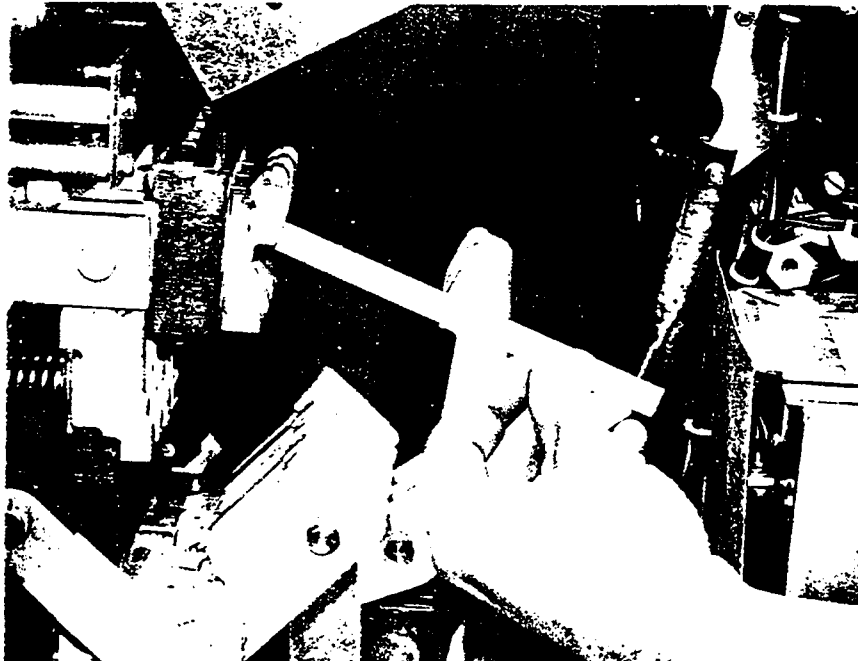

Fig. 13. Measuring contact open gap

SECTION 5—Contact Maintenance

5.9—Checking Contact Sequence

On the horizontal plane, the difference in the making of the arcing contacts on the same pole must be no greater than 1/16 in.; this difference between arcing contacts on separate poles must be 1/16 in. If it is desired to advance or retard the closing of the main contacts of a pole, loosen the bolts holding the adjustment plate, refer to Fig. 21, of that pole and slide plate to the left to advance contact closing, or to the right to retard contact closing. Make this adjustment on the outer poles, using the center pole as a reference. Upon retightening adjustment plate bolts, make sure the locking tabs are turned up around bolt heads, locking the bolts securely in place.

Contact sequence in the vertical plane should be such that when the arcing contacts are just touching, the intermediate contact gap should be at least 3/16 in. and the main contacts gap at least 1/4 in., see Fig. 14.

NOTE: This check can best be made by means of the maintenance handle, with the safety pin restraining the closing springs. See Section 5.1 for this procedure.

If the gap is under the required minimum, it is usually possible to form the arcing contacts and obtain the required dimensions. To form the contacts, place a piece of conduit approximately two feet long, over the contact and form the contact either forward or backward by bending it. If the proper dimensions are still not obtained, the moveable arcing contacts should be replaced.

If it has been necessary to make any adjustments while obtaining proper contact sequence, the contact wipe must be checked, and adjusted, if necessary, see Section 5.6.

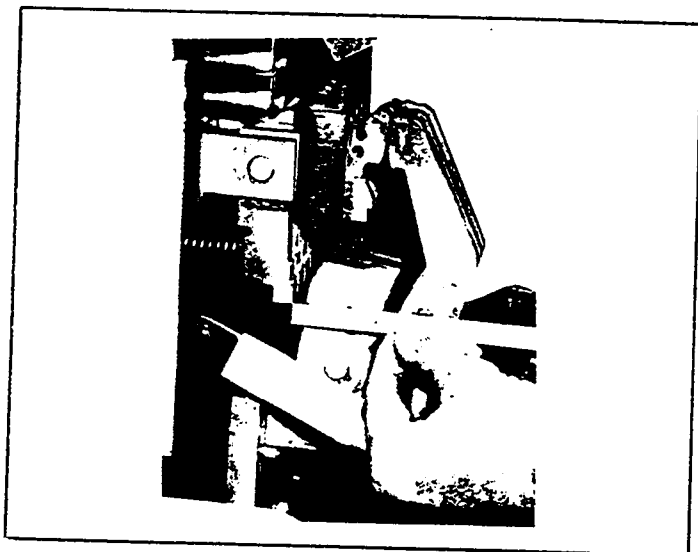

Fig. 14. Measuring main contact gap

5.10—Replacement of Contacts

Criteria for replacement:

- Arcing contacts should be replaced when eroded to a thickness of 5/64.
- Intermediate contacts should be replaced when flush with main contacts (.062 lead when new).
- Main contact very seldom needs replacement. Replace when arcing contacts have been neglected causing severe erosion of mains so you can not obtain proper contact depression.

When replacing the arcing contact assemblies you do not have to separate the front frame from the back frame.

5.10.1—Stationary Arcing Contacts

- Refer to Fig. 15.
- Remove insulator block (1).
- Slide pin (2) to side. Contact assembly (3) will lift freely exposing two springs (4) and button (5).
- Install new parts in reverse order.

5.10.2—Movable Arcing Contacts

These contact arms should be replaced whenever the stationary arcing contacts are replaced.

- Refer to Fig. 15.
- Remove retaining rings (6). Slide pins to side and withdraw the contact arms.

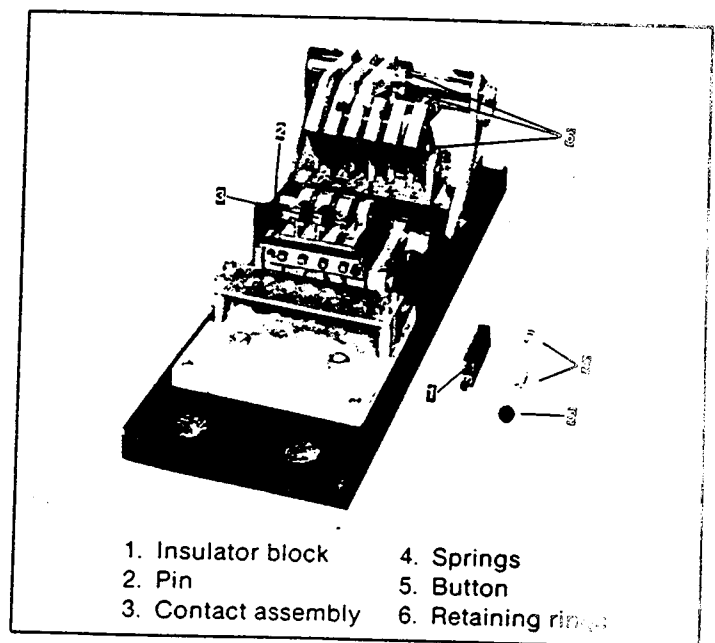

Fig. 15. Replacement of stationary and movable arcing contacts

5.10.3—Moveable Main and Intermediate Contacts

- a. Refer to Fig. 16.
- b. Loosen crossbar bolts so link (10) can move freely.
- c. Remove retaining rings (7) from pins (8).
Slide pins (8) until contact arms can be withdrawn.

d. Remove contact arms, noting two spring washers (9) on each contact pivot.

Upon re-assembly, position two spring washers into counter bore on one side of contact arm (9). Note left and right hand orientation of contact arms and position of intermediate contact.

e. Before tightening crossbar see assembly and adjustment of crossbar, Section 5.11.

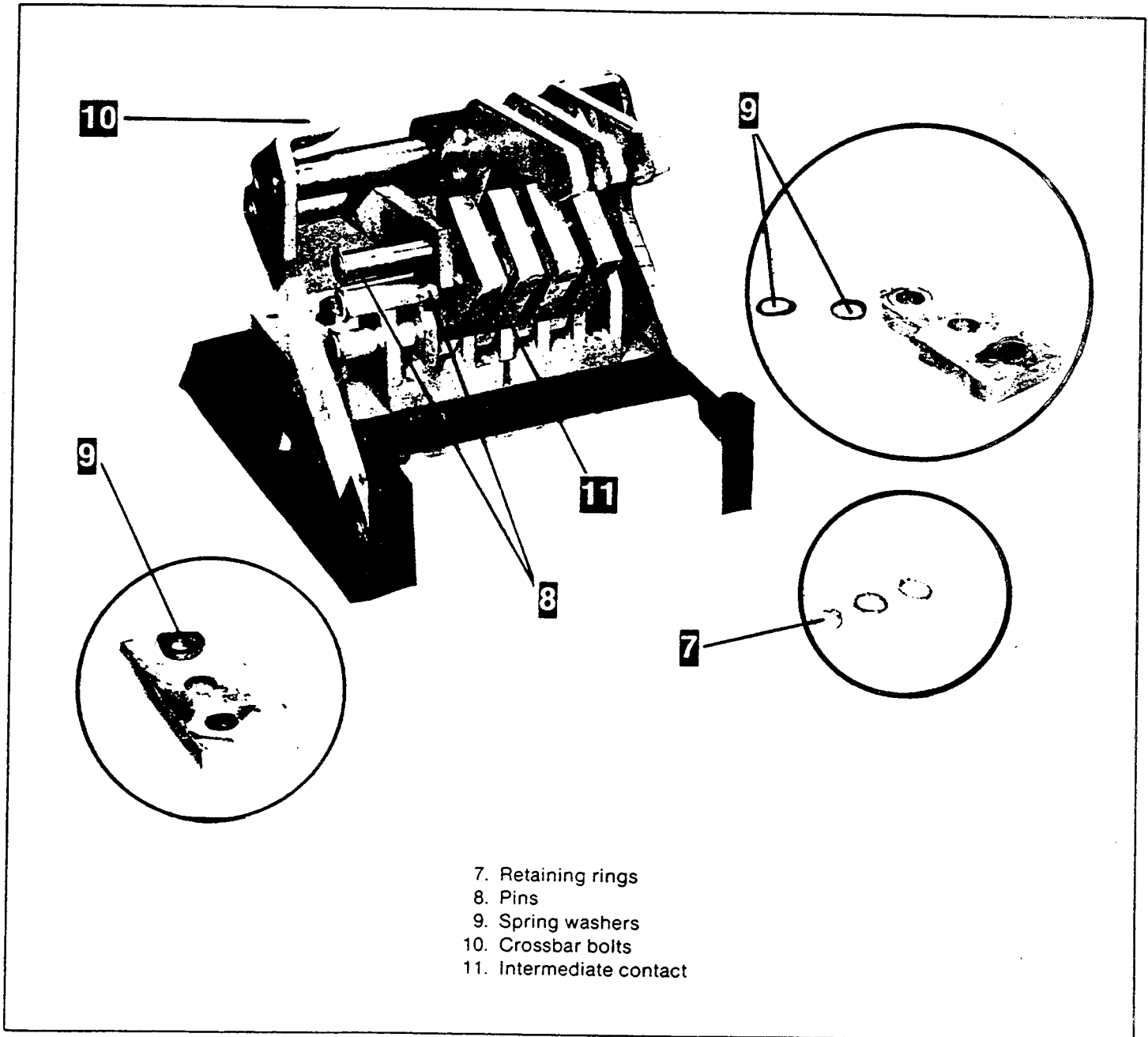

Fig. 16. Replacement of main and intermediate contacts

SECTION 5—Contact Maintenance

5.10.4—Stationary Intermediate and Main Contacts

a. Separate the front frame from the back frame. Refer to Section 5.3.

b. Remove crossbar.

NOTE: In the steps below, refer to Fig. 17 to identify the numbers in the parenthesis.

c. Remove arcing contact block (3) by removing allen screws (4) and (5).

d. Depress main and intermediate contacts as shown in Fig. 18 to relieve spring pressure on contact stop bracket (6) before removing mounting screws. On AKR100 you must remove the outside moveable contact arm before trying to remove contact stop bracket mounting screws.

e. Remove retaining ring (7) and slide pin (8) to side and withdraw the contact arm. Fig. 17.

f. Remove contact, noting two spring washers on each contact pivot. Upon re-assembly, position two spring washers into counter bore on one side of contact arm. Fig. 19.

NOTE: Left and righthand orientation of contact arms and position of intermediate contact. Fig. 19.

g. Depress main and intermediate contacts to relieve spring pressure on contact stop bracket before starting screws. Tighten screws before releasing pressure. Fig. 18.

h. Re-install arcing contact block by holding arcing contacts depressed (Fig. 20) while tightening screws.

i. Assemble crossbar.

j. Always check contact wipe following contact replacement. See Section 5.6.

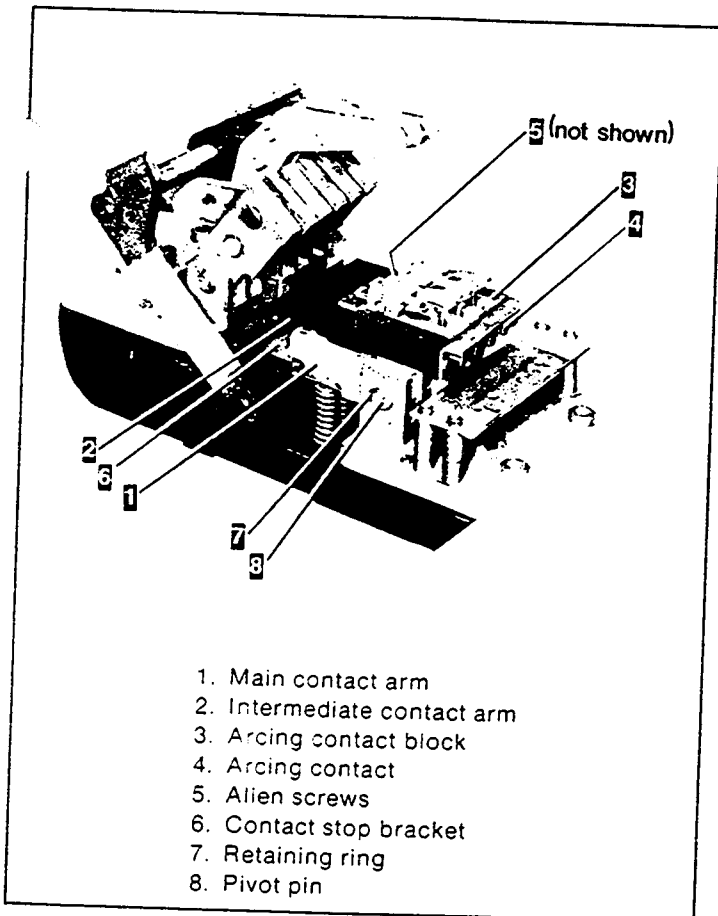

Fig. 17. Intermediate and main contacts - assembly details

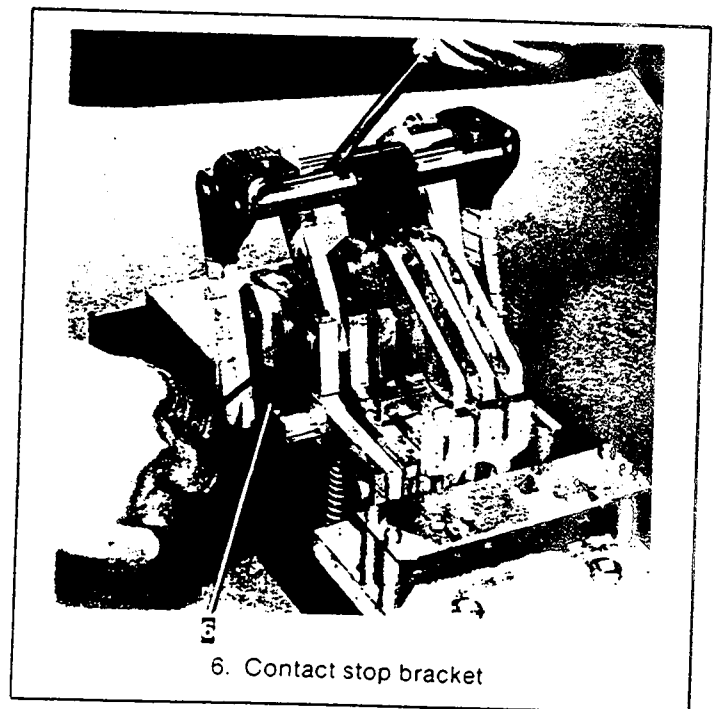

Fig. 18. Relieving spring pressure

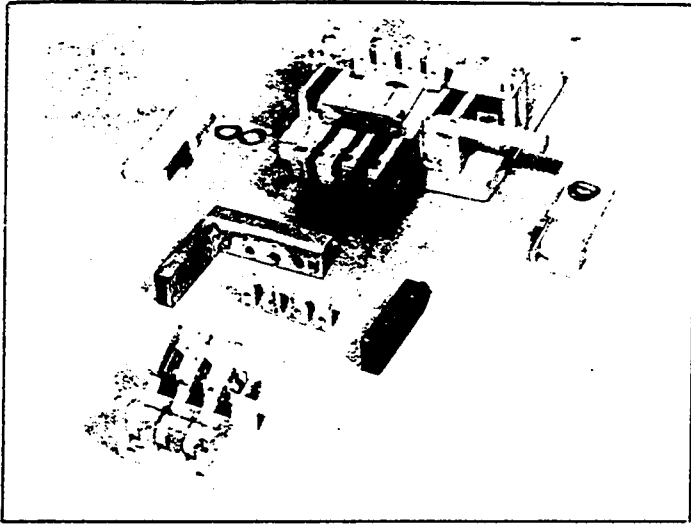

Fig. 19. Upper stud details

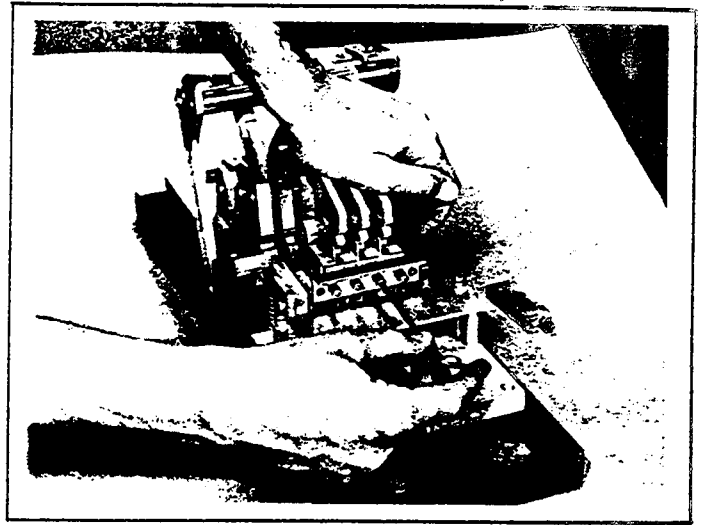

Fig. 20. Re-assembly of arcing contacts

5.11—Assembly and Adjustment of Crossbar

When assembling crossbar to back frame push moveable arcing contacts forward until they touch stationary arcing contacts on upper terminal. Then lay crossbar on top of links on pole units. Assemble adjusting plates as shown making sure slots in plates are properly oriented. Fasten

screws with locking plates on crossbar finger tight and set crossbar to dimension shown making sure that all three poles of moveable arcing contacts are touching stationary arcing contacts within .032. Tighten screws as shown first "A", second "B", and finally "C" to 400 inch pounds. Bend tabs on locking plates to secure screws. Refer to Fig. 21. After assembling crossbar always check contact wipe and open gap, see Sections 5.6 thru 5.8.

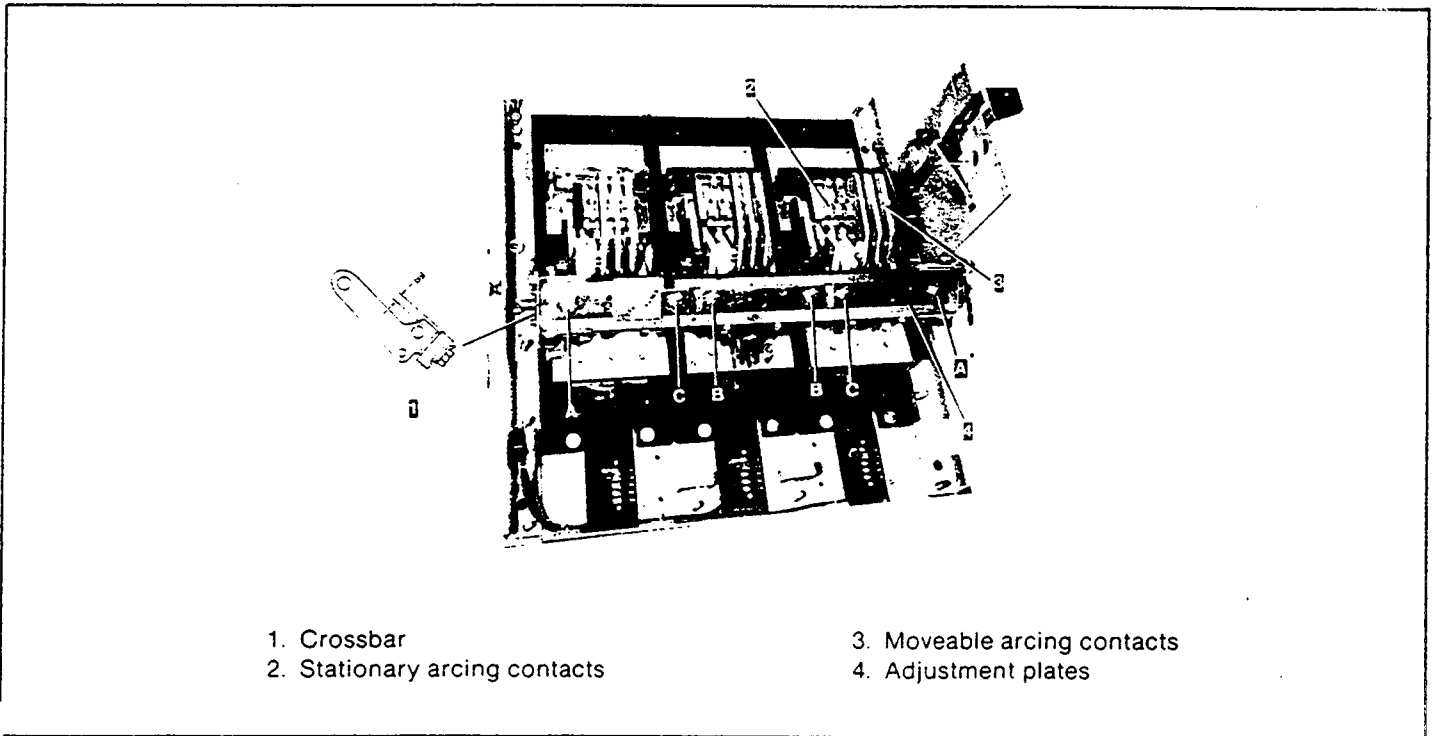

Fig. 21. Crossbar assembly

SECTION 6—Breaker Maintenance

Breaker Maintenance

6.1—Safety Precautions

BEFORE INSPECTION OR ANY MAINTENANCE WORK IS DONE BE SURE THAT THE BREAKER IS IN THE OPEN POSITION. ALL ELECTRICAL POWER, BOTH PRIMARY AND CONTROL SOURCES, SHOULD ALSO BE DISCONNECTED. ENSURE THAT THE CLOSING SPRINGS ARE DISCHARGED.

6.2—Lubrication

In general, the circuit breaker requires moderate lubrication. Bearing points and sliding surfaces should be lubricated at the regular inspection periods with a thin film of GE Lubricant D50HD38 (D6A15A1 Mobilgrease 28). Before lubricating, remove any hardened grease and dirt from latch and bearing surfaces with kerosene. ALL EXCESS LUBRICANT SHOULD BE REMOVED WITH A CLEAN CLOTH TO AVOID ACCUMULATION OF DIRT OR DUST.

NOTE: The use of cotton waste to wipe bearing surfaces should be avoided, as the cotton ravelings may become entangled under the bearing surfaces and destroy the surface of the bearing.

On drawout breakers the contact surface of the disconnect studs should be cleaned and greased with GE Lubricant D50HD38 (D6A15A1 Mobilgrease 28).

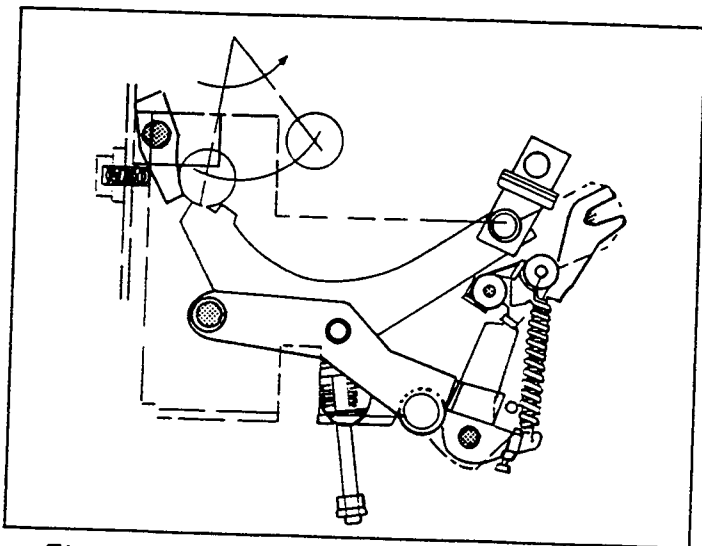

Fig. 22A. Mechanism in motion before resetting as shown in Fig. 22C

6.3—Breaker Mechanism Adjustments

Electric and Manual breakers have the same basic mechanism shown in Fig. 22. All the adjustments detailed below must be made with the breaker in the upright position and the mechanism in the reset position as shown in Fig. 22B. Reset the mechanism by manual operation using the slow close method given in Section 5.1. The roller (15) must be clear of the cam (2), see Fig. 22C.

6.3.1—Trip Latch

Referring to Figs. 22C, 22D & 23, the gap between the trip latch (10) and the roller (9) should be between .015 and .032. This adjustment can be obtained by loosening nut (19) and turning allen screw (6).

6.3.2—Latch Buffer

Referring to Fig. 22D, the center line of the trip latch (10) should pass through the center of the roller (9). The latch buffer (18) on the mechanism frame can be adjusted by loosening the retaining screws to reposition the latch with respect to the roller.

6.3.3—Reset Latch, Bearing and Prop

Referring to Figs. 22C, 22D & 24, the distance between the bearing (17) and the prop (5) should be between .015 and .032. To obtain this gap, advance or retard the nuts (4A) on the bottom of the rod using the reset spring (4).

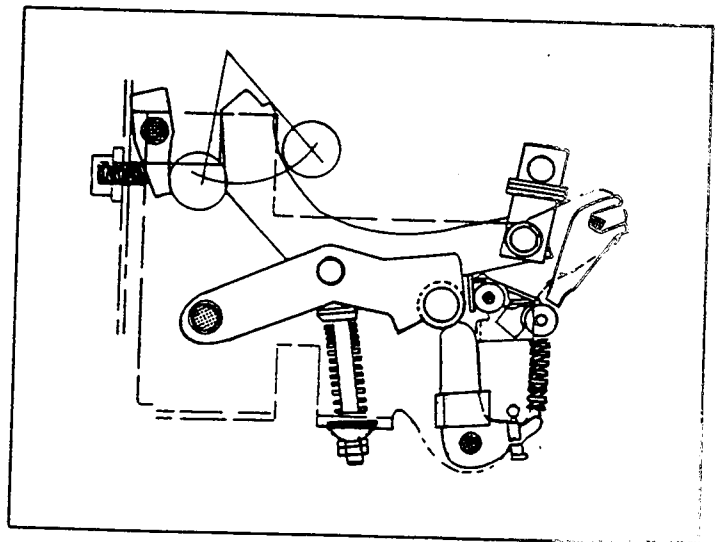

Fig. 22B. Mechanism in reset position

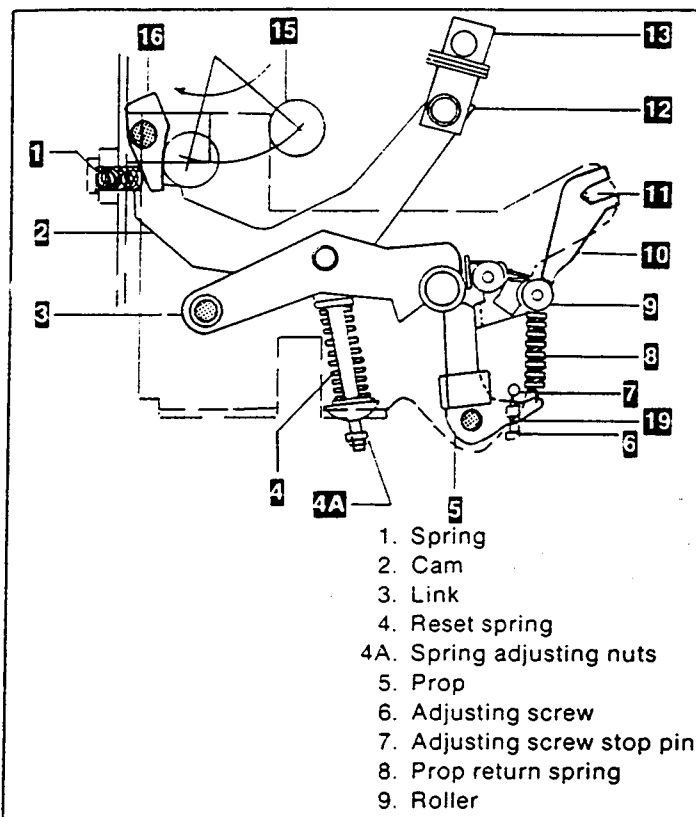

Fig. 22C. Mechanism in closed position (closing spring discharged)

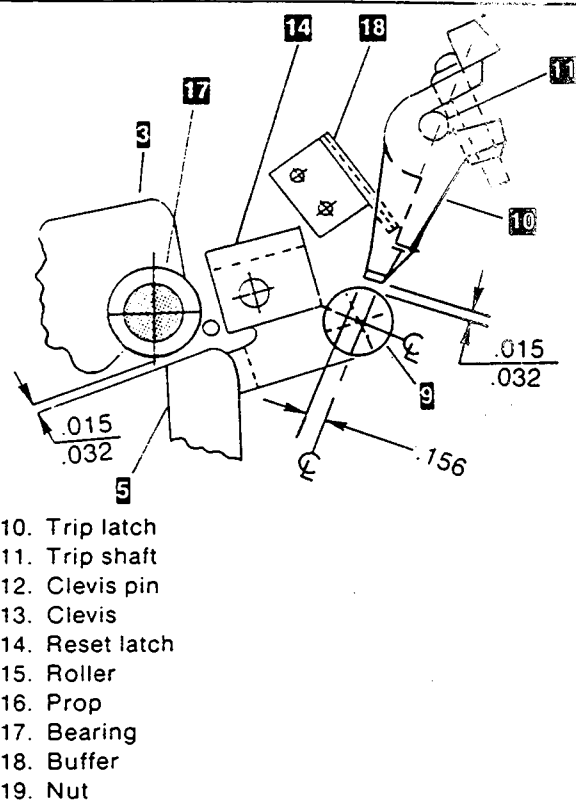

Fig. 22D. Latch, bearing, and prop

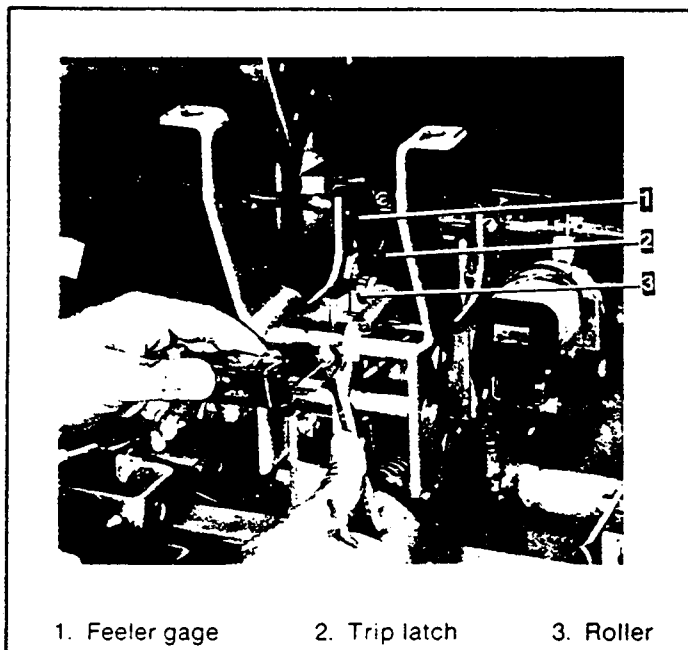

Fig. 23. Adjusting trip latch and roller

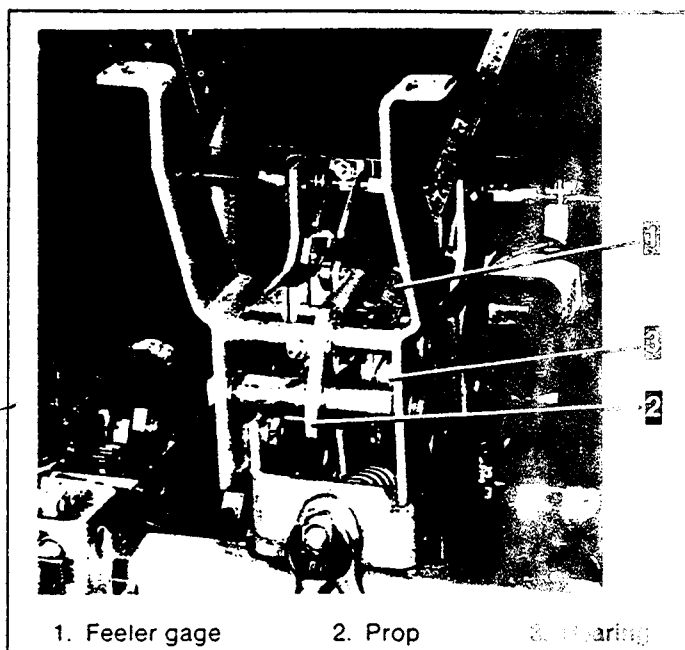

Fig. 24. Adjusting bearing and prop

SECTION 6—Breaker Maintenance

6.4—Electrical Mechanism

The function of the electrical mechanism is to charge and discharge the closing springs either electrically or manually. The electrical mechanism consists of

- a. Control components
- b. Charging motor
- c. Motor operator unit
- d. Spring discharge interlock

Section 4.2 details the associated control circuitry for the electrical mechanism.

6.4.1—Control Components

Referring to Fig. 25:

The control relay (X) is located on the left side of the front frame channel. It may be removed by disconnecting the wiring, loosening the two mounting screws and lifting it slightly to pass the top mounting screw through the keyhole mounting. The entire relay should be replaced rather than changing coils and contacts.

The antipump relay (W) is located on the left side of the front channel. The connections to this relay are soldered. Relay replacement requires unsoldering of these connections and removing the mounting hardware. When replacing relay take care in soldering connections. Do not use excess amount of solder on connectors as to impair operation of contact arms.

The closing solenoid is located in the lower right hand side of the motor operator unit. The switchette is separately mounted in front of the solenoid.

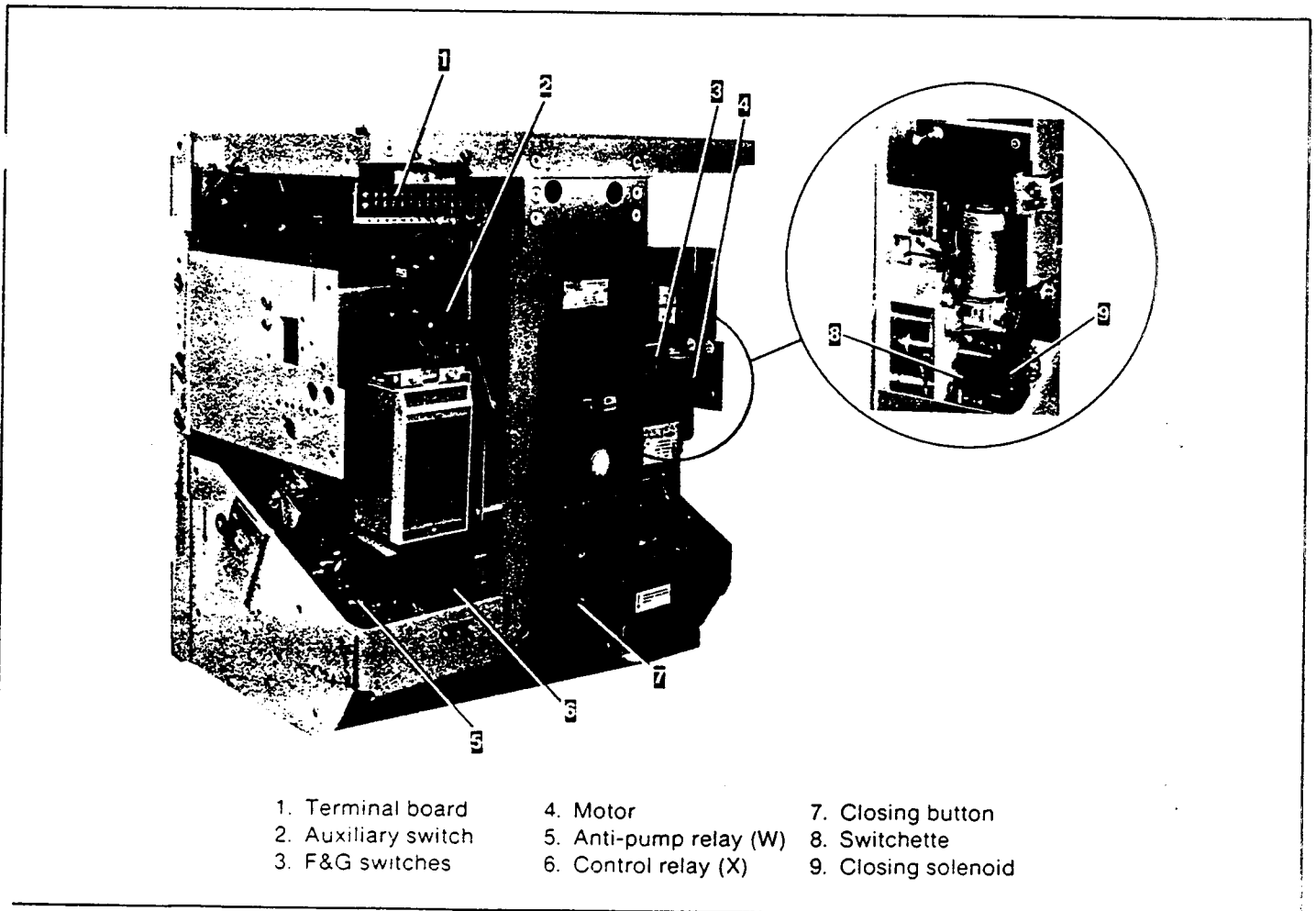

Fig. 25. Control component location

After replacing closing solenoid or switchette check adjustment of switchette and readjust if necessary. With breaker in discharge position use a .010 feeler gage and push closing solenoid to position shown in Fig. 26. Switchette must be activated at this point. To adjust loosen switchette mounting screws and pivot switch until activated, then tighten screws. Recheck.

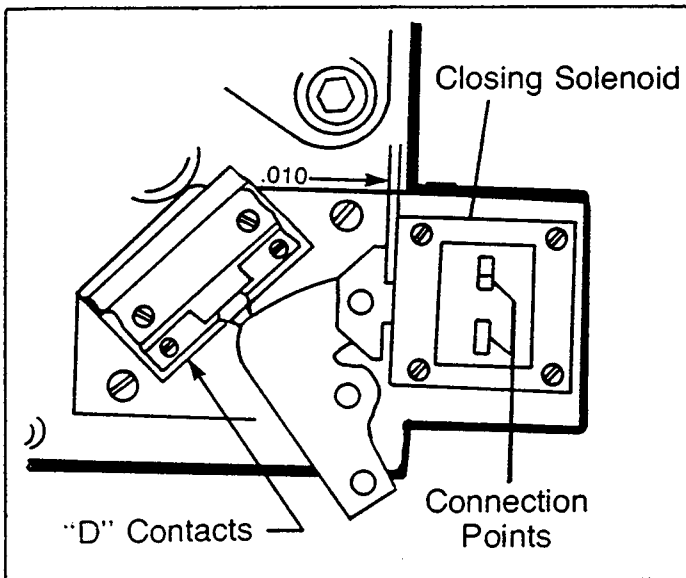

Fig. 26. Switchette adjustment

6.4.2—Charging Motor

The charging motor is located on the right side of the breaker. It is mounted on the motor operator as shown in Fig. 27. A driving pawl is mounted eccentrically on the motor shaft, see Fig. 28. As the motor turns, the driving pawl rotates the ratchet which charges the closing springs. The ratchet is kept from reversing its direction by the holding pawl. To remove the motor:

- a. On AKS 50 you must remove the side sheet.
 - b. Disconnect and identify the motor leads at the closing solenoid and cutoff switch.
 - c. Remove three motor mounting screws.
 - d. Remove motor.
 - e. When reassembling, assemble with the driving pawl pointing toward the front of the breaker.
- See Fig. 28.

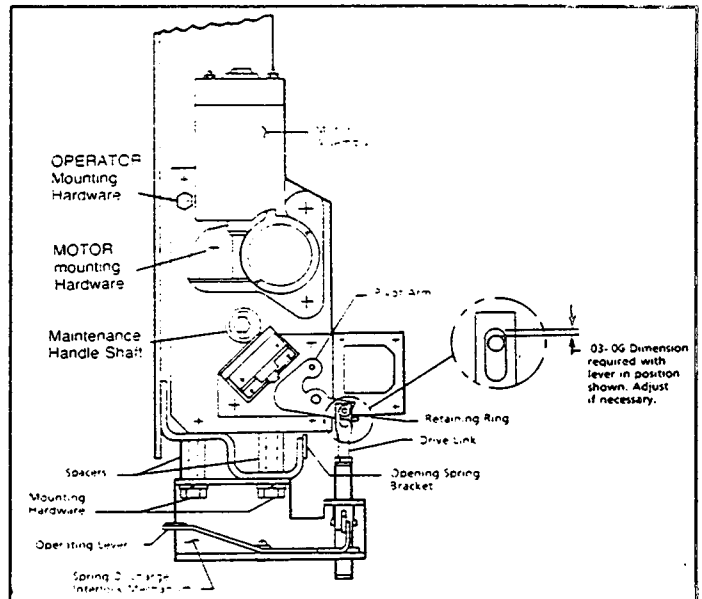

Fig. 27. Electrical mechanism

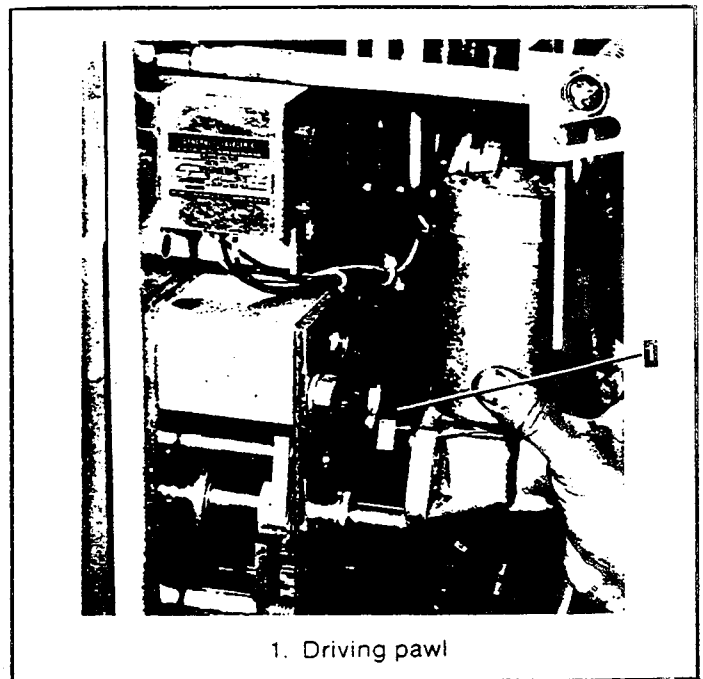

Fig. 28. Motor removal

SECTION 6—Breaker Maintenance

6.4.3—Motor Operator Unit

The motor operator unit is located on the right hand side of the breaker as shown in Fig. 29. Operator details are shown in Fig. 30.

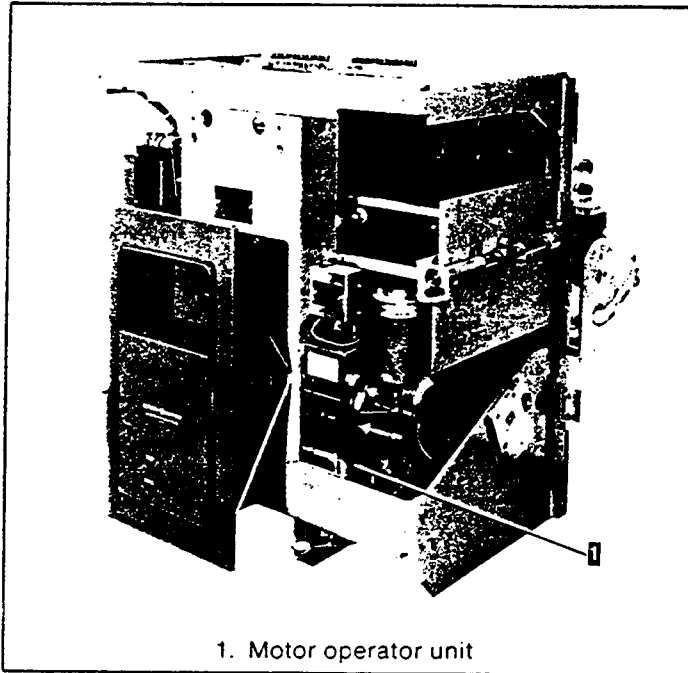

Fig. 29. Motor operator unit location

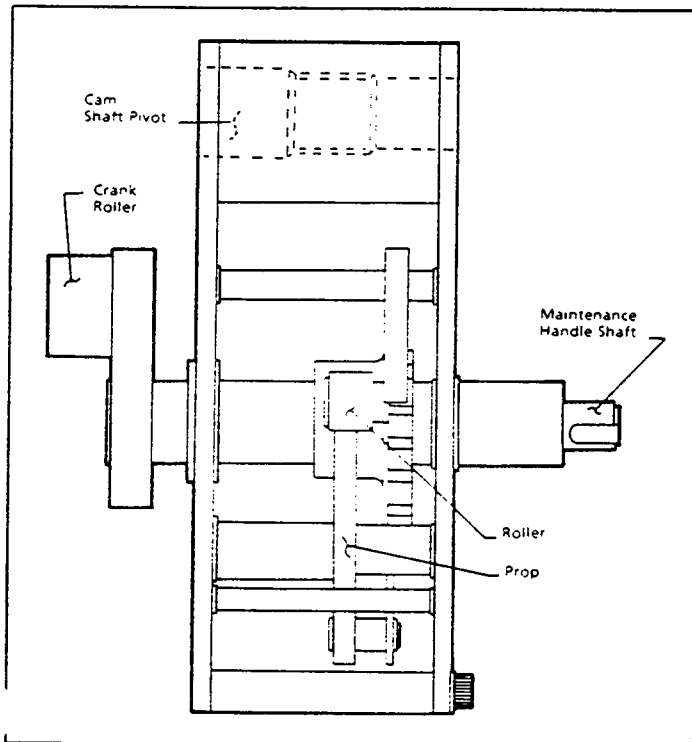

Fig. 30. Motor operator unit

The motor drives the crank roller/maintenance handle shaft until the control circuitry stops the motor and roller is against the prop. The crank roller drives the cam shaft, charging the spring, through the cam shaft paddle, see Fig. 31.

The motor operator unit is not adjustable. To replace the unit, refer to Fig. 27:

- Slow close the breaker, see Section 5.1
- Remove the motor, see Section 6.4.2. The motor wiring doesn't have to be disconnected.
- Disconnect the wiring to the closing solenoid and solenoid switch.
- Remove retaining ring from closing solenoid drive link.
- Remove three mounting bolts, one from the side, two from the bottom of the charging mechanism. Note the positions of the standoffs on the two bottom mounting bolts and replace in the same position when reassembling.
- Rotate motor operator shaft so its crank roller faces the rear of the breaker. Refer to Fig. 32.
- Slide spring charging mechanism out toward the right of the breaker.
- Install new spring charging mechanism making sure the crank roller engages cam shaft guide. Refer to Figs. 31 and 33.

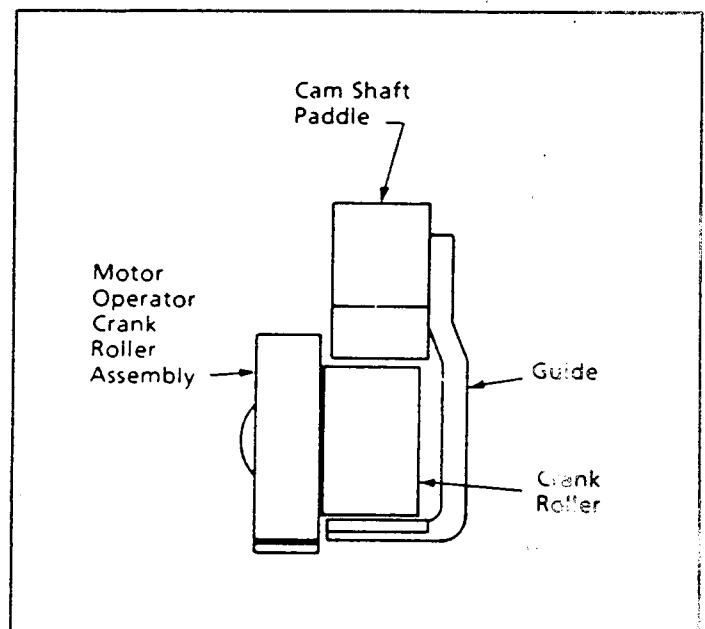

Fig. 31. Engagement of the motor operator crank roller with the cam shaft paddle



Fig. 32. Motor operator removal

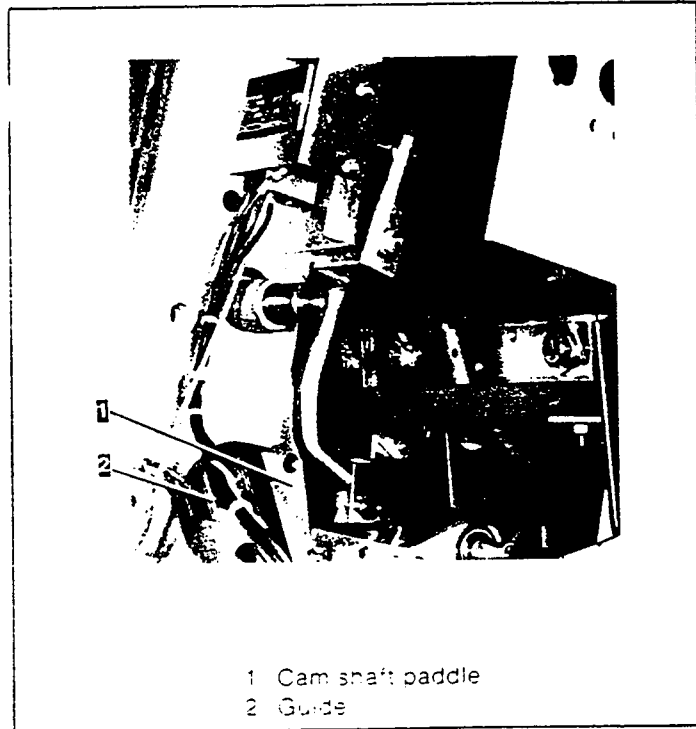

Fig. 33. Cam shaft lever and guide

- i. Reassemble all components and connect all wires.
- j. Remove safety pin from closing spring by placing your maintenance handle on the shaft which extends from the spring charging mechanism and charge the closing spring until the charging mechanism roller engages with the prop. Remove safety pin. This must be done before power is applied to motor.
- k. Operate the breaker using the maintenance handle and spring discharge mechanism a few times. Verify that the breaker is operating properly.
- l. Before applying control voltage to your breaker verify that the motor cut off switches are properly adjusted. Charge the closing spring as described in step j. (roller resting on prop). Adjust the motor cut off switches, shown in Fig. 35, so that they are depressed to the point where the main stem of each switch is located .005" to .031" from the threaded barrel, see Fig. 34.
(Continued next page)

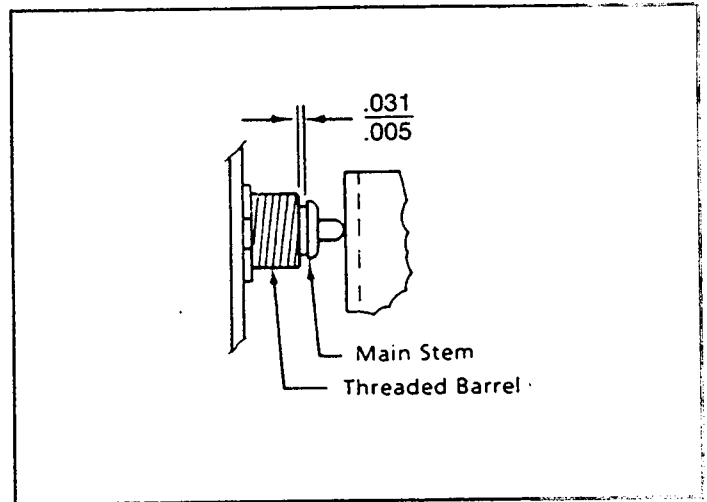

Fig. 34. Motor cutoff switch adjustment

SECTION 6—Breaker Maintenance

6.4.3—Motor Operator Unit (Cont.)

m. When the control voltage is applied to your breaker, the motor operator will be energized and charge the closing spring. The G switch (see Fig. 36) of the motor cut off switch unit will stop the motor operator just before the roller engages the prop. The breaker may be closed manually by depressing the spring discharge lever or electrically by energizing the closing solenoid.

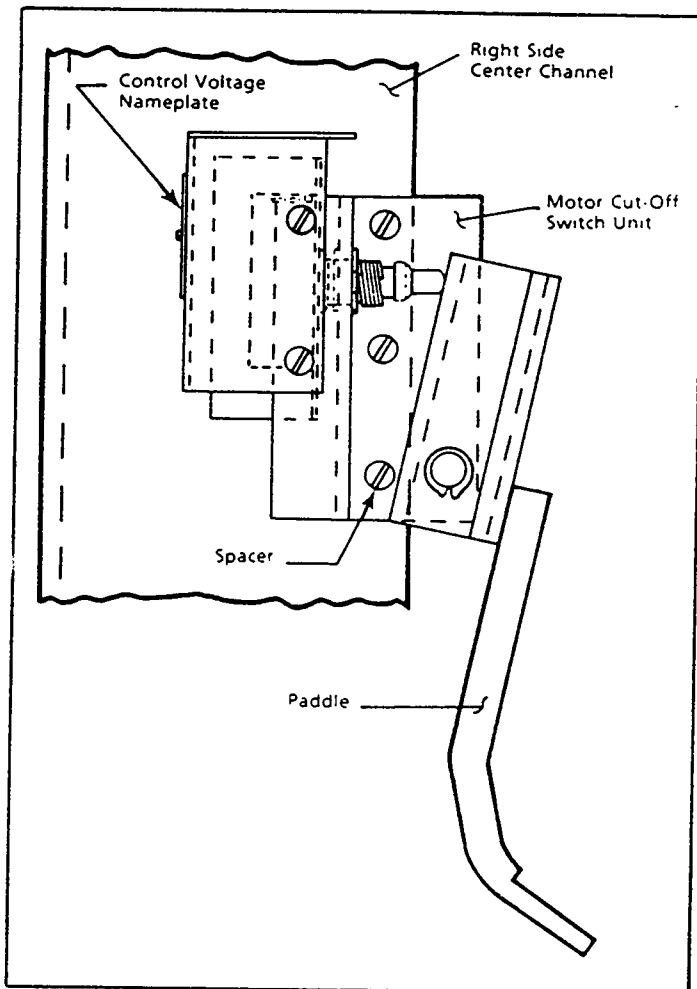

Fig. 35. Motor cutoff switch unit

6.4.4—Spring Discharge Interlock

Referring to Figs. 27 & 30, the spring is discharged when the prop is pulled out from the roller. This is done electrically by the closing solenoid and manually by the spring discharge interlock.

The spring discharge interlock drive link must be adjusted to the .03 to .06 inch dimension shown in Fig. 27. This gap provides the closing solenoid linkage the initial freedom it requires to develop the force necessary to remove the prop.

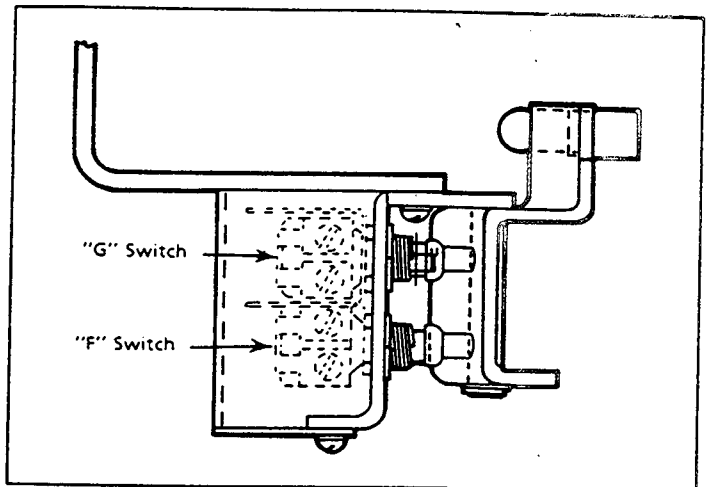

Fig. 36. F & G switch location

6.5—Manual Mechanism

The manual AKR breaker is equipped with the spring-charged, stored-energy mechanism shown in Figs. 37 & 38.

The stored-energy operating mechanism of a manual breaker consists basically of a closing spring assembly, ratchet wheel and output crank assembly, handle shaft and pawl assembly, and the escutcheon-mounted closing handle.

The closing springs (5) are charged by operating the manual closing handle (22) on the front of the breaker, instead of the closing motor as is the case with the electrical breaker. Closing this breaker is accomplished by pumping the operating handle four complete cycles, first counterclockwise through 120 degrees from its normal vertical position and then clockwise back through 120 degrees from its normal vertical position and then clockwise back through 120 degrees. When approximately 70 degrees of the fourth clockwise stroke have been completed, the closing springs, which have been charged during the previous strokes to the closing handle, are driven over-center and the breaker closes.

The first stroke of the closing handle causes the ratchet pawls (21) attached to the handle shaft (23), to engage the first tooth of the ratchet wheel (17), thus beginning to charge the closing springs. The subsequent closing handle strokes perform the same function as the pawls (21) engage the teeth in the ratchet wheel (17), thus rotating the ratchet wheel and output crank (32) and completely charging the closing springs. This rotation of the ratchet wheel and output crank is in a counterclockwise direction from the lower position, through slightly more than 180 degrees, to a position just beyond dead center. In this position the closing springs are free to release their energy, closing the breaker at a high speed.

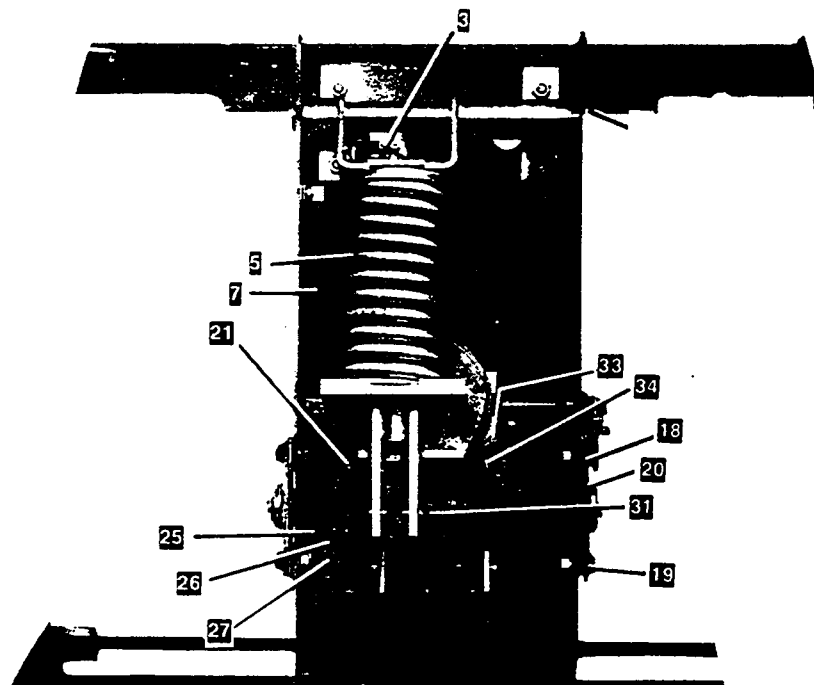

- | | |
|-------------------------------|-------------------------|
| 1. Upper spring pin | 21. Ratchet pawls |
| 3. Safety pin and chain | 25. Main closing crank |
| 5. Closing springs | 26. Pawl buffer stop |
| 7. Pawl springs | 27. Buffer stop shims |
| 18. side plate shims | 31. Lower spring pin |
| 19. Side plate mounting bolts | 33. Ant. rebound spring |
| 20. Bearing side plate | 34. Ant. rebound pawl |

Fig. 37. Manual closing mechanism

6.5.1—Mechanism Part Replacement

If it is necessary to replace any of the mechanism parts, the following total procedure is recommended. This procedure may be halted at the step required to replace any particular part. Referring to Figs. 37 & 38:

- a. Install the safety pin (3) as described in Section 5.1.2.
- b. Remove the closing spring assembly by removing the upper and lower spring pins (1,31).
- c. Remove the right hand bearing side plate (20), and the side plate shims (18) by removing four mounting bolts (19), thus allowing the main closing crank (25) to be removed.
- d. Remove the closing handle (22) by removing two set screws threaded in same hole.
- e. Remove the front escutcheon by removing four screws holding it to the front frame center support.
- f. Remove handle shaft extension by removing roll pin.
- g. Remove the handle return spring (29) by unhooking either end of the spring.
- h. Disconnect the top end of each pawl spring (7).
- i. Remove the roll pin (24), thus allowing the closing handle shaft and pawl assembly (23) to be removed.
- j. Remove the ratchet wheel (17) and its assembly (10) by removing self locking screw (15) and thrust bearing (12). If shims (13) are present they must also be removed.

(Continued next page)

SECTION 6—Breaker Maintenance

MANUAL MECHANISM

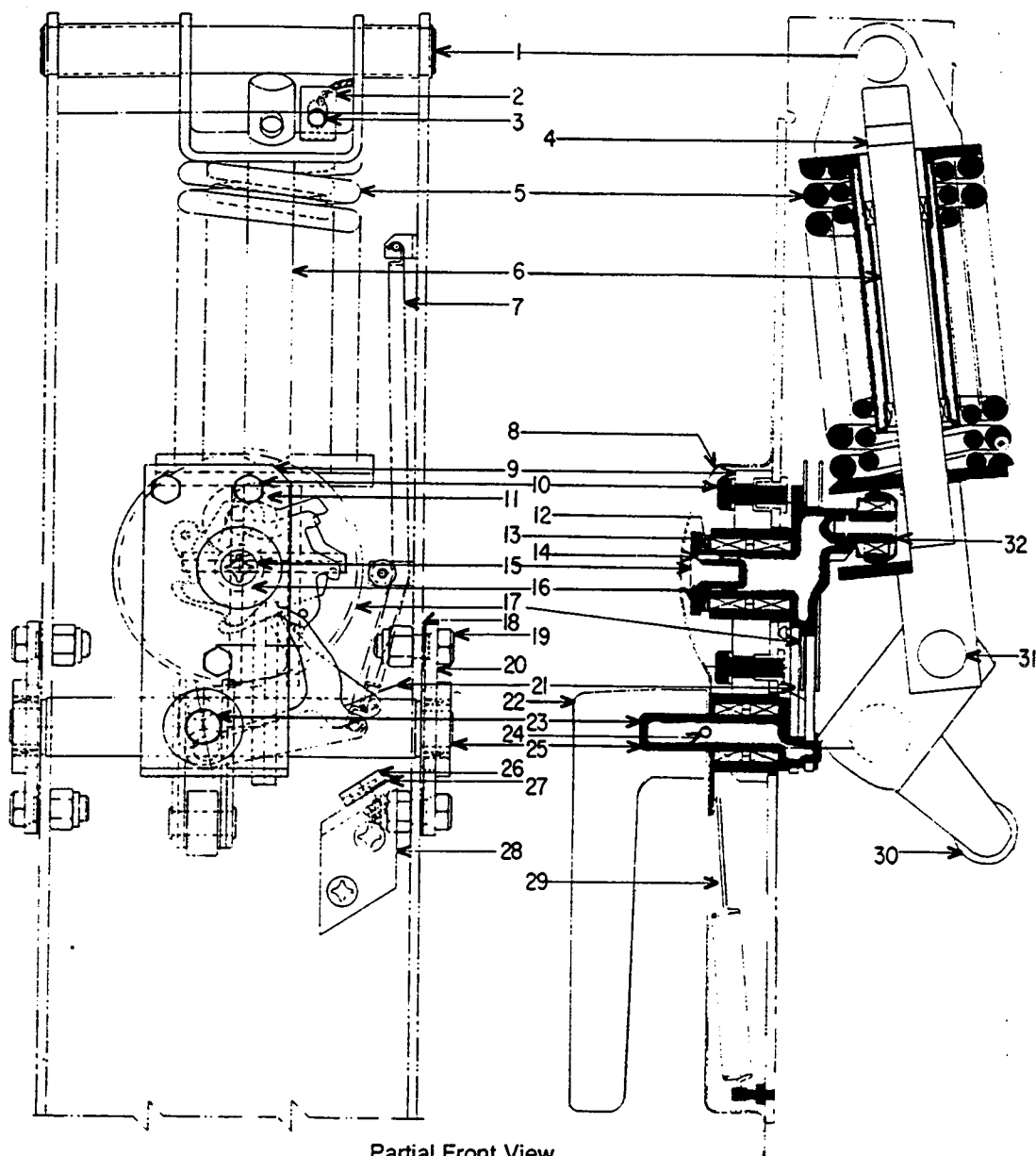

Partial Front View
With Handle And Escutcheon Removed

- | | | |
|----------------------------------|--|--------------------------|
| 1. Upper Spring Pin | 12. Thrust Bearing | 24. Roll Pin |
| 2. Safety Pin Holder | 13. Shims | 25. Main Closing Crank |
| 3. Safety Pin and Chain | 14. Groove Pin | 26. Pawl Buffer Stop |
| 4. Safety Pin Hole | 15. Nylok Screw | 27. Buffer Stop Shims |
| 5. Closing Springs | 16. Ratchet Wheel Shaft and Asm. | 28. Buffer Stop Support |
| 6. Guide Rod | 17. Ratchet Wheel | 29. Handle Return Spring |
| 7. Pawl Springs | 18. Side Plate Shims | 30. Mechanism Roller |
| 8. Front Escutcheon | 19. Side Plate Mounting Bolts | 31. Lower Spring Pin |
| 9. Front Bearing Plate | 20. Bearing Side Plate | 32. Output Crank |
| 10. Bearing Plate Mounting Bolts | 21. Ratchet Pawls | 33. Ant. Rebound Spring |
| 11. Output Crank Roller | 22. Manual Closing Handle | 34. Ant. Rebound Pawl |
| | 23. Closing Handle Shaft and Pawl Asm. | |

Fig. 38. Manual closing mechanism charged position

k. Remove front bearing plate (9) by removing mounting bolts (10) accessible from the front of the breaker. The mechanism is now completely disassembled. It is not recommended that any of the subassemblies removed during the above operation be further disassembled in the field. Replacement sub-assemblies should be obtained from the factory.

l. To reassemble the mechanism, reverse the procedure described above and follow the adjustments given in Section 6.5.3.

6.5.2—Ratchet Pawl Replacement

The manual mechanism is inoperable with broken ratchet pawls. Therefore, the safety pin probably can't be inserted into the guide rod. If this is the case, the following procedure is used to replace the ratchet pawls. Refer to Figs. 37 & 38:

a. Remove upper spring pin (1) by removing retainer ring and pushing pin through front channel and spring support. Closing spring will discharge. Remove individual closing springs. Remove lower spring pin (31) and remaining part of spring support. When replacing closing spring assembly, a new assembly is required or reassembly of the existing parts using a pressing means.

b. Remove the left or right hand bearing side plate (20) and the side plate shims (18) by removing four mounting bolts (19), thus allowing the main closing crank (25) to be removed.

c. Remove anti-rebound pawl (34) by removing retaining ring (36) shown in Fig. 39 and spring (33).

d. Remove retaining ring (35, Fig. 40). Disconnect springs (7) remove buffer stop (26). Both pawls can now be removed. See Fig. 40. When reassembling, verify that retaining ring (36) is properly seated.

e. After replacing parts and before adding closing spring check adjustments given in Section 6.5.3.

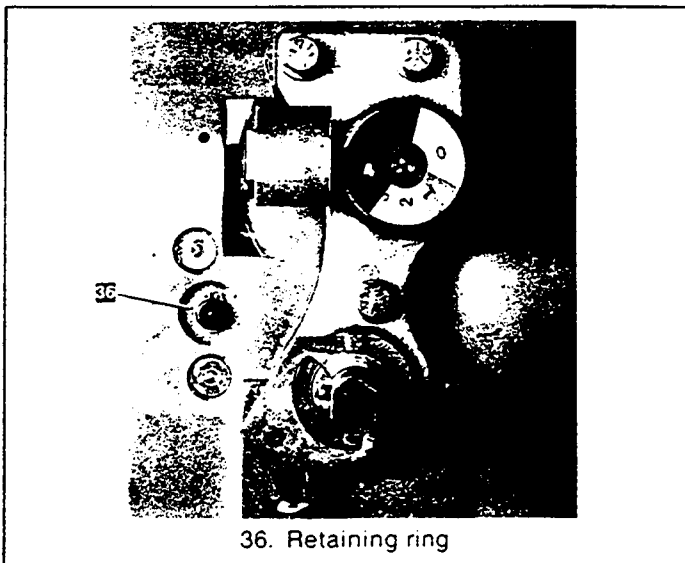

36. Retaining ring

Fig. 39. Anti rebound pawl removal

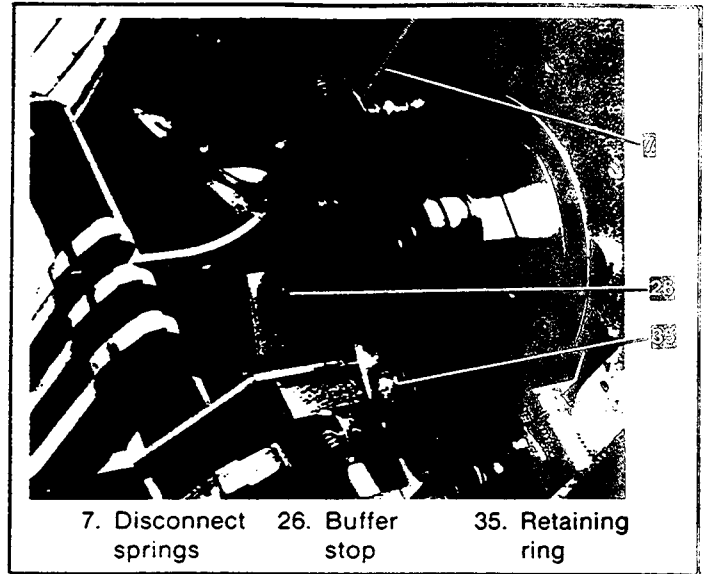

7. Disconnect springs 26. Buffer stop 35. Retaining ring

Fig. 40. Ratchet pawl removal

6.5.3—Adjustments

Frequent adjustments to the mechanism should not be required. If the mechanism has been disassembled, it will be necessary to check the following adjustments:

1. It may be necessary to add shims (13) to reduce the end play of the ratchet wheel shaft (16). An end play of 0.010 to 0.020 inch is recommended. Shims should be obtained from the factory.

2. It may be necessary to add buffer stop shims (27) to the buffer stop (26) to provide a clearance of 1/64 to 1/32 inch between the pawls (21) and the buffer stop, when the pawls are touching the ratchet wheel teeth extending a maximum distance from the center of rotation of the ratchet wheel (17). This measurement should be made while operating the closing handle during the four spring charging operations and before the closing springs are reassembled.

3. The ratchet pawls (21) should operate freely throughout the closing strokes. They should engage the ratchet wheel teeth near the end of each counterclockwise and clockwise stroke of the closing handle with a definite clicking sound, indicating a free non-binding operation. After the clicking sound is detected, the closing handle should have a minimum overtravel of 1/2 in. or 3 1/2 degrees, measured at the end of each handle stroke. At the end of the four stroke the rebound stop (34) must move into place to properly position the ratchet wheel.

4. The groove pin (14) in the front of the ratchet wheel assembly (16) must be assembled in a manner that will allow screw (15) to be tightened securely. A clearance of 1/64 to 1/32 in. should exist between the front of the groove pin and the rear surface of the screw head.

SECTION 6—Breaker Maintenance

6.6—Drawout Mechanism

Drawout breakers are manufactured in five different styles depending on the type of equipment that the breaker will be used in. The mounting code and description of each style is found in GEI-86151 furnished with each breaker. If replacement of racking cam is needed the following procedure should be used. See fig. 41.

- a. Remove nut (1) and screw (2).
- b. Loosen set screws in collar (3).

- c. Remove racking cam assembly and replace with new cam.

- d. Align center of worm with worm gear on racking cam then position collars firm against supports and tighten set screws in collars.

To replace guide support (4):

- a. Remove screws (5) and support (6).
- b. Remove guide (4) and replace with new guide.
- c. Reassemble.

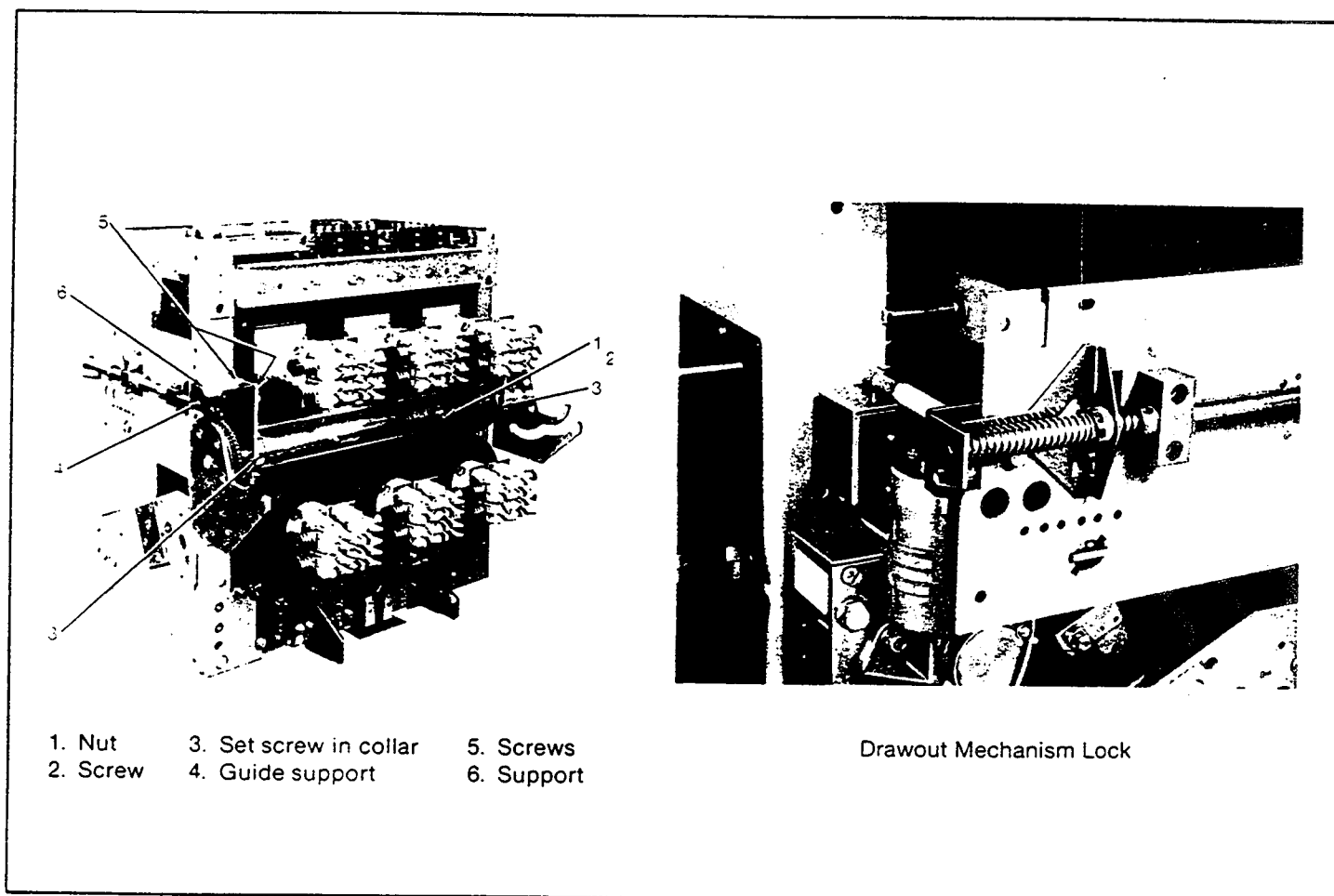

Fig. 41. Drawout mechanism

6.7—Drawout Mechanism Lock

Breakers manufactured after January, 1993 have a locking device installed on the drawout mechanism shaft, Fig. 41. This device provides a stop to prevent the shaft from rotating unless the interlock slide is depressed by the drawout wrench. The racking handle cover plate when depressed, releases a pin on the shaft allowing it to rotate.

SECTION 7—Accessories

7.1—Primary Disconnects

Primary disconnects are found only on drawout breakers. They provide the flexible connection between the breaker line and load terminals and the equipment line and load terminals.

7.1.1—AKR 75/100

There are two types of primary disconnects found on the AKR 75/100 breakers.

Fig. 42 shows the tubular type primary stud used on replacement breakers for the older AKD, AKD5, AKD6 switchgear. If for any reason the primary stud must be

replaced or removed simply disassemble nut and bolt arrangement that is crisscrossed through the tubular stud. When reassembling mounting hardware apply equal amounts of torque to nuts, so distortion to tubular mounting stud does not occur. Torque nuts between 250 to 300 in lbs.

Fig. 43 shows the finger type disconnect assembly used on AKD-6, AKD-8 switchgear and substructure type breakers. If replacement of primary finger is needed, you must replace complete subassembly set of fingers, which are factory adjusted to proper spring tension. Reassemble as described above. See renewal parts publication GEF-4552 for proper ordering data.

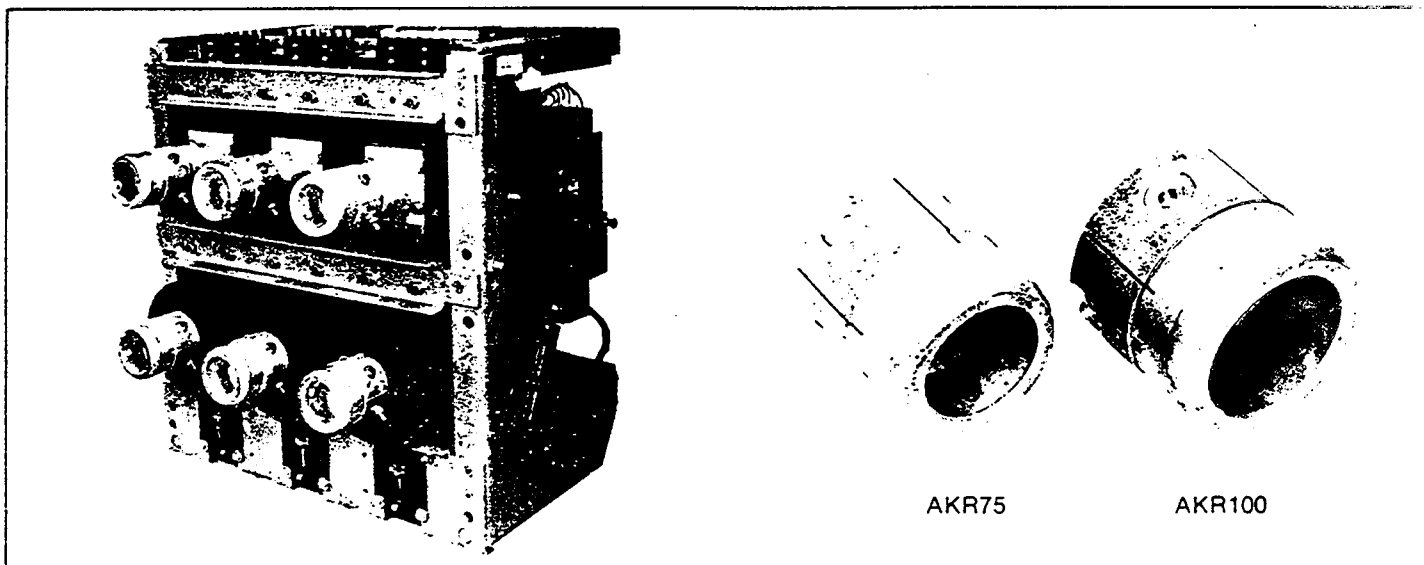

Fig. 42. Tubular type disconnects

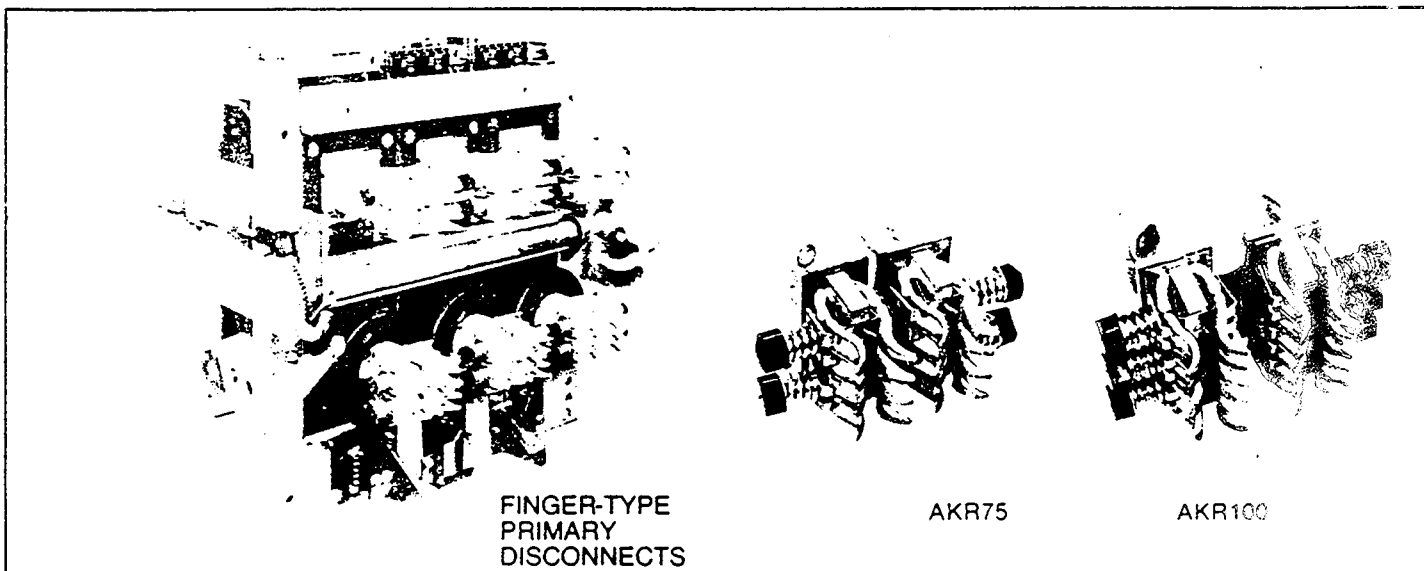

Fig. 43. Finger type disconnects

SECTION 7—Accessories

7.1.2—AKS/AKST 50

The AKS 50 and AKST 50 use eight primary fingers per phase as shown in Figs. 44 thru 47. Refer to these illustrations when replacing the disconnects. Note the following details:

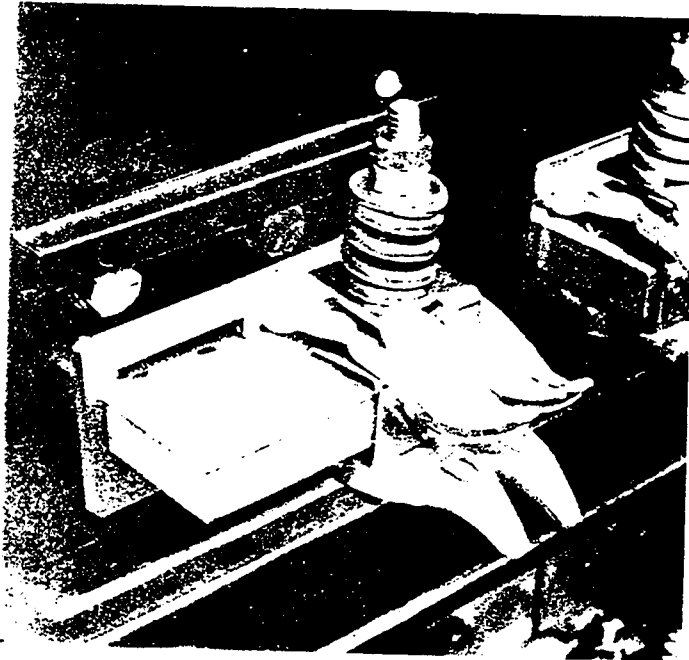

Fig. 44. Primary disconnect assembly



Fig. 45. Partial primary disconnect ASM

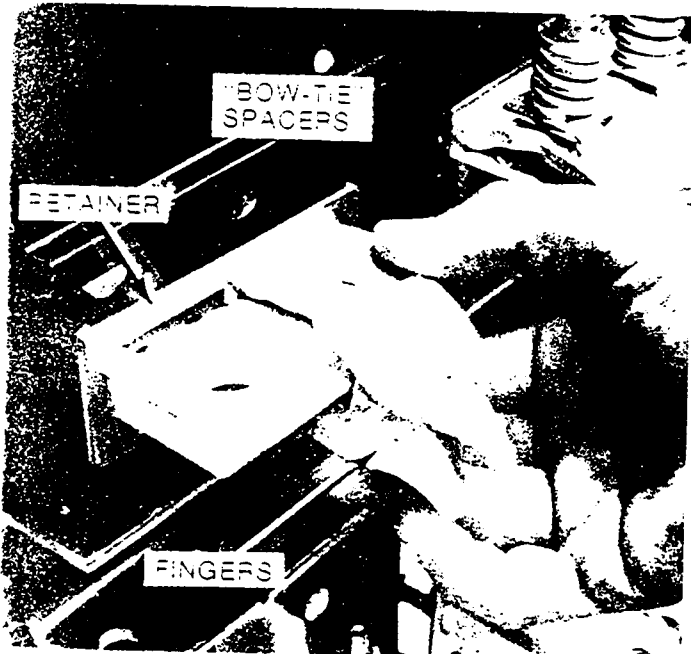

Fig. 46. Partial primary disconnect ASM

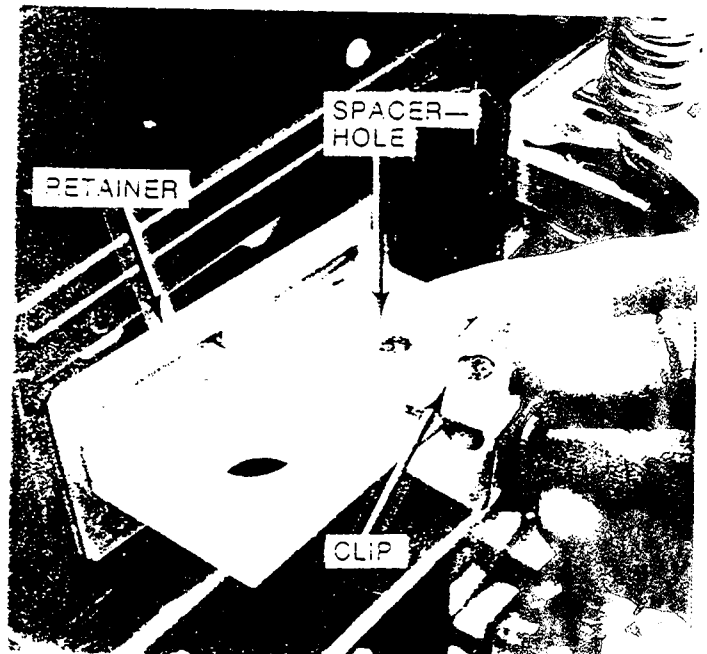

Fig. 47. Partial primary disconnect ASM

Fig. 47—The position of the spacer in the breaker stud. The hole in the spacer must be positioned as shown so it will align with the holes in the clip.

Fig. 46—The engagement of the fingers with the retainer. Also the location of the "bow-tie" spacers in the fingers, both upper and lower.

(Continued next page)

Fig. 44 & 45—The position of the upper and lower retainers and, again, the 'bowtie' spacers.

The primary disconnect assembly is factory adjusted to apply a force of 85-105 pounds on a 1/2 thick copper bar inserted between the upper and lower fingers. After installation of the disconnect assembly this force range is obtained by tightening the locknuts to set the dimension shown in Fig. 48. Note that this dimension is measured between the top of the retainer and the underside of the washer. Also note that no bar is inserted between the fingers when setting this dimension.

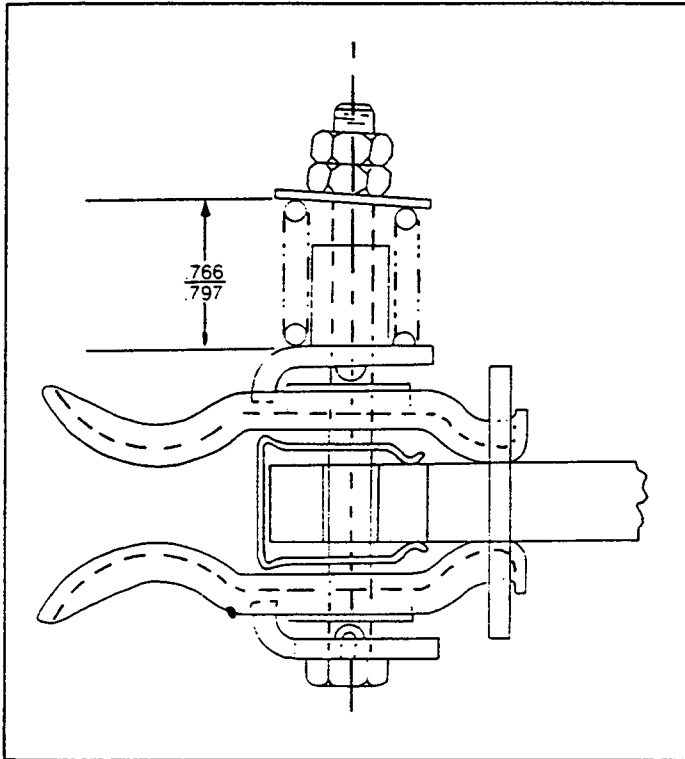

Fig. 48. Primary finger adjustment

7.2—Secondary Disconnects

The secondary disconnects for all drawout breakers serve as connections between breaker control circuit elements and external circuits. They are mounted on a horizontal cross-channel at the top rear of the breaker as shown in Fig. 49. These secondary disconnects allow removal of the breaker without having to detach external connections.

The moveable part of the secondary disconnects consists of an insulating body which holds a conducting spring-loaded plunger to which a flexible lead is attached, see Fig. 50. As the breaker moves into its enclosure, the plunger is depressed by sliding onto the stationary disconnects of the enclosure.

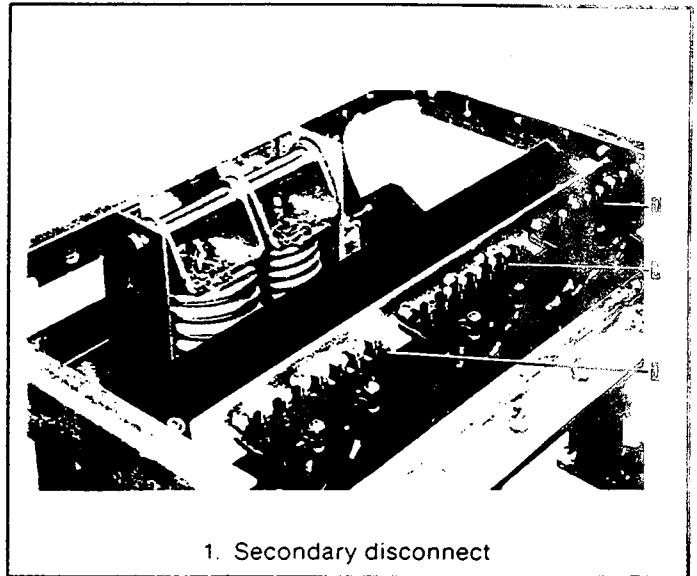

Fig. 49. Secondary disconnects

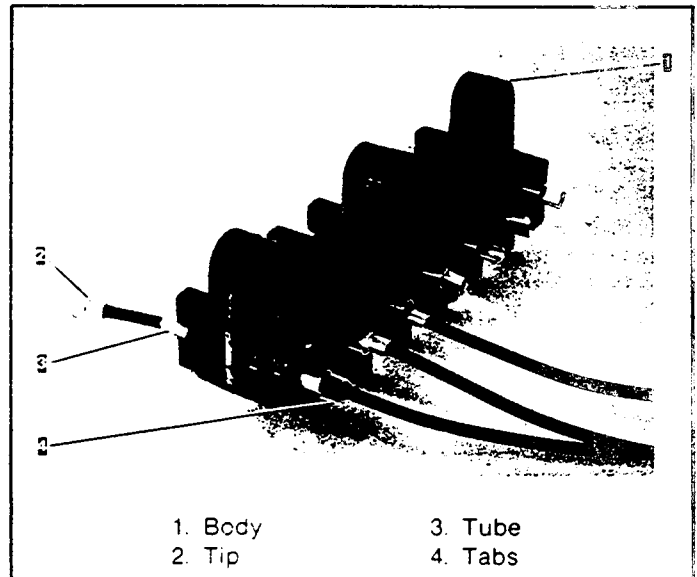

Fig. 50. Secondary disconnect details

7.2.1—Replacement

Replacement of the disconnects is given below. Refer to Fig. 50:

- a. Unfasten disconnect body from breaker cross-channel
- b. Open tabs which hold wires on inner side.
- c. Pull contact tip loose from hollow tube.
- d. Remove contact tip by cutting wire at its base.

(Continued next page)

SECTION 7—Accessories

7.2.1—(Cont.)

- e. Push wire through hollow tube of new disconnect assembly.
- f. Strip insulation off end of wire to about $\frac{1}{4}$ in. from the end.
- g. Place new contact tip on end of wire and crimp.
- h. Pull wire through hollow tube until contact tip fits snugly against end of hollow tube.
- i. Crimp tab on other side of assembly to hold wire in place.
- j. Any hollow tubes which are not used should be pushed into the disconnect body and held in that position by placing fiber spacers over inner ends of tubes and spreading tabs.
- k. When all wires have been connected, refasten the body of the moveable disconnect assembly to the breaker cross-channel.

7.3—Auxiliary Switch

All electrically operated breakers and manual breakers having shunt trips are supplied with auxiliary switches. Depending upon the requirements of the breaker application, the switch may contain two to six stages. Usually each stage one "A" contact and one "B" contact. "A" contacts are open or closed as the breaker is opened or closed. "B" contacts are the reverse of this.

The auxiliary switch is mounted on the upper left side of the mechanism frame as shown in Fig. 51. As the crossbar (1) moves to the open or closed position, it operates triangular link (2) via operating rod (3). The triangular link rotates the auxiliary switch operating shaft.

7.3.1—Replacement

Referring to Fig. 51:

GE SB-12

- a. Disconnect all leads.
- b. Remove two mounting bolts.
- c. Disengage auxiliary switch shaft (4) from triangular link (2).
- d. Orient the shaft of the new switch so that the arrow stamped on the shaft end points towards the front of the breaker.
- e. Push auxiliary switch shaft into square hole in link (breaker open).
- f. Replace mounting hardware and wiring.

Electro Switch

Follow the above procedure except in step d. In step d, orient the shaft of the new switch so that the horizontal line on the end of the shaft is horizontal when the breaker is open.

7.3.2—Adjustment

The auxiliary switch operating shaft must be positioned such that during breaker closing, the "a" contacts make before or not later than the first touch of the breaker's arcing contacts. If before, the open gap of the arcing contacts must not exceed $\frac{1}{4}$ -inch. This can be checked by connecting a bell set across the "a" terminals and slow-closing the breaker with the maintenance handle. The "a" contact closing can be advanced or retarded by lengthening or shortening operating rod (3), Fig. 51.

The operating rod should also be aligned vertically to be parallel with the sides of the frame center channel and perpendicular to crossbar (1). This is done by shifting the position of bracket (5).

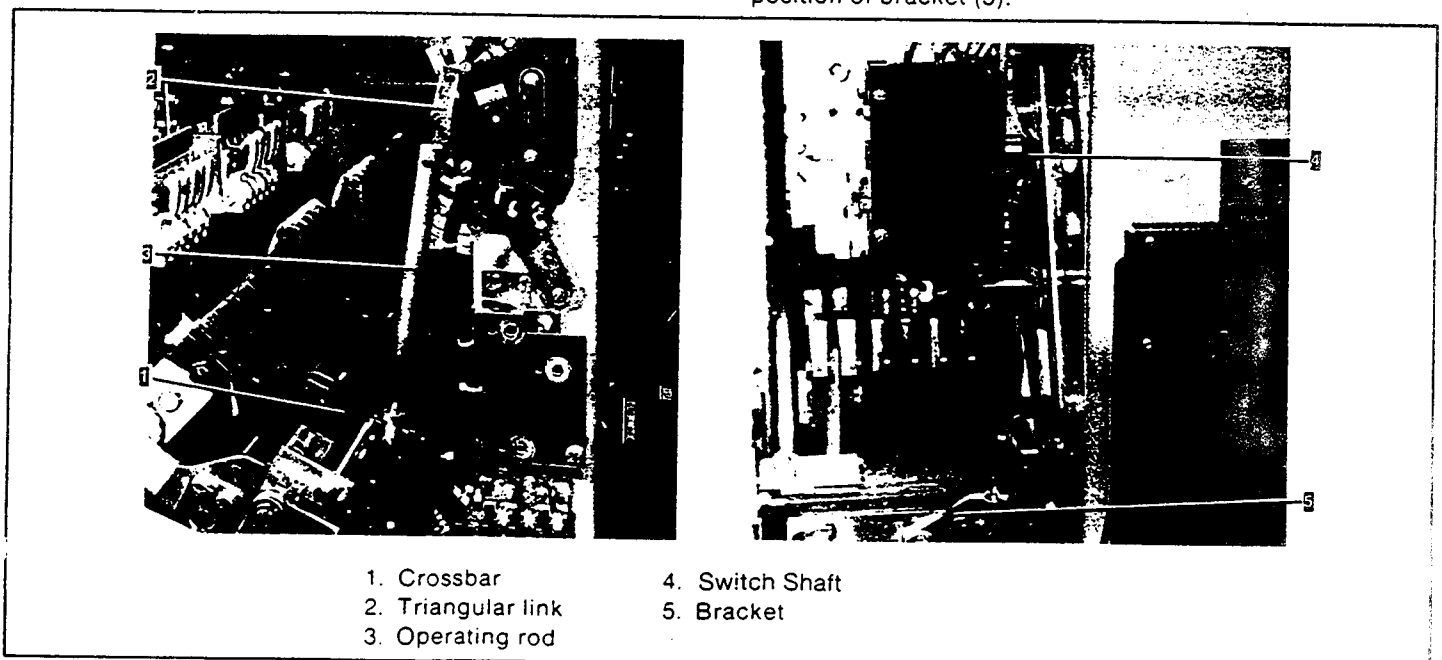

7.4—Shunt Trip

The shunt tripping device is mounted on a bracket attached to the left side of the operating mechanism (looking from the front).

A remote switch or relay contacts are used to close the circuit of the device causing the armature (9) to engage the trip paddle (11), thereby tripping the breaker. The spring (1) is used to return the armature to the neutral position after the breaker trips.

To prevent overheating, the coil (7) is cut off by contacts of the auxiliary switch which are open when the breaker is open.

7.4.1—Replacement

Referring to Fig. 52:

- a. Disconnect coil leads.
- b. Remove mounting hardware and the device.
- c. Install new device in reverse order.

7.4.2—Adjustments

With the shunt trip de-energized and the breaker mechanism reset, there must be clearance between trip paddle (11) and armature arm (10) 0.03 in. min.

A minimum 0.03 in. over-travel of the armature is required when the breaker is tripped. If any adjustment is necessary to provide this amount of overtravel, the trip lever is bent in or out accordingly.

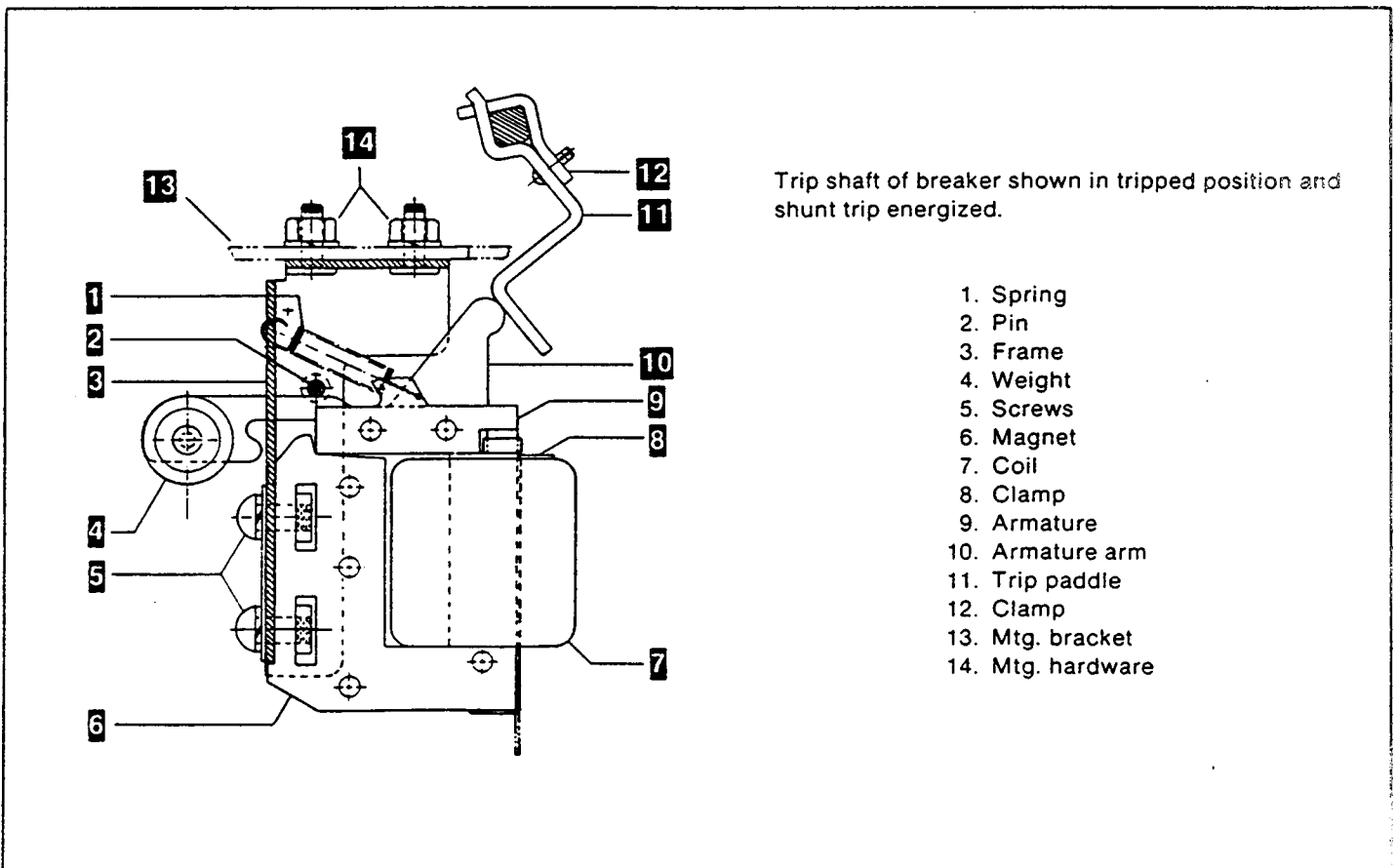

Fig. 52. Shunt trip device

SECTION 7—Accessories

7.5—Undervoltage Device

The undervoltage device (UV) is mounted on a bracket attached to the right side of the breaker operating mechanism (viewed from front). It trips the breaker when its coil is deenergized. The coil leads are connected directly to secondary disconnects or to a terminal board.

Under normal conditions, the coil remains energized, permitting the breaker to be closed. When the system voltage decreases to a value between 30 and 60 percent of its nominal value, the armature "drops out" and trips the breaker. An open armature prevents the breaker from being closed. The armature picks up and allows breaker closing, when the system voltage is 85 percent or more of its nominal value.

When the breaker is disconnected and is to be operated manually, the undervoltage device may be tied or wired down to prevent tripping.

7.5.1—Replacement

Referring to Fig. 53:

- a. Disconnect coil leads.
- b. Remove mounting screws and remove device.
- c. Install new device in reverse order.

7.5.2—Adjustment

When this device is installed or replaced, its positive ability to trip the breaker must be demonstrated.

Undervoltage devices trip the breaker when the armature opens. This causes an extension of the armature to strike the paddle on the trip shaft. An extension on the other end of the armature (towards the front of the breaker) extends through the device frame and limits the movement of the armature. When the armature is released, this extension stops against a stop which is factory set. To check positive trip, the armature should be held down, the end of a 1/32-inch diameter wire should be inserted against the stop, and the armature released. If this trips the breaker, the setting is correct. The place to insert the wire is shown in Fig. 54. Note that only the tip of the wire is to be against the stop.

If the undervoltage device does not have positive tripping ability, the adjustment screw of the trip paddle assembly on the trip shaft may be turned in increments of half turns until the check is successful.

When the undervoltage device is closed and the breaker mechanism is reset, there must be clearance between the trip paddle and the device armature.

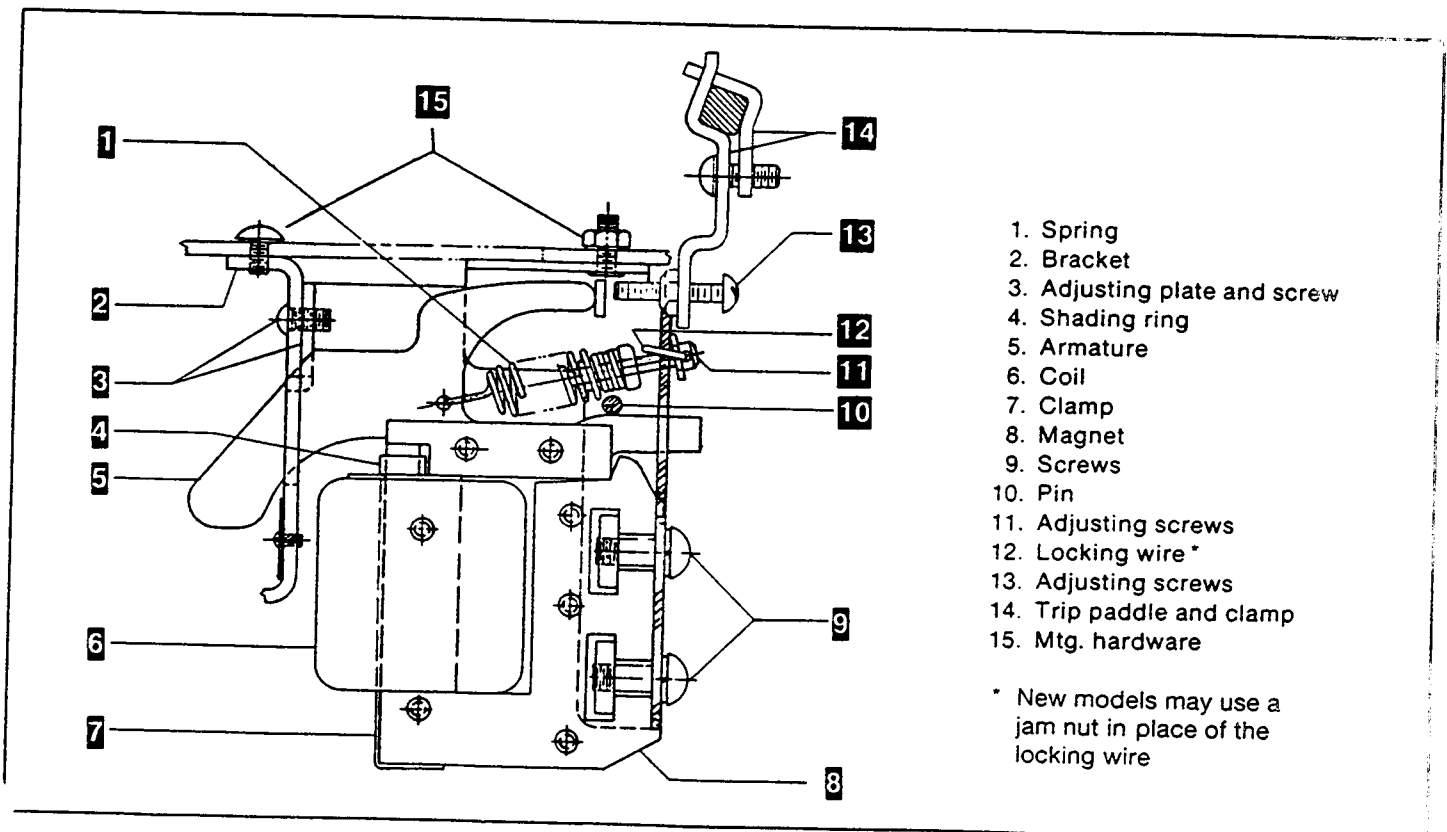

Fig. 53. Undervoltage device - energized (breaker reset)

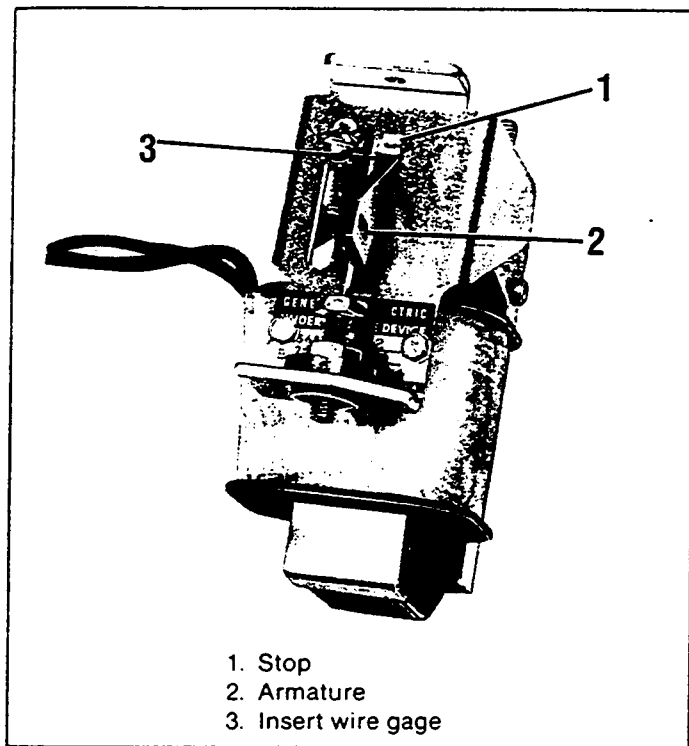

Fig. 54. Positive trip check

7.6—Static Time-Delay Undervoltage

In addition to the instantaneous undervoltage tripping device mounted on the breaker, the static time-delay undervoltage includes a separately mounted time-delay unit. Table 7 lists the Cat. Nos. available.

If the a-c control voltage is any voltage other than 208/240V ac, a control power transformer (also remotely mounted with respect to the breaker) must be used. This must have a minimum rating of 100 volt-amperes.

When installed, the voltage to be monitored is connected across terminals No. 1 and No. 2 of the static delay box. The coil of the tripping unit is connected across terminals No. 4 and No. 5 of the static box through the secondary disconnects of the breaker. The secondary disconnects to be used will be shown on the breaker wiring diagram.

No more than one undervoltage tripping device should be used in conjunction with one static time-delay unit.

The static time-delay undervoltage can also be furnished with a thermotector control unit. Overheating of motor windings causes the thermotector, imbedded in the motor windings, to open. This de-energizes the undervoltage device on the breaker and drops the motor load.

In the event the device fails to pick-up, the following checks are recommended to determine whether the magnetic device on the breaker of the static time delay unit is the faulty component:

1. Check input voltages across terminals 1 and 2 on the static box. See Table 7 for these values.
2. Check output voltages on terminals 4 and 5 with the undervoltage device connected. See Table 7 for values.
3. Check resistance of the disconnected undervoltage device. See Table 7 for values.

See Instruction Sheet GEH-4545 for more detailed information, including schematic diagrams and circuit description.

Table 7—Time-Delay Units

CAT. NO.	CONTROL VOLTAGE TERMINALS 1 & 2	APPROXIMATE STEADY STATE DC OPERATING VOLTAGE TERMINALS 4 & 5	NOMINAL DC COIL RESISTANCE (OHMS) @ 25°C
TAKYUVT-1	125 VDC	50	440
TAKYUVT-2	250VDC	100	1600
TAKYUVT-3	208 240 VAC	110 125	1600

SECTION 7—Accessories

7.7—Electric Lockout Device

The Electric Lockout Device is used in conjunction with the normally-closed auxiliary contacts of another breaker. This device provides a convenient method to electrically interlock two or more breakers so that no two may be closed at the same time. When its coil is de-energized, the electric lockout device holds an open breaker trip-free. However, once the breaker is closed, the breaker mechanism cam operates linkage which mechanically holds the lockout device armature closed to prevent tripping the breaker in the event the lockout coil is de-energized.

The lockout device is mounted on the right side of the mechanism frame viewed from the front as shown in Fig. 55. When the breaker opens, the breaker cam moves down, allowing the lockout device to assume its normal, de-energized position.

Each electric lockout device also includes a By-Pass or "manual defeat" linkage to permit closing the breaker when the lockout is de-energized. This allows startup of "dead" systems. A pull knob for this purpose is located beneath the breaker frame.

7.7.1—Adjustment

All lockout devices are factory adjusted. If adjustments are needed, referring to Fig. 55:

a. Adjust "manual defeat" linkage adjusting nuts to obtain max travel of lockout tripping arm.

b. With breaker in open and reset position and lockout coil de-energized, pull knob for "manual defeat". Check clearances between lockout trip arm and adjusting screw. Clearance must be .06 to .09. Release knob, lockout trip arm must move trip paddle .03 to .06 beyond point of tripping breaker. Adjust screw accordingly.

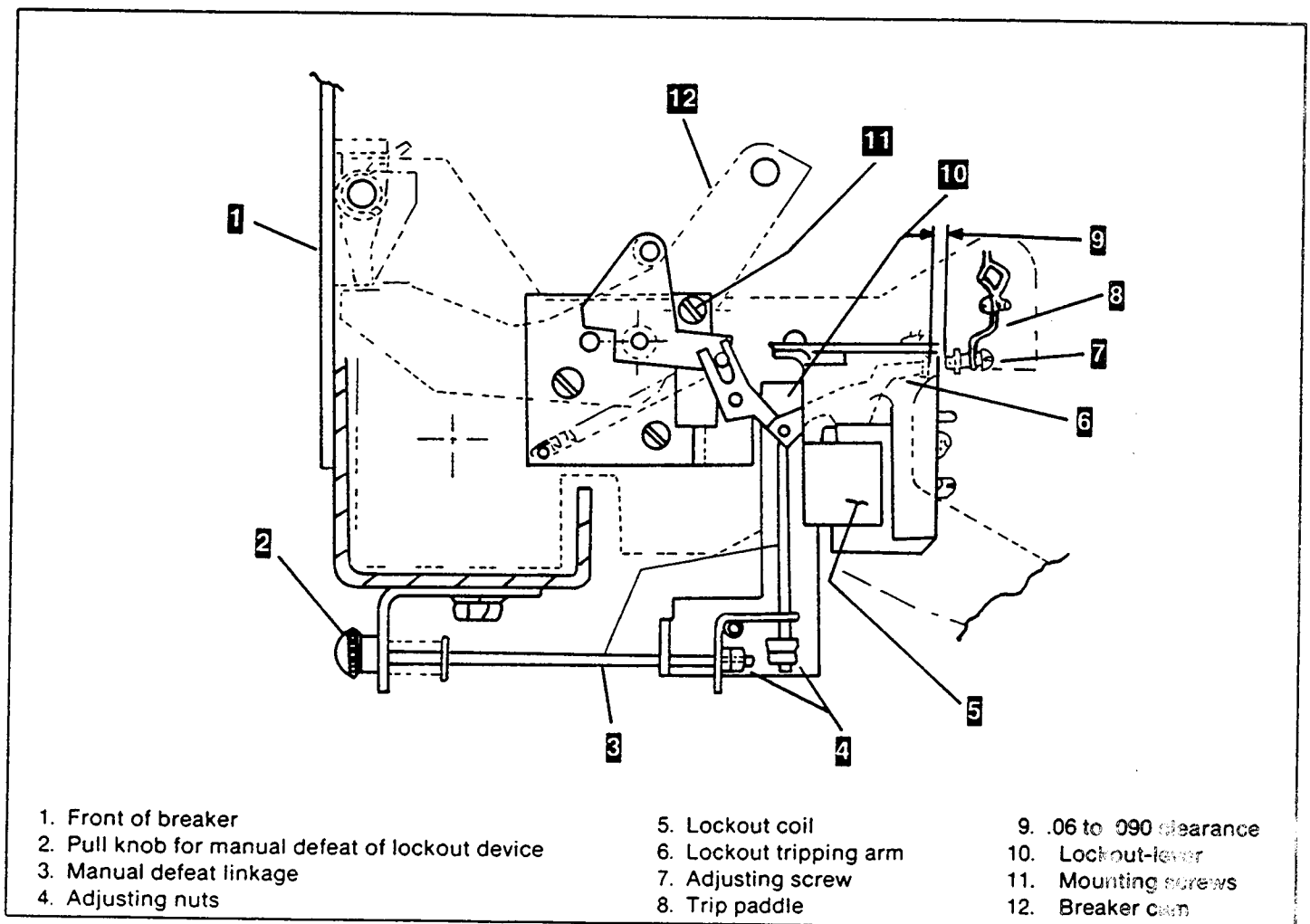

Fig. 55. Electric lockout device (breaker closed)

7.8—Bell Alarm Device

This device provides a means for remote indication that the breaker has been tripped due to action of one of its automatic trip devices (overcurrent, UV) or drawout interlocks. It is not activated by the manual trip button or shunt trip device.

The bell alarm device can be equipped with an optional lockout feature which, upon activation of the bell alarm, prevents reclosure of the breaker until the bell alarm is reset. A bell alarm without the lockout feature can be turned off (reset) by any of three modes:

- a. Reclosing the breaker.
- b. Depressing the manual trip button.
- c. Energizing the shunt trip device. For this mode, a normally open contact of the bell alarm switch must be connected in parallel with the auxiliary switch "A" contact in the shunt trip circuit.

For a bell alarm with lockout, only reset modes (b) and (c) apply.

7.8.1—Adjustment

In Fig. 56, the components of a bell alarm with lockout are shown in the breaker closed position. The device is actuated by crossbar side link pin (1) which engages operating link (2). Lockout screw (3) should be adjusted so that it engages trip paddle (4) to displace trip shaft (6) when the breaker is opened. This keeps the breaker trip free until the bell alarm is reset.

Operating the manual trip button must not actuate the bell alarm device. With the manual trip button fully depressed, the trip rod release collar (7) should be positioned on trip rod (8) so that latch (9) and catch (10) disengage before the breaker opens. When the manual trip button is not depressed, there should be approximately a $\frac{3}{16}$ " gap between the trip rod release collar (7) and the latch (9).

The bell alarm is bypassed also whenever the shunt trip is energized. This is accomplished by latch release strap (11) which is engaged by shunt trip armature lever (12). Strap (11) is part of device latch (9), and must be formed to hook around armature lever (12) such that the device latch and catch disengage before the breaker opens.

With the breaker in reset position there must be at least $\frac{1}{16}$ clearance between shunt trip armature (12) and breaker trip paddle (4).

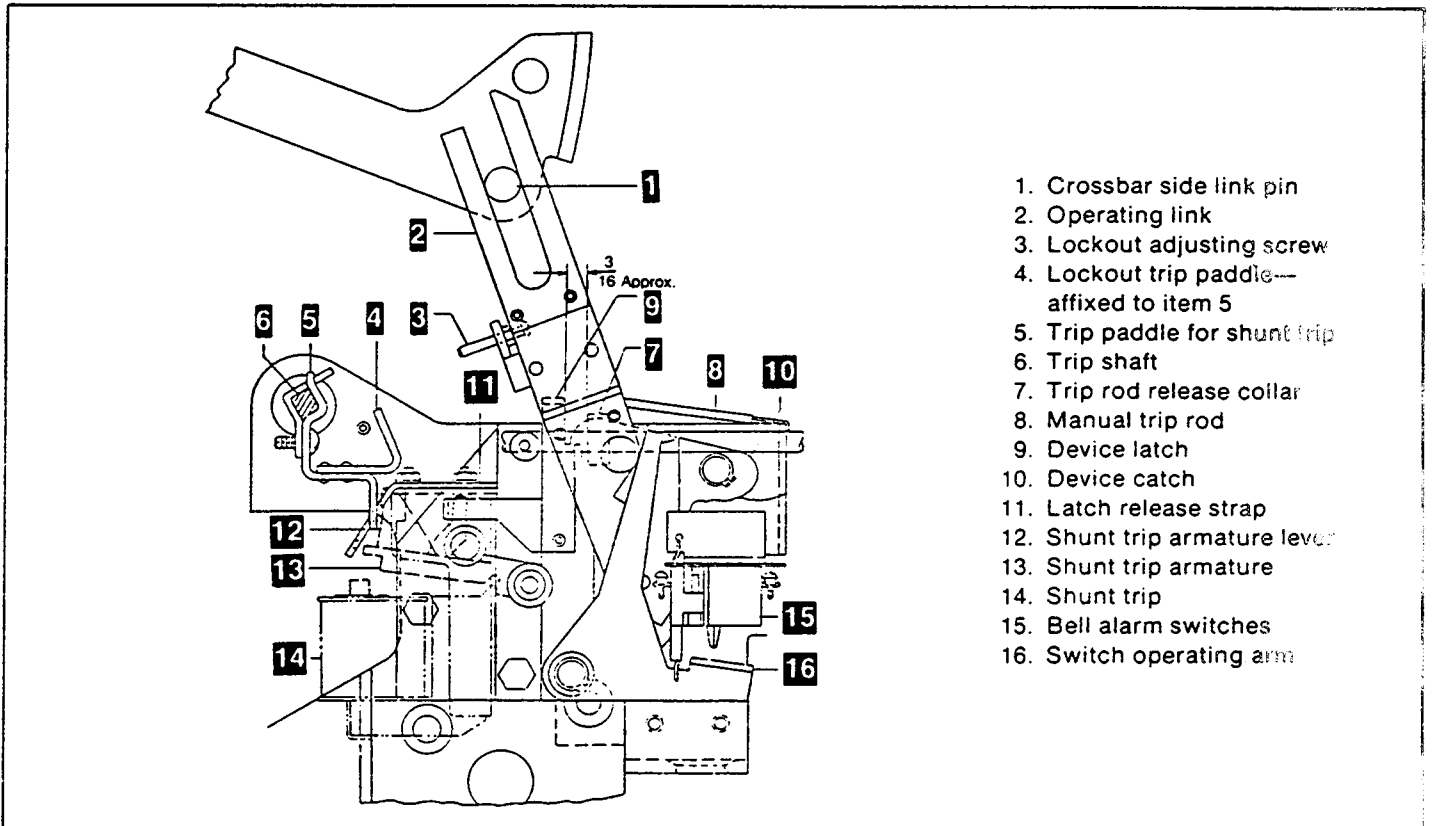

Fig. 56. Bell alarm device

SECTION 7—Accessories

7.9—Open Fuse Lockout Device

The open fuse lockout device (OFLO) is an anti-single-phasing device used on breakers employed in conjunction with current-limiting fuses. The device consists of an individual trip solenoid for each pole, connected directly across the fuse in that phase. Blowing of any fuse operates its solenoid, tripping the breaker. An indicator for each phase pinpoints the blown fuse. The breaker remains trip-free until the involved phase of the OFLO device is reset.

Referring to Fig. 57, when a fuse blows, coil (6) in that phase is energized and closes armature (8), engaging trip paddle (1) which trips the breaker. In the process, spring (12) discharges and pivots arm (9) counterclockwise, latching armature (8) closed. This motion also moves reset button (10) forward, indicating which fuse has blown. The latch-held armature keeps the breaker trip-free until the OFLO is reset. Coil (6) is de-energized as soon as the breaker is tripped.

7.9.1—Coil Replacement

To replace coil (6), proceed as follows:

1. Remove five bolts mounting the device to the side plate and front frame. Lower the lockout device, guiding

rod (3) through rod guide (2). Continue lowering the device until movement is restricted by the device wiring harness.

2. Disconnect coil leads.

3. Remove two screws holding the trip device to the device mounting plate.

4. Bend lower end of brass coil clamp straight.

5. Remove coil. Install new coil and replace parts in reverse order.

7.9.2—Adjustments

From 1/32 to 1/16 inch armature overtravel is required when the breaker is tripped. A 1/8-inch minimum clearance is needed between trip paddle (1) and rod (3) with breaker in the reset position. To make these adjustments loosen locknut (4) and turn rod (3) in or out to obtain the proper overtravel and clearance. Retighten lock nut (4).

A 1/8-inch minimum clearance should be maintained at reset button (10). To adjust, loosen lock nut ahead of button and turn button until proper distance is obtained. Retighten lock nut.

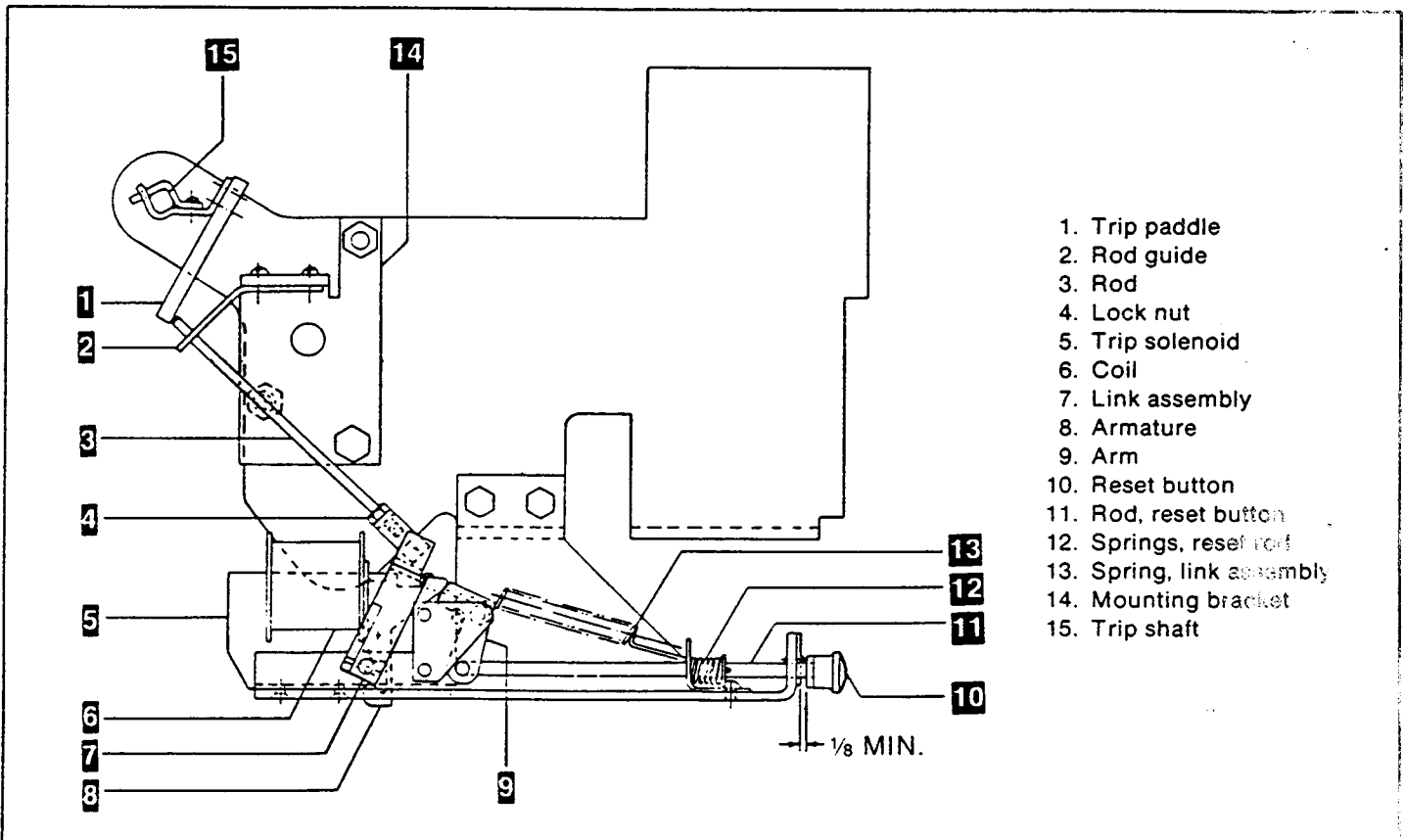

Fig. 57. Open fuse lockout device

SECTION 8—Type SST Overcurrent Trip Device

The SST is a solid-state, direct-acting, self-powered trip device system. The SST system consists of the SST programmer unit, current sensors, and a flux shifter trip device. Fig. 58 shows a block diagram of the system.

8.1—Programmer Unit

Fig. 59 shows a typical SST programmer unit. The programmer unit provides the comparison basis for overcurrent detection and delivers the energy necessary to trip the breaker. It contains the electronic circuitry for the various trip elements. Their associated pickup and time delay adjustments (set-points) are located on the face plate. Depending on the application, programmer units may be equipped with various combinations of Long Time, Short Time, Instantaneous and Ground Fault trip elements. See Table 8 for available ratings, settings and trip characteristics. Adjustments are made by removing the clear cover over the face plate, unscrewing (counter-clockwise) the set-point knob, moving the set-point along the slot to the new setting, and screwing the set-point knob in. Once all adjustments are made, install the clear cover to the face plate.

The SST programmer units can be optionally equipped with trip indicators (targets). These are pop-out, mechanically-resettable plungers located across the top of the programmer's front. Units with a ground fault element employ three targets: from left to right, the first is for overload, the second for short circuit (actuated by the short time and instantaneous elements) and the third for ground fault. The latter is omitted on units without ground fault.

Each target pops out when its associated trip element operates to trip the breaker. After a trip, the popped target must be reset by hand. However, neglecting to reset does not affect normal operation of any trip element or prevent the breaker from being reclosed.

The programmer unit is mounted to the left side of the breaker as shown in Fig. 60. The bracket attached to the top of the programmer, see Fig. 59, engages with a bracket mounted to the breaker's center channel.

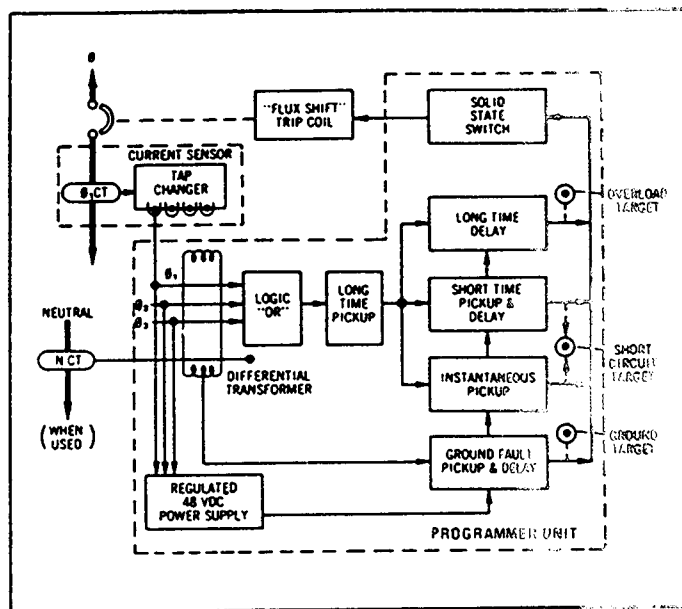

Fig. 58. SST block diagram

Table 8—SST Trip Characteristics

Breaker Frame Type	Frame Size (Amperes)	Sensor Taps (X) (Amperes)	SST PROGRAMMER ADJUSTMENT RANGE (Set Point)						Instantaneous Pickup (Multiple of L)
			Ground Fault		Long Time		Short Time		
			Pickup (Multiple of X)	Delay Band (Seconds)	Pickup (L) (Multiple of X)	Delay Band (Seconds)	Pickup (Multiple of L)	Delay Band (Seconds)	
AKS-5/5A-50	1600	300, 400, 600, 800 or 600, 800, 1200, 1600	.25, .3, .4, .5, .6 (X)						
AKST-5/5A-50	2000	800, 1200, 1600, 2000	.2, .25, .3, .4, .5, .6 (X)						
AK-5/5A-75 AKR-5/5A-75	3000	1200, 1600, 2000, 3000	.2, .22, .25 .3, .35, .37 (X)	Maximum 0.30		Maximum 22	1.75, 2, 2.25, 2.5, 3, 4 (L)	Maximum 0.35	
AKR-5B/5C/5S-75	3200	1200, 1600, 2000, 3200		Intermed. 0.165	6, 7, 8, 9, 1, 1.1 (X)	Intermed. 10	—or— 3, 4, 5, 6 8, 10 (L)	Intermed. 0.21	4, 5, 6, 8, 10, 12 (L)
AK-100 AKR-100	4000	1600, 2000, 3000, 4000	.18, .2, .22, .25, .27, .3 (X)	Minimum 0.65		Minimum 4	3, 4, 5, 6 8, 10 (L)	Minimum 0.095	
NOTES			1	2	3	4	5	6	7

¹ X = Sensor ampere rating = trip rating

² Pickup tolerance = ± 10%

³ Time delay at lower limit of band @ 6L.

⁴ Time delay at lower limit of band.

Applicable time-current curves: GES-6033B, 6034A, 6035B

SECTION 8—Type SST Overcurrent Trip Device

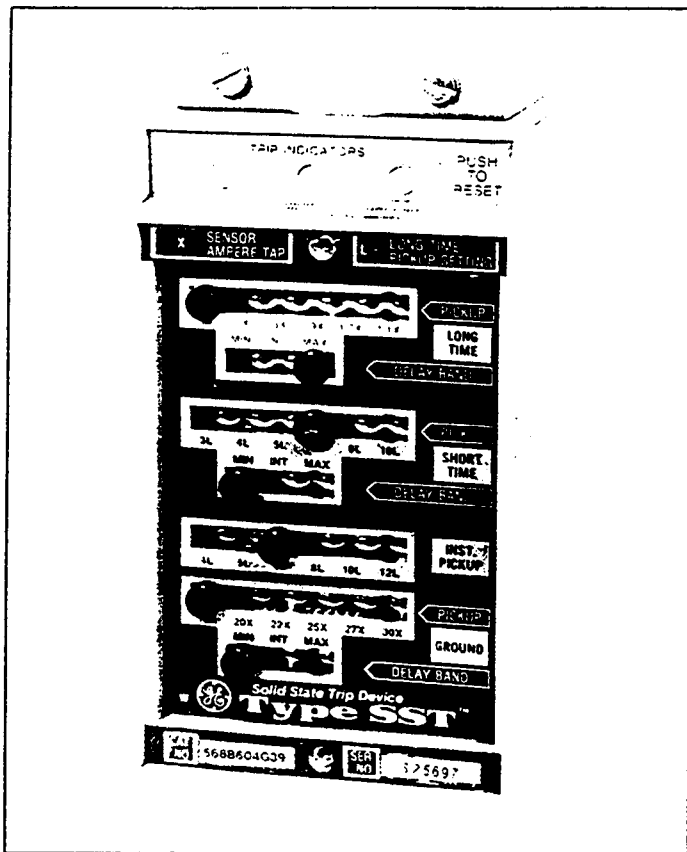

Fig. 59 SST programmer

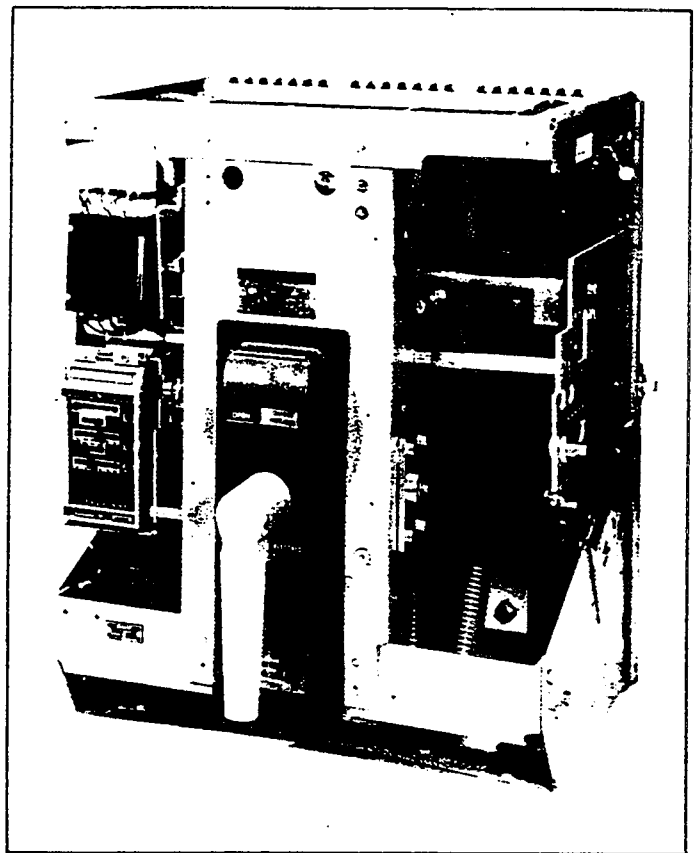

Fig. 60. AKS-5A-50

8.2—Current Sensors

The SST system uses two types of current sensors, a phase sensor and a neutral sensor. Fig. 61 shows a phase sensor. Fig. 62 shows the neutral sensors available. The current sensor supplies the power and signal inputs necessary to operate the trip system. Each sensor has four taps which provide field adjustment of the trip device's continuous ampere rating.

The SST Ground Fault trip element operates on the principle that the instantaneous values of current in the three conductors (four on 4-wire systems) add to zero unless ground current exists. On SST's equipped with Ground Fault, the ground trip signal is developed by connecting each phase sensor in series with a companion primary winding on a ground differential transformer mounted in the programmer unit. Its secondary output is zero so long as there is not ground current.

Application of the Ground Fault element on 4-wire systems with neutral grounded at the transformer requires the additional, separately mounted neutral sensor (Fig. 62) inserted in the neutral conductor; its secondary is connected to a fourth primary winding on the ground differential transformer. See Fig. 72. This "fourth-wire" neutral sensor is an electrical duplicate of the phase sensor, including taps. Therefore, when taps are changed on the phase sensors, those on the neutral sensor must be correspondingly positioned.

When used, the neutral sensor is separately mounted in the bus or cable compartment of the switchgear. In drawout construction, its output is automatically connected to the breaker via secondary disconnect blocks. See Fig. 63.

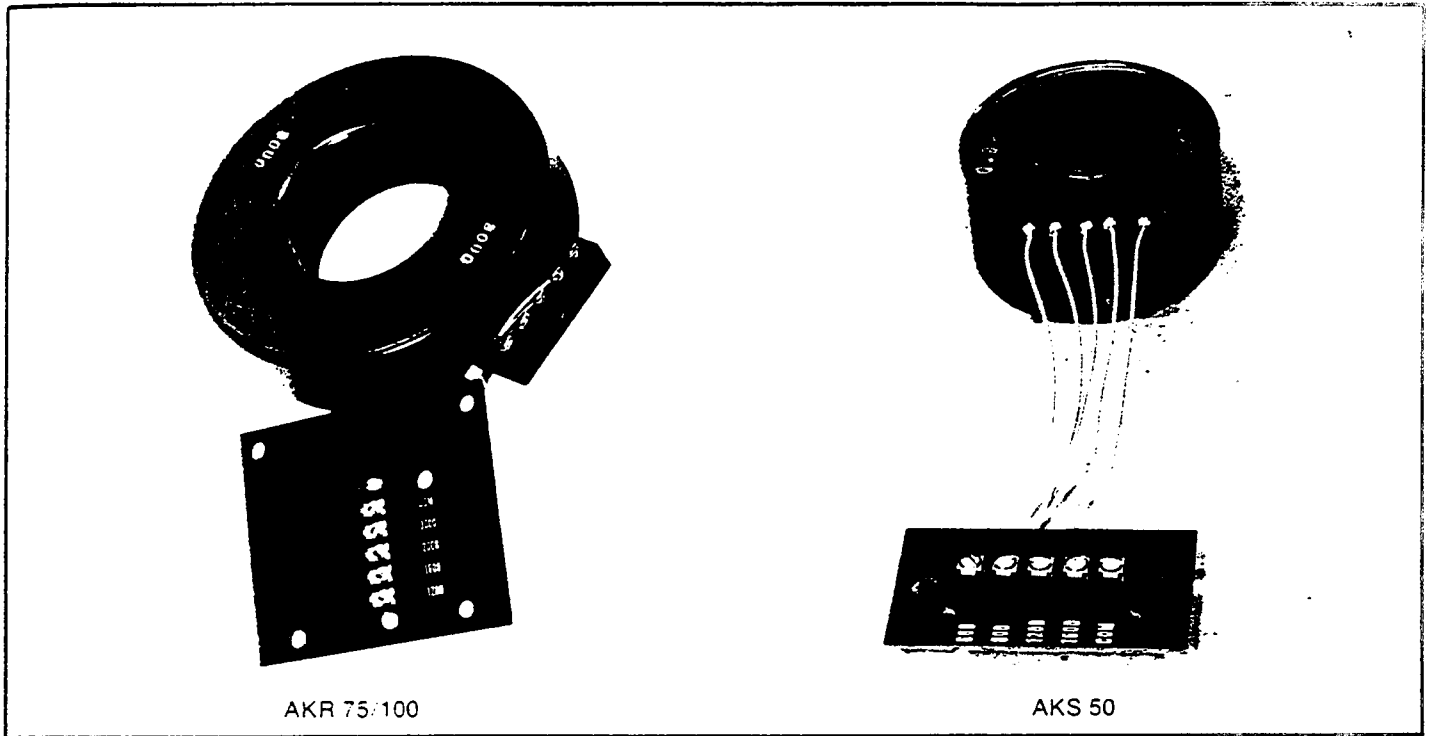

Fig. 61. SST phase sensors with tap board

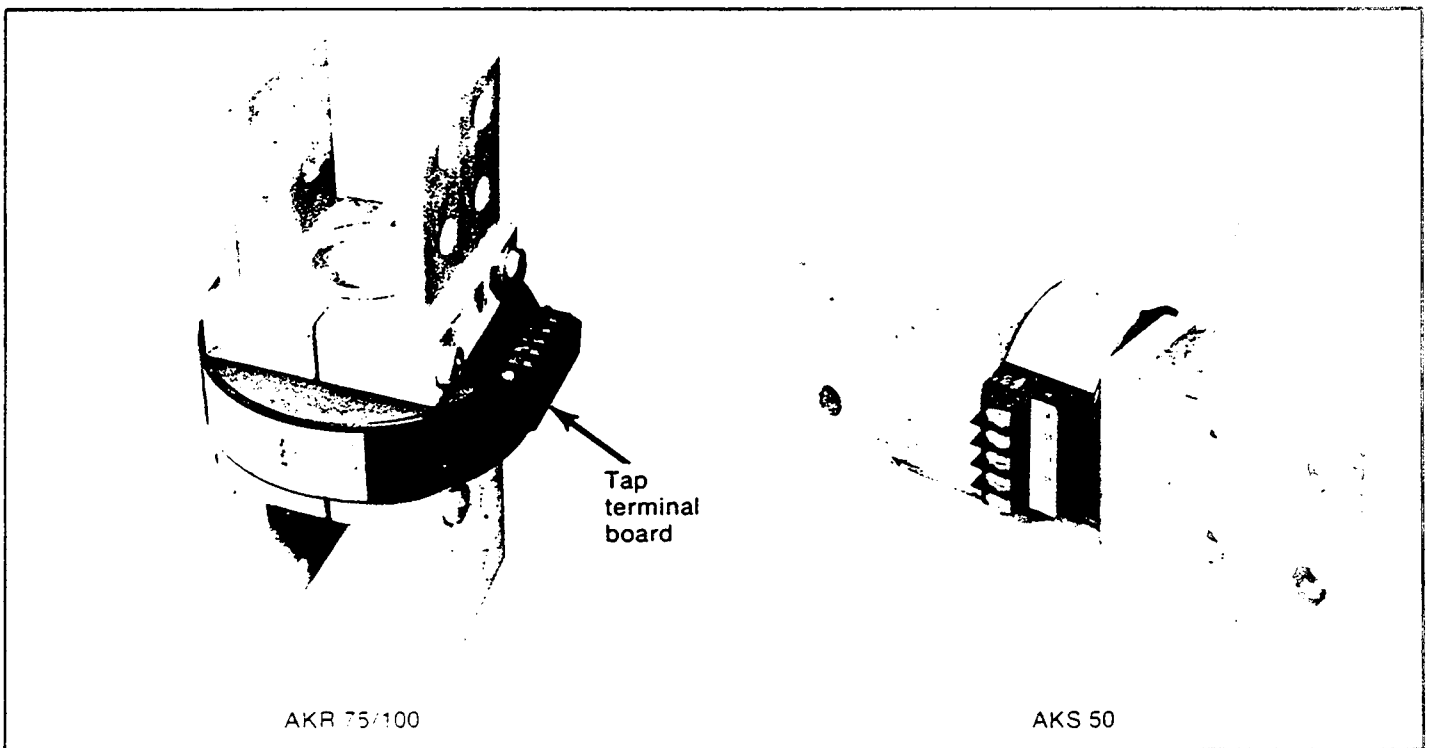

Fig. 62. SST neutral sensors

SECTION 8—Type SST Overcurrent Trip Device

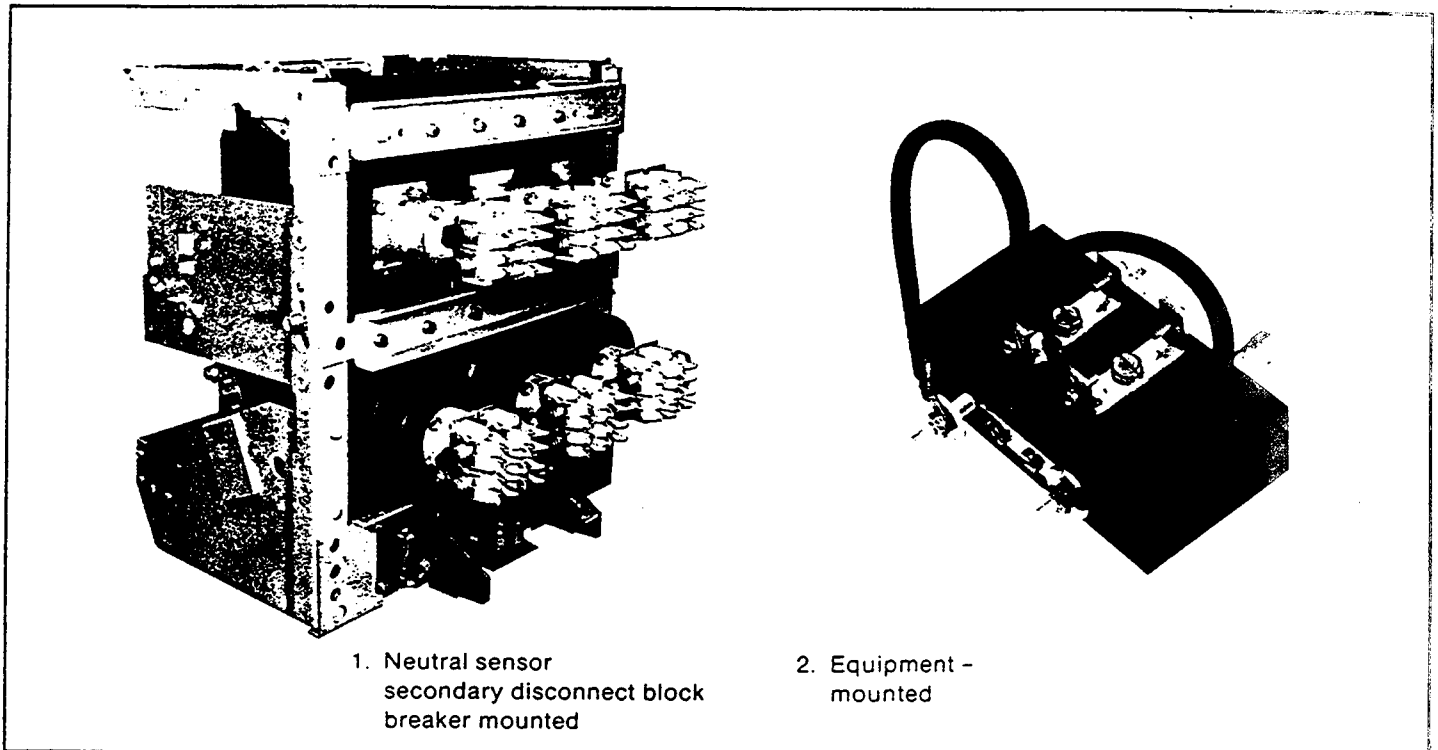

Fig. 63. Neutral sensor secondary disconnect block

8.2.1—Replacement of Current Sensors - AKS 50

Referring to Fig. 64, AKS50 phase sensors are removed as follows:

- a. Remove the connections to and the wiring harness from the sensor tap board.
- b. Remove the tap board retaining hardware.
- c. Remove the lower connection strap.
- d. Sensors are secured with RTV. Loosen RTV and remove sensors.
- e. If the front and back frame have not been separated, replacement of the center pole sensor requires removal of the mechanism prop. Refer also to Fig. 24:
 1. Remove retaining rings.
 2. Disconnect spring.
 3. Remove bearings
 4. Remove prop.

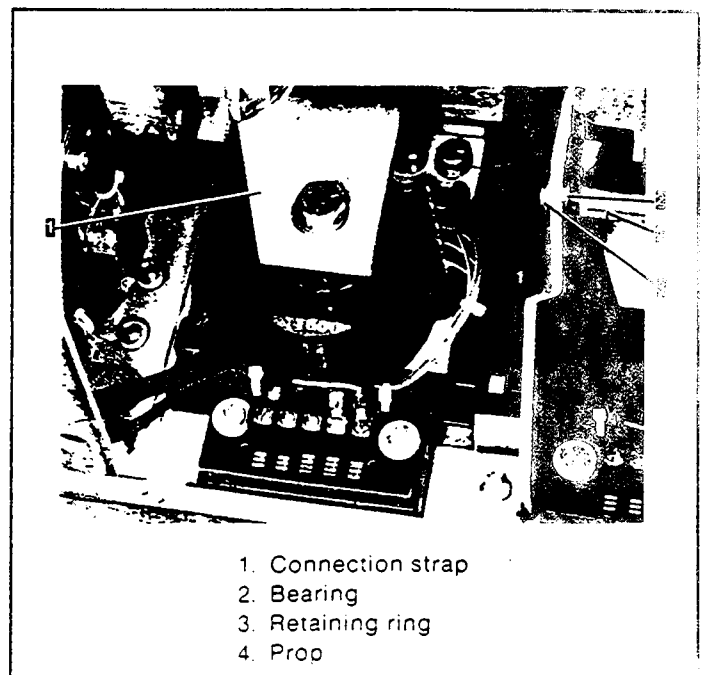
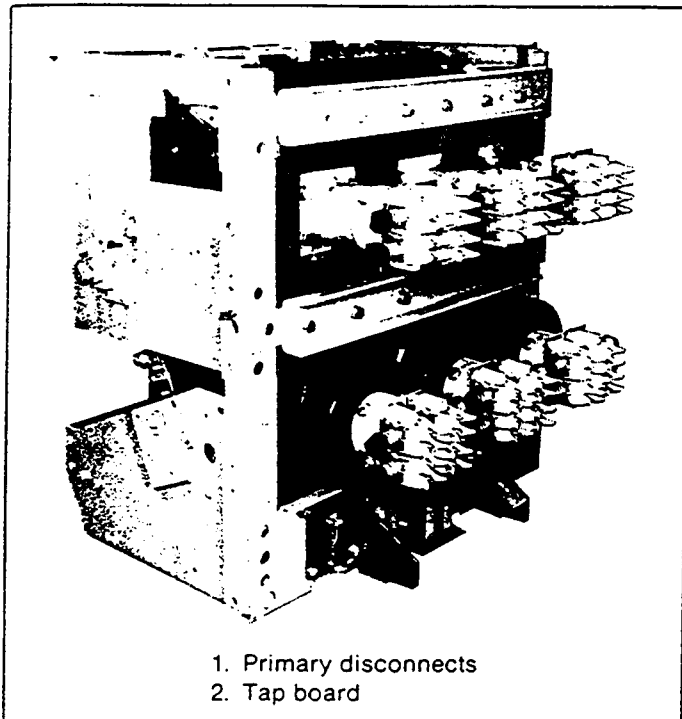

Fig. 64. Sensor replacement



1. Primary disconnects
2. Tap board

Fig. 65. AKR 75/100 sensor replacement

8.2.2—Replacement of Current Sensors - AKR 75/100

Referring to Fig. 65, the AKR 75/100 phase sensors are removed as follows:

- a. Disconnect the wiring harness and connections from the sensor tap board.
- b. Remove the tap board hardware.
- c. Remove the primary disconnect assemblies from the stud.
- d. Remove the sensor and tap board.
- e. Reassemble in reverse order, align projections on rear of sensor with notches in the position ring which is mounted on the stud. Refer to Section 7.1.1 for torque requirements for the primary disconnect hardware.

8.3—Flux Shift Trip Device

The Flux Shift Trip device is a low-energy, electromagnetic device which, upon receipt of a trip signal from the programmer unit, trips the breaker by actuating the trip shaft.

The mounting arrangement of this component is illustrated in Figs. 66 and 67. An electromagnetic actuator located on

the underside of the front frame is coupled to the breaker's trip shaft via a trip rod driven by the actuator arm. The actuator is a solenoid whose armature is spring-loaded and held in its normal (Reset) position by a permanent magnet. In this state the spring is compressed.

So long as the actuator remains in the Reset position, the breaker can be closed and opened normally at will. However, when a closed breaker receives a trip signal from the programmer unit, the actuator is energized and its solenoid flux opposes the magnet, allowing the spring to release the armature; this drives the trip rod against the trip shaft paddle, tripping the breaker.

As the breaker opens, the actuator arm is returned to its normal (Reset) position via linkage driven by a crank on the breaker's main shaft. The permanent magnet again holds the armature captive in readiness for the next trip signal.

The trip device requires only one adjustment—the trip rod length. As shown in Fig. 68, the clearance between the trip rod end and the trip shaft paddle is gaged by a 0.109 inch diameter rod. Adjust gap to 0.109 inch \pm 0.031 inch. To adjust, open the breaker and restore the breaker mechanism to its Reset position. Loosen the jamb nut, rotate the adjuster end until the proper gap is attained, then retighten the jamb nut.

While operating the breaker, insure that the actuator bracket does not interfere with the buffer stud. Adjust by loosening actuator bracket mounting screws and rotating the bracket clockwise to take up mounting hole slack. Retighten screws.

The actuator is a sealed, factory-set device and requires no maintenance or field adjustment. In case of malfunction, the complete actuator unit should be replaced. When making the electrical connection to the replacement unit, it is recommended that the breaker harness be cut at some convenient point and the new actuator leads solder-spliced thereto. An alternate method is to untie the breaker harness and remove the old actuator leads directly from the female AMP connector on the end of the breaker harness. However, AMP extraction tool Cat. No. 305183 is required for this method.

CAUTION: IF THE BREAKER MUST CARRY CURRENT WITHOUT OVERCURRENT PROTECTION, THE SST TRIP DEVICE SYSTEM MUST BE PREVENTED FROM OPERATING. THE RECOMMENDED METHOD IS TO SHORTEN THE TRIP ROD BY TURNING ITS ADJUSTER END FULLY CLOCKWISE. THIS PREVENTS ACTUATION OF THE TRIP SHAFT PADDLE.

SECTION 8—Type SST Overcurrent Trip Device

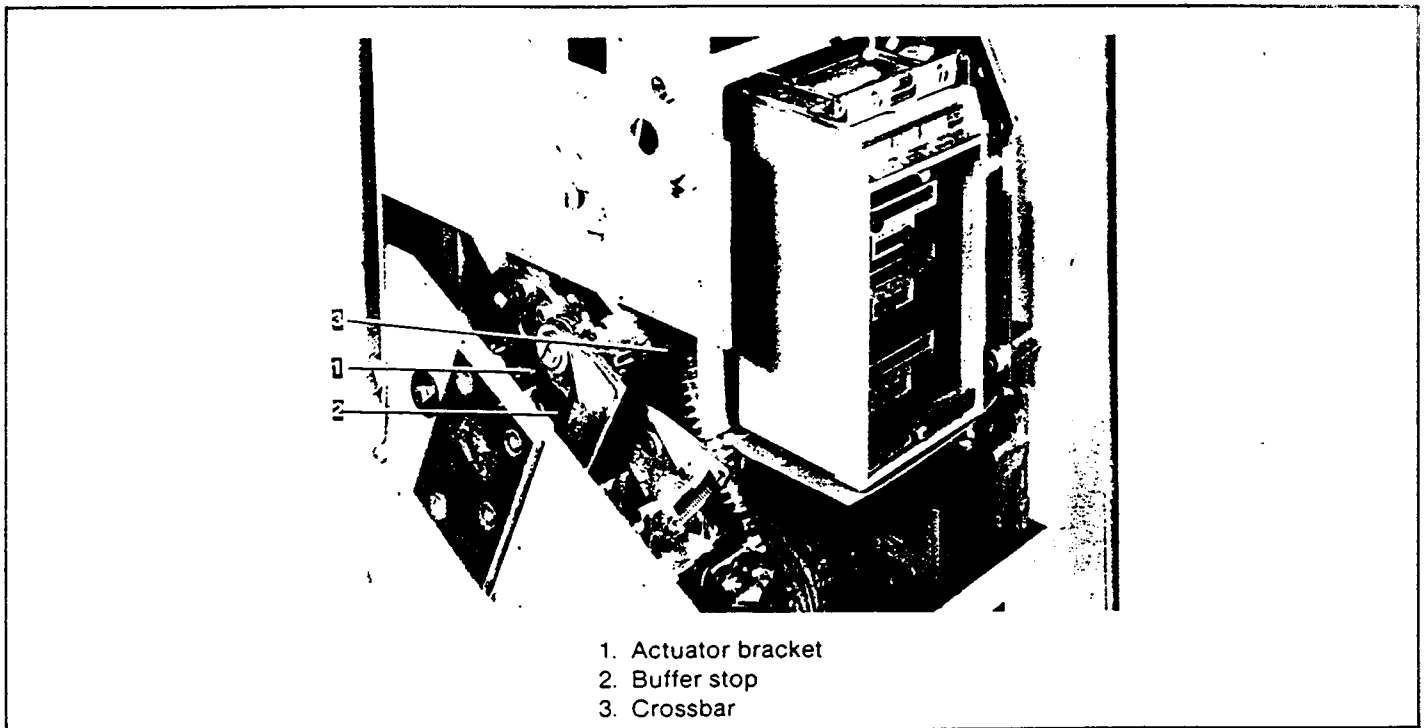

Fig. 66. Flux shift trip device - linkage attachment

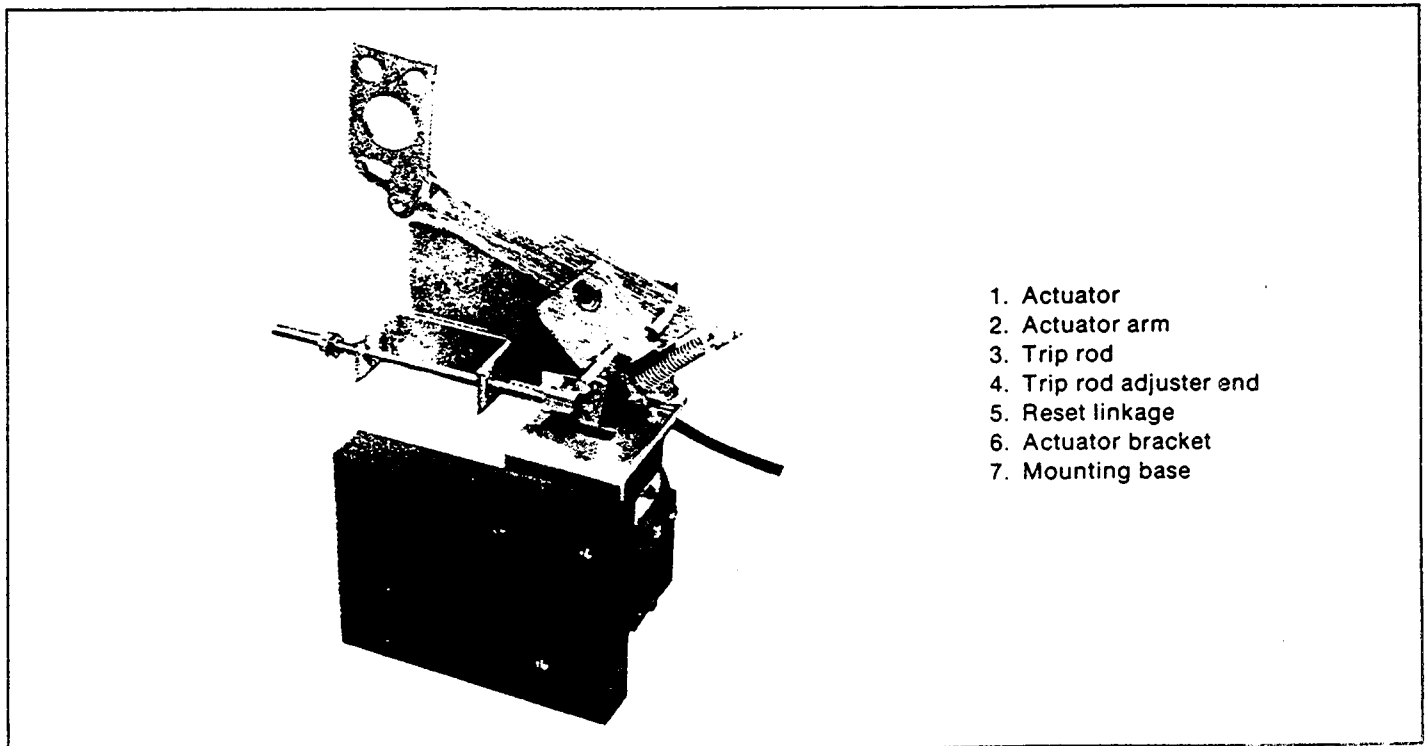
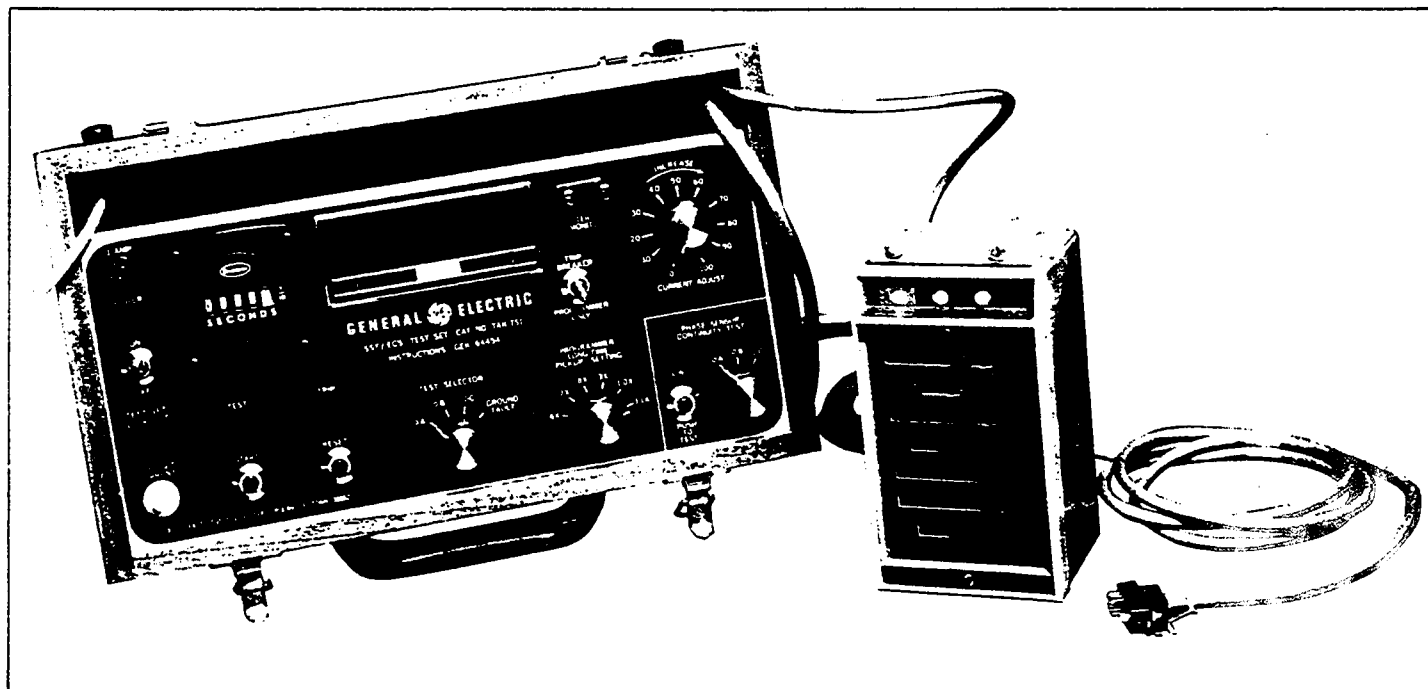
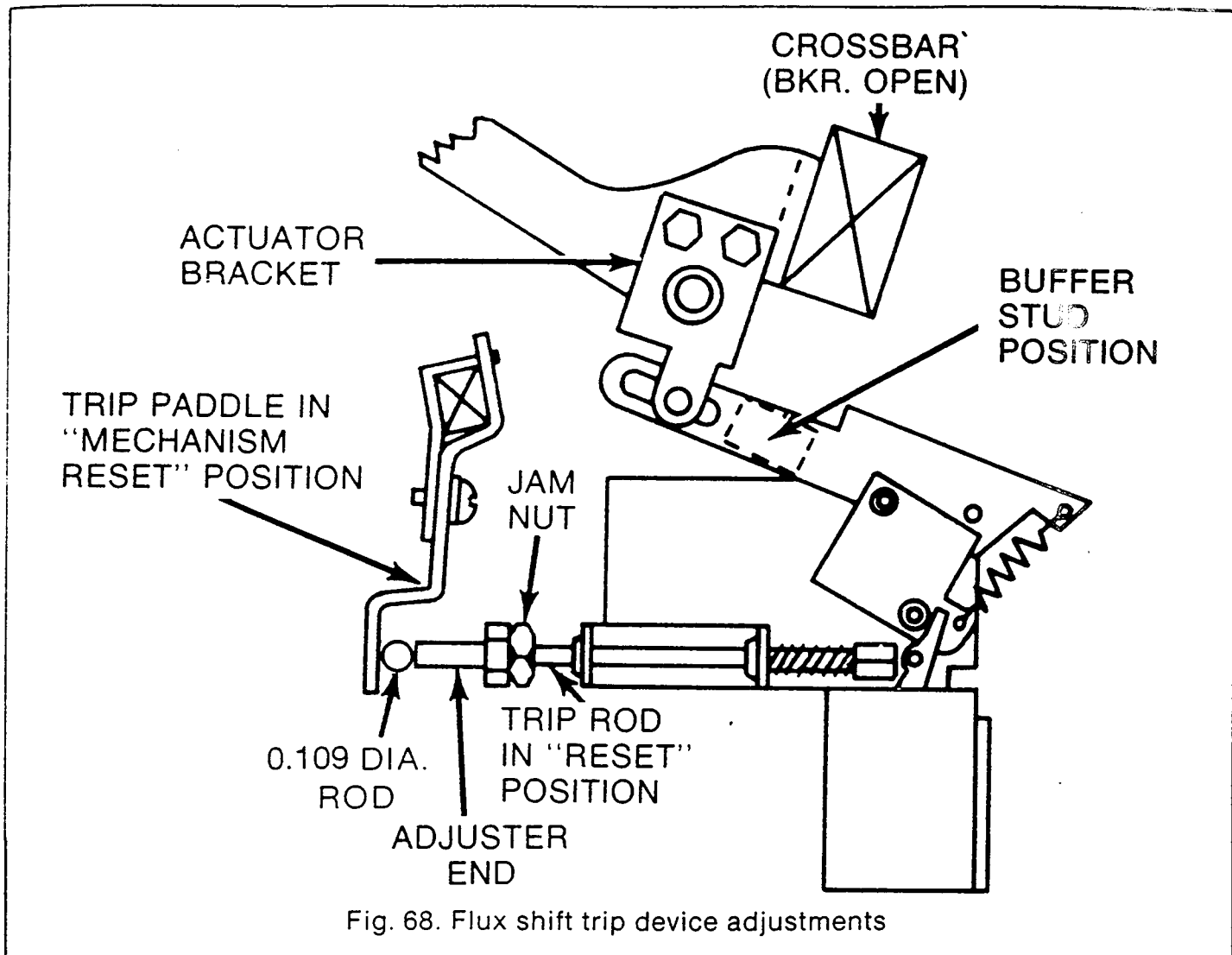

Fig. 67. Flux shift trip device with operating linkages



SECTION 8—Type SST Overcurrent Trip Device

8.4—Troubleshooting

When malfunctioning is suspected, the first step in troubleshooting is to examine the circuit breaker and its power system for abnormal conditions such as:

- a. Breaker tripping in proper response to overcurrents or incipient ground faults.
- b. Breaker remaining in a trip-free state due to mechanical interference along its trip shaft.
- c. Inadvertent shut trip activations.

WARNING: DO NOT CHANGE TAPS ON THE CURRENT SENSORS OR ADJUST THE PROGRAMMER UNIT SET KNOBS WHILE THE BREAKER IS CARRYING CURRENT.

Once it has been established that the circuit breaker can be opened and closed normally from the test position, attention can be directed to the trip device proper. Testing is performed by either of two methods:

- 1. Conduct high-current, single-phase tests on the breaker using a high current-low voltage test set.

NOTE: For these single phase tests, special connections must be employed for SST breakers equipped with Ground Fault. Any single-phase input to the ground differential transformer will generate an unwanted "ground fault" output signal which will trip the breaker. This can be nullified either by

- a. testing two poles of the breaker in series, or
- b. Using the Ground Fault Defeat Cable as shown in Fig. 73. This special test cable energizes all the primary windings of the differential transformer in a self-cancelling, series-parallel connection so that its secondary output is always zero.

- 2. Test the components of the SST system using portable Test Set Type TAK-TS1 (Fig. 69). The applicable test procedures are detailed in Instruction Book GEK-64454 and are summarized in Section 8.4.1.

The TAK-TS1 Test Set is a portable instrument designed for field checking the time-current characteristics and pickup calibration of the SST's various trip elements. It can verify the ability of the Flux-Shift Trip device to trip the breaker and, in addition, includes means for continuity checking the phase sensors.

8.4.1—SST Test Set

The TAK-TS1 Test Set is a portable instrument designed to field-check time-current characteristics and pickup calibration of the SST's trip elements. It can verify the ability of the Flux-Shift Trip Device to trip the breaker and includes means for continuity checking phase sensors.

WARNING: BEFORE CONNECTING TEST SET TO BREAKER TRIP DEVICE SYSTEM, ENSURE CIRCUIT BREAKER IS COMPLETELY DISCONNECTED FROM ITS POWER SOURCE. ON DRAWOUT EQUIPMENT, RACK BREAKER TO DISCONNECTED POSITION. VERIFY BREAKER IS TRIPPED.

Either of two test modes may be employed:

"A" - Programmer Unit Only. These tests are conducted with the programmer unit disconnected from the breaker. During test, the unit can remain attached to the breaker or may be completely removed from it.

CAUTION: NEVER DISENGAGE THE HARNESS CONNECTOR FROM THE PROGRAMMER UNIT ON A BREAKER ENERGIZED AND CARRYING LOAD CURRENT. THIS WILL OPEN-CIRCUIT THE CURRENT SENSORS, ALLOWING DANGEROUS, DAMAGING VOLTAGES TO DEVELOP.

Test scope:

- 1. Verify the time-current characteristics and pickup calibration of the various trip elements.
- 2. Verify operation of the SST target indicators on programmer units so equipped.

"B" - Complete Trip Device System. For these tests, the programmer unit must be mounted on the breaker and connected to its wiring harness.

Test scope:

- 1. All "A" tests previously described, plus provision for optionally switching the programmer's output to activate the Flux-Shift Device and verify its operation by physically tripping the breaker.
- 2. Check phase sensor continuity.

In the event that any component of the SST system does not perform within the limits prescribed in test instructions GEK-64454, it should be replaced.

SECTION 8—Type SST Overcurrent Trip Device

8.4.2—Resistance Values

For use in troubleshooting, the Common to Tap resistance for SST current sensors is given in Tables 9 and 10. These values apply to both phase and neutral sensors.

**Table 9—Sensor Resistance Values
AKS 50**

Breaker Frame Size	Ampere Tap	Resistance in ohms between COMMON and TAP Terminals
AKS-50	300	5.3-6.1
	400	7.2-8.2
	600	10.8-12.4
	800	14.6-16.9
	600	6.4-7.6
AKST-50	800	10.2-12.0
	1200	15.8-18.6
	1600	22.0-25.9
	2000	28.5-33.6

**Table 10—Sensor Resistance Values
AKR 75/100**

Breaker	Tap Terminal (AMP)	Tap Lead Color	Resistance in ohms between COMMON terminal (white lead) and TAP terminal
AKR-75	1200	Black	13.4-15.7
	1600	Yellow	18.3-21.5
	2000	Red	23.5-27.6
	3200	Green	42.1-49.5
AKR-100	1600	Black	18.3-21.6
	2000	Yellow	23.5-27.6
	3000	Red	37.7-44.3
	4000	Green	53.4-62.6

The coil resistance of the SST/ECS Flux shifter device is approximately 16 ohms.

8.4.3—False Tripping—Breakers Equipped with Ground Fault

When nuisance tripping occurs on breakers equipped with the Ground Fault trip element, a probable cause is the existence of a false "ground" signal. As indicated by the cabling diagram of Fig. 71 each phase sensor is connected in a series with a primary winding on the Ground Fault differential transformer. Under no-fault conditions on 3-wire load circuits, the currents in these three windings add

to zero and no ground signal is developed. This current sum will be zero only if all three sensors have the same electrical characteristics. If one sensor differs from the others (i.e., different rating or wrong tap setting), the differential transformer can produce output sufficient to trip the breaker. Similarly, discontinuity between any sensor and the programmer unit can cause a false trip signal.

If nuisance tripping is encountered on any breaker whose SST components have previously demonstrated satisfactory performance via the TAK-TS1 Test Set, the sensors and their connections should be closely scrutinized after disconnecting the breaker from all power sources.

- a. Check that all phase sensors are the same type (ampere range).
- b. Ensure that the tap settings on all 3-phase sensors are identical.

8.5—SST Cabling Diagrams

- c. Verify that the harness connections to the sensors meet the polarity constraints indicated by the cabling diagram, i.e., white wire to COMMON, black wire to TAP.
 - d. On Ground Fault breakers serving 4-wire loads, check that the neutral sensor is properly connected (see cabling diagram Fig. 72. In particular,
 1. Verify that the neutral sensor has the same rating and tap setting as the phase sensors.
 2. Check continuity between the neutral sensor and its equipment-mounted secondary disconnect block. Also check for continuity from the breaker-mounted neutral secondary disconnect block through to the female harness connector (terminals L and N.).
 3. If the breaker's lower studs connect to the supply source, then the neutral sensor must have its LOAD end connected to the source.
 4. Ensure that the neutral conductor is carrying only that neutral current associated with the breaker's load current (neutral not shared with other loads).
 - e. If the preceding steps fail to identify the problem, then the sensor resistances should be measured. Since the phase and neutral sensors are electrically identical, their tap-to-tap resistance should closely agree. See Table 9 or Table 10.

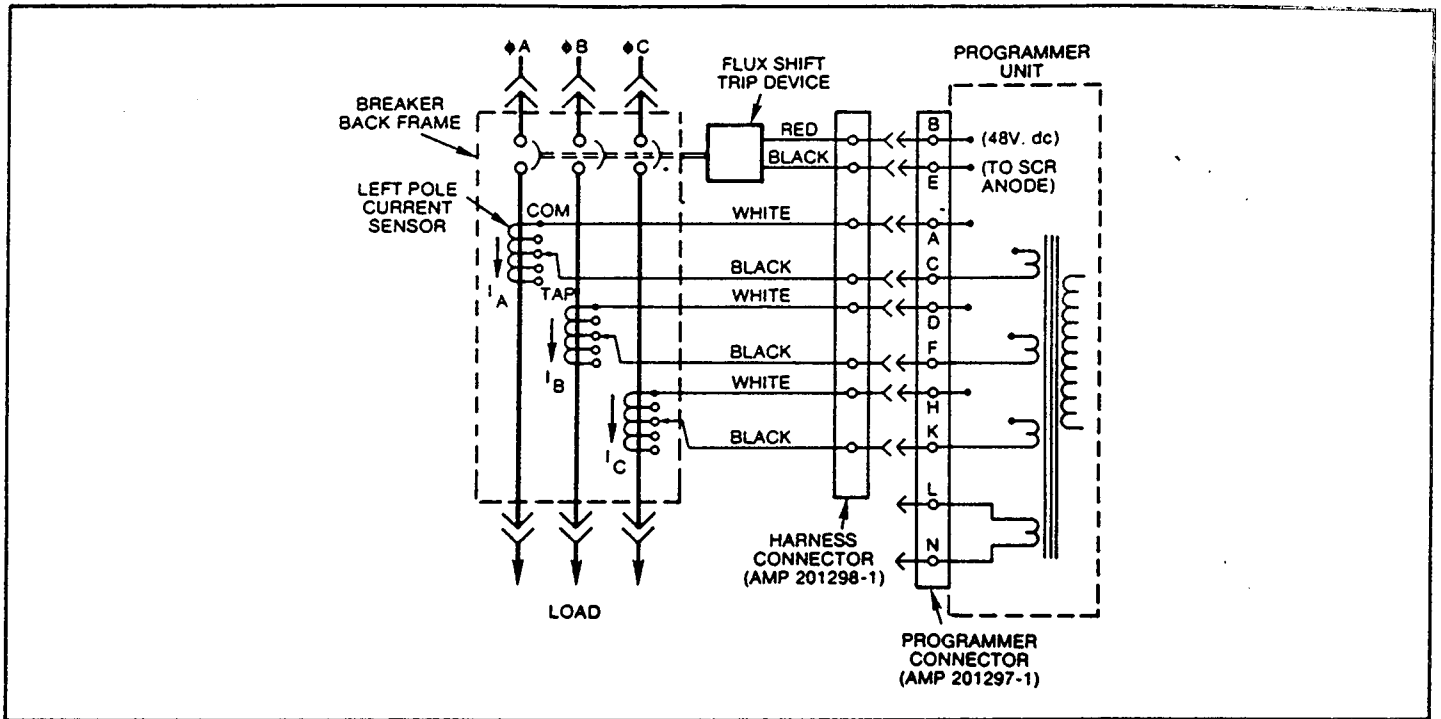

Fig. 70. Cabling diagram—SST without ground fault

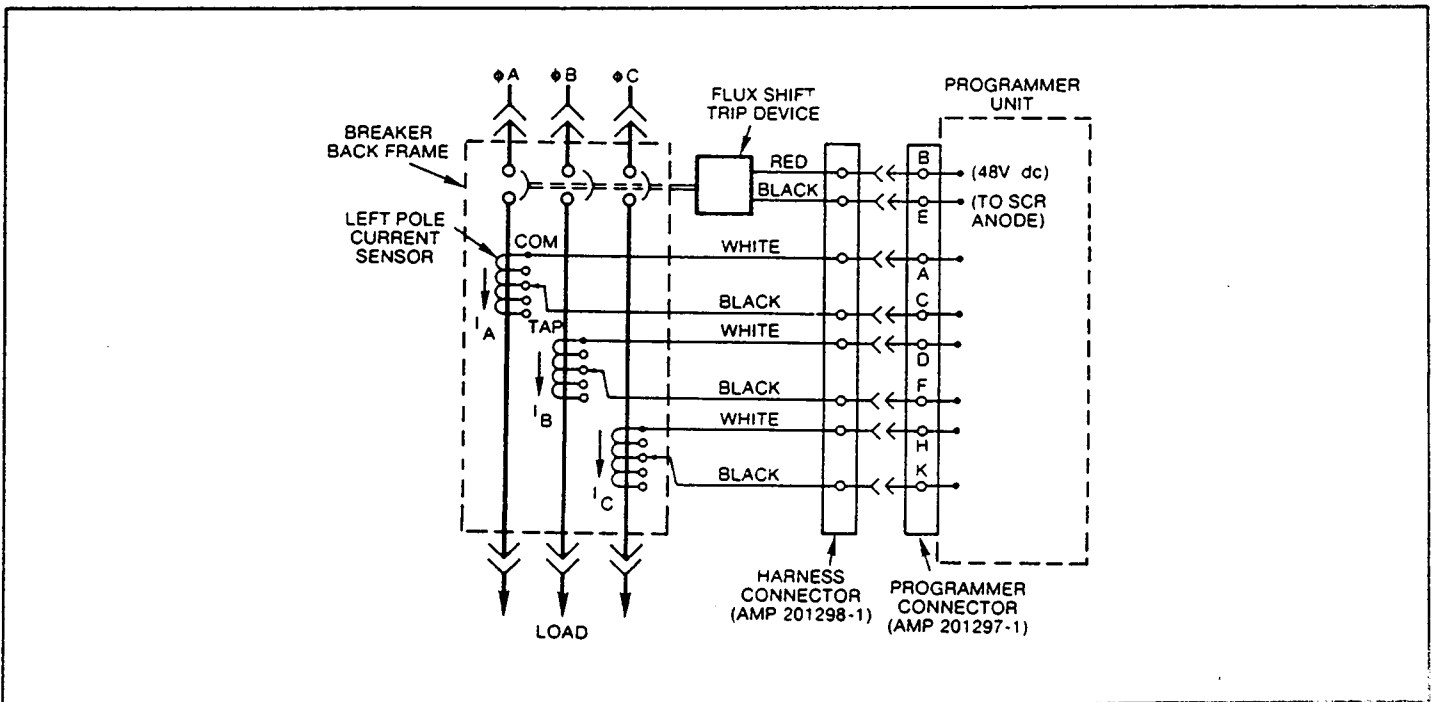

Fig. 71. Cabling diagram—SST with ground fault on 3-wire load

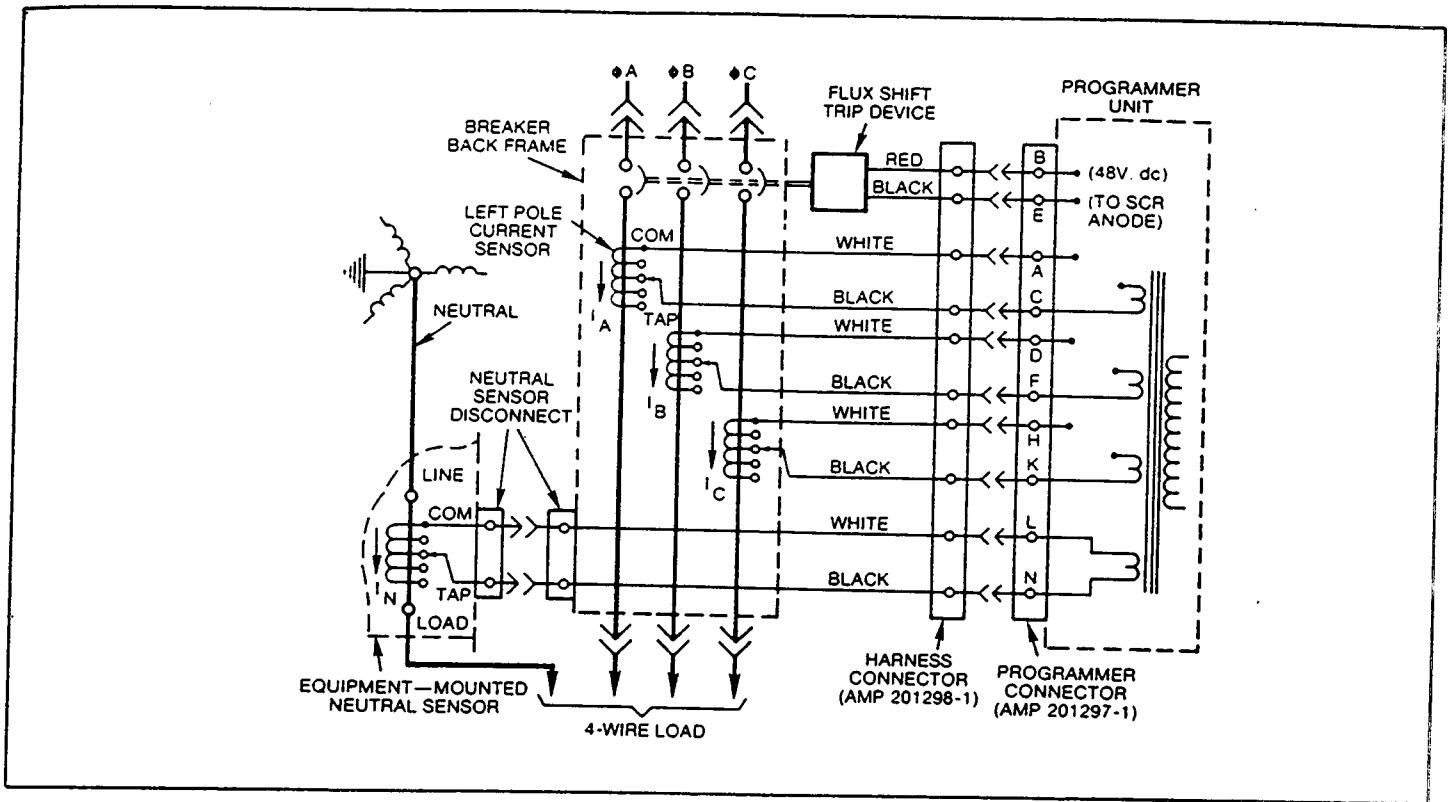

Fig. 72. Cabling diagram—SST with ground fault on 4-wire load

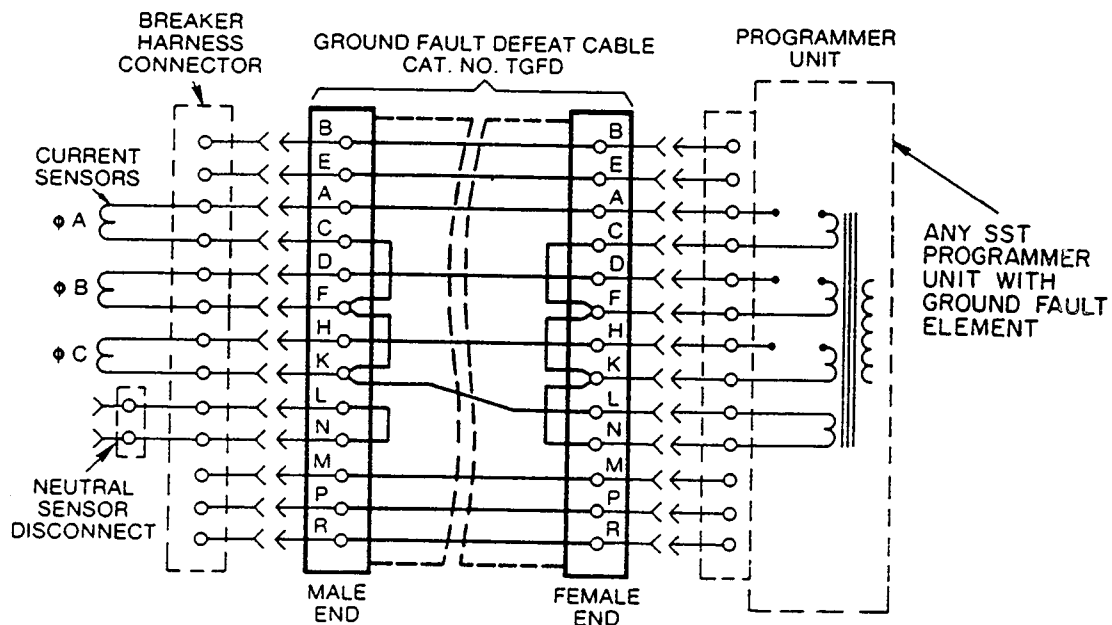

Fig. 73. Cabling diagram with ground fault defeat cable inserted between breaker harness and SST programmer unit—for use during single-phase, high current-low voltage testing

SECTION 9—Type ECS Overcurrent Trip Device

The ECS is a solid-state, direct-acting, self-powered trip device system. The ECS system consists of the ECS programmer unit shown in Fig. 74, current sensors, and a flux shifter trip device. Fig. 75 shows a block diagram of the system.

The ECS trip system essentially duplicates the SST trip system described in Section 8 except for the following:

1. Programmer units are limited to combinations of Long Time, Short Time and Instantaneous trip elements only. The Ground Fault element is not available.
2. Fault indicators (trip targets) are not available.
3. Phase sensors are not tapped. As listed in Table 11 each sensor has only a single ampere rating. A different sensor is available for each of the tabulated ampere ratings, which span the same range as SST, see Fig. 76.
4. Neutral sensors are not required because there is no Ground Fault function.

In all other respects the ECS trip device system operates and can be treated identically to SST. This includes circuitry, size, construction, component location, programmer unit set points, performance characteristics, operating range, quality, reliability and the flux shift trip device. Use the same troubleshooting and test procedures for single-phase, high current-low voltage tests or those employing the TAK-TS1 Test Set. The Ground Fault test procedures, of course, do not apply. ECS phase sensor resistance values are given in Table 12.

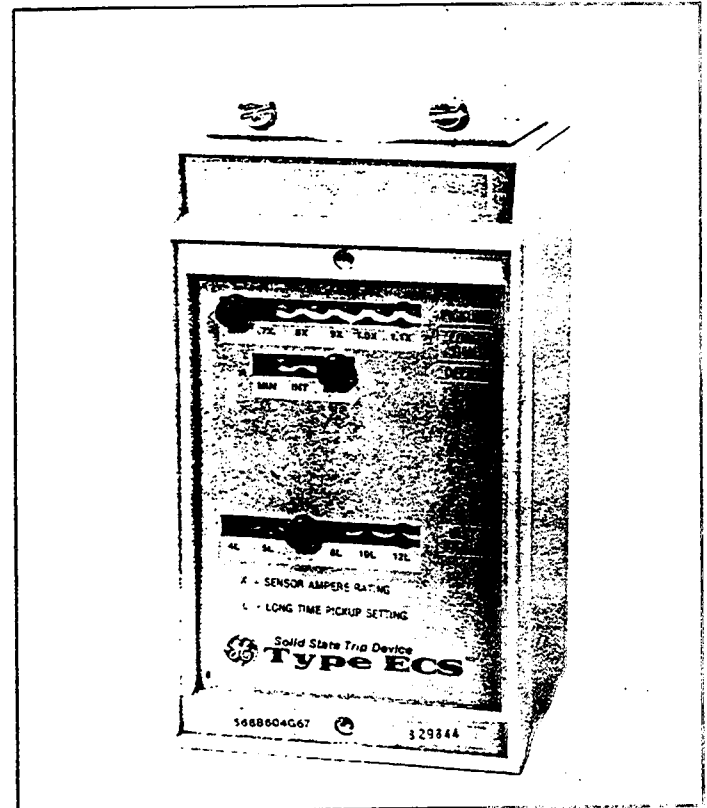

Fig. 74. ESC programmer unit

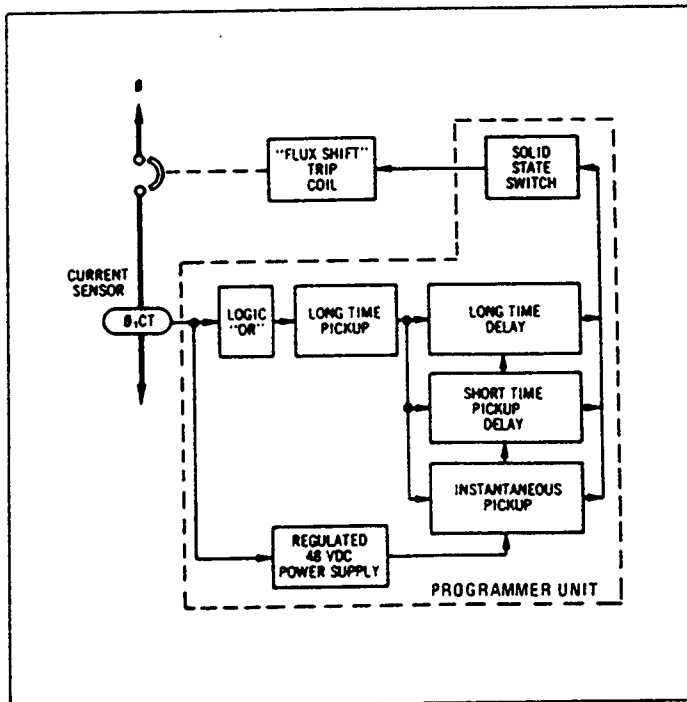

Fig. 75. ECS block diagram

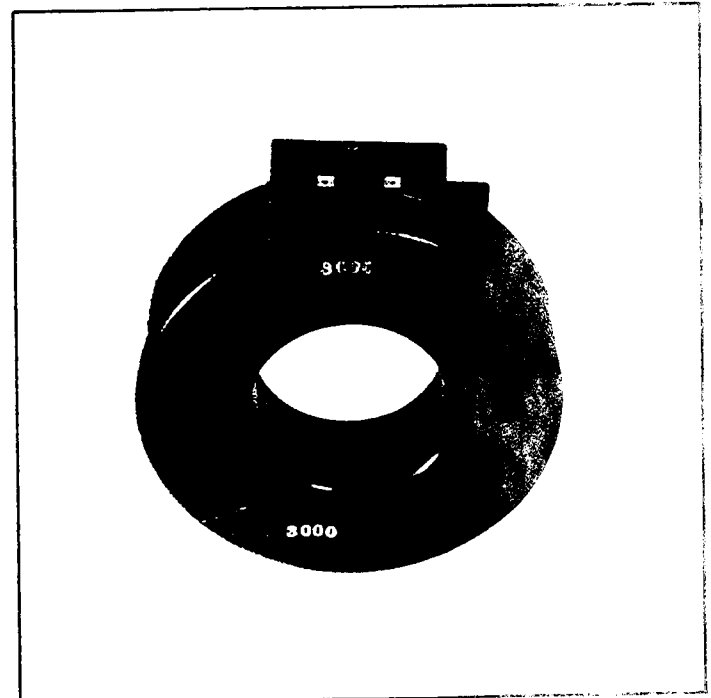

Fig. 76. ECS current sensor

Table 11—ECS Trip Characteristics

Breaker Frame Type	Frame Size (Amperes)	Sensor Ampere Rating (X)	ECS PROGRAMMER ADJUSTMENT RANGE (Set Points)				
			Long Time		Short Time		Instantaneous Pickup (Multiple of L)
			Pickup (L) (Multiple of X)	Delay Band (Seconds)	Pickup (Multiple of L)	Delay Band (Seconds)	
AKS-4/4A-50	1600	300, 400, 600, 800, 1200, 1600	.25, .3, .4 .5, .6, .7 (X)	Maximum 22 Intermed. 10 Minimum 4	1.75, 2, 2.25, 2.5, 3, 4 (L) —or— 0.21	Maximum 0.35 Intermed. 0.21 Minimum 0.095	4, 5, 6, 8, 10, 12 (L)
AKST-4/4A-50	2000	800, 1200, 1600, 2000	.2, .25, .3, .4, .5, .6 (X)				
AK-4/4A-75 AKR-4/4A-75	3000	1200, 1600, 2000, 3000	.6, .7, .8, .9, 1.0, 1.1 (X)				
AKR-4B/4C/4S-75	3200	1200, 1600, 2000, 3000, 3200					
AK-100 AKR-100	400	1600, 2000, 3000, 4000					

NOTES

¹ X = Sensor ampere rating = trip rating.
² Pickup tolerance = ± 10%

³ Time delay at lower limit of band @ 6L.
⁴ Time delay at lower limit of band.

9.1—ECS Cabling Diagram

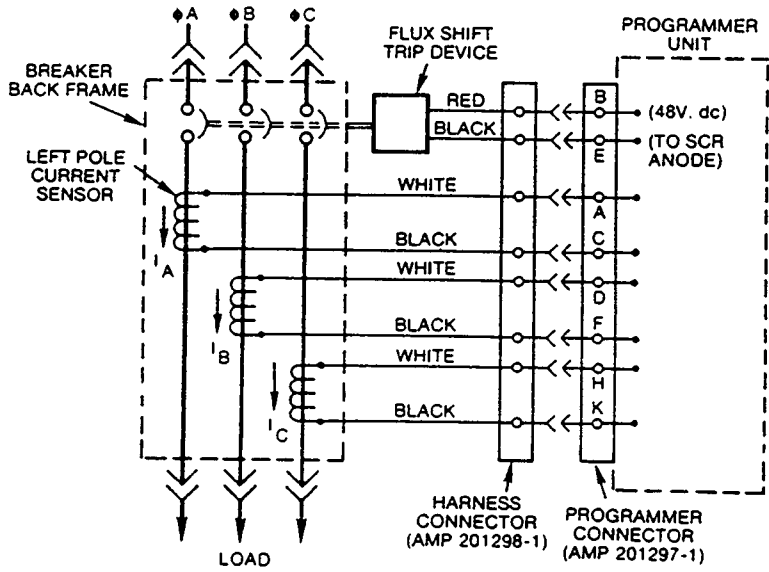

Fig. 77. Cabling diagram for ECS trip device

**Table 12—
Sensor Resistance Values**

Breaker Type	Ampere Rating	Resistance in Ohms Between Terminals
AKS50 AKS750	100	3.0 — 3.4
	150	4.4 — 5.0
	225	4.8 — 5.6
	300	6.4 — 7.2
	400	6.7 — 7.8
	600	6.4 — 7.6
	800	8.8 — 10.4
	1200	13.5 — 15.5
	1600	19.4 — 22.5
	2000	29.5 — 34.5
	1200	13.4 — 15.7
	1600	18.3 — 21.5
	2000	23.5 — 27.6
	3000	37.7 — 44.3
	3200	42.1 — 49.5
	4000	53.4 — 62.6

SECTION 10—MicroVersaTrip™ Overcurrent Trip Device

The MicroVersaTrip is a solid-state, direct-acting, self-powered trip device system. The MicroVersaTrip system consists of the MicroVersaTrip programmer, current sensors, and a flux shifter trip device. Fig. 78 shows a block diagram of the system.

10.1—Programmer Unit

Fig. 79 shows a typical MicroVersaTrip programmer unit. Like the SST and ECS units, the MicroVersaTrip provides the comparison basis for overcurrent detection and delivers the energy necessary to trip the breaker. It contains a programmable microelectronic processor which incorporates nine adjustable time-current functions, three mechanical fault indicators (local and remote), a long-time pickup LED indicator (local and remote) and a zone selective interlocking function. All adjustable programmer functions are automatic and self-contained requiring no external relaying, power supply or accessories. See Table 13 for trip functions available and Table 14 for trip function characteristics. A detailed description of each trip function is given in publication GEA 10265 and GEH 4657.

10.1.1—Fault Trip Indicators

The optional fault trip indicators are similar to the SST indicators. They are mechanical pop-out type for identifying overload or short circuit over-currents faults when breakers are ordered without integral ground fault protection. They are also available to identify overload, short circuit and ground fault trips for breakers supplied with integral ground fault protection.

Each target pops out when its associated trip element operates to trip the breaker. After a trip, the popped target must be reset by hand. However, neglecting to reset does not affect normal operation of any trip element or prevent the breaker from being closed.

10.1.2—Remote Fault Indication

Remote fault indication is available in the form of a mechanical contact which may be incorporated directly into the customer's control circuitry. This is a Normally open contact which is activated when its associated target pops out. When the target is reset, the contact is returned to its open position. Each contact is rated 0.25 amp at 125 VDC and 1.0 amp (10 amp in rush) at 120 VAC.

(Continued page 62)

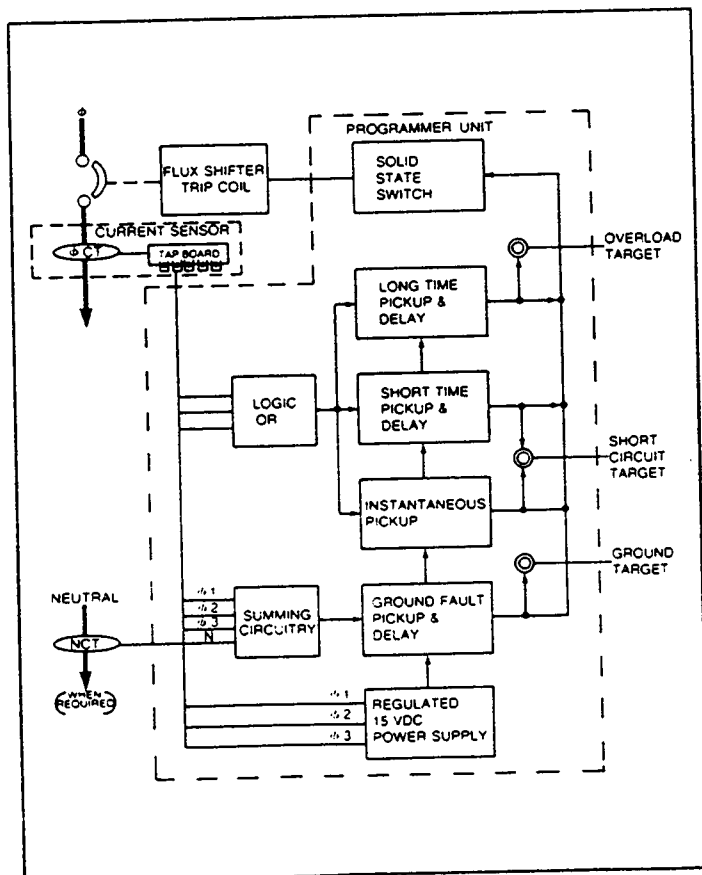

Fig. 78. MicroVersaTrip block diagram

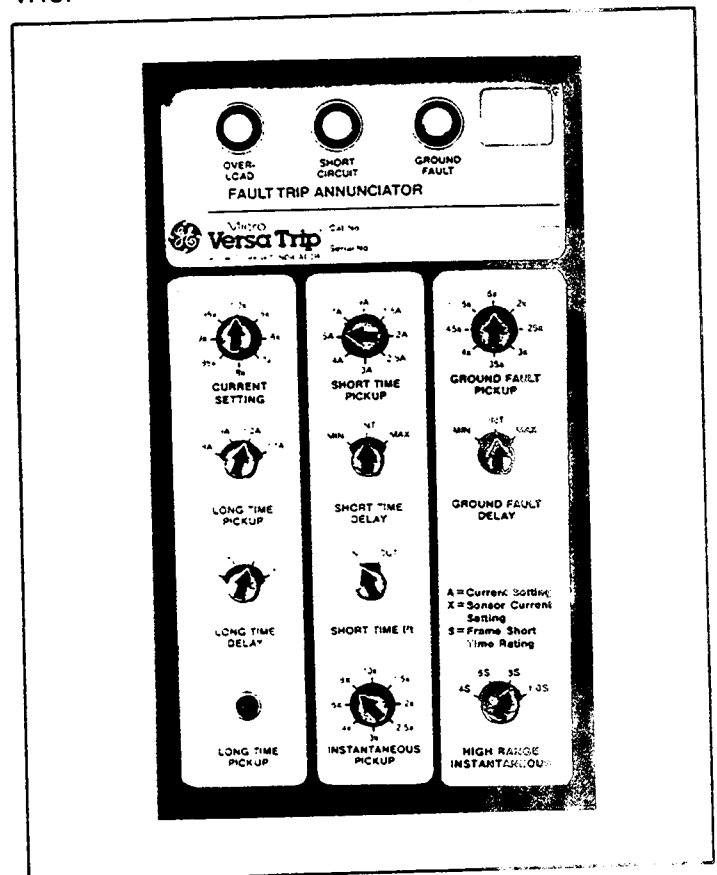

Fig. 79. MicroVersaTrip programmer

Table 13—Trip Functions Available

		Optional Features																			
		BASIC FUNCTIONS				ADD TO BASIC FUNCTIONS															
		STD.-or-S-or-H-or-M	L	T	G-or-GR	A1-or-A2-or-A3-or-A	Z1-or-Z2-or-Z														
LONG TIME	• Adjustable Current Setting	X	X	X	X																
	• Adj Long-Time Pickup	X	X	X	X																
	• Adj Long-Time Delay	X	X	X	X																
	• Long-Time Timing Light	X	X	X	X																
	• Remote Long-Time Timing Light																		X		
SHORT TIME	• Adj Short-Time Pickup		X	X	X																
	• Adj Short-Time Delay		X	X	X																
	• Short-Time I ² t Switch ^①							X													
INSTANTANEOUS	• Adj Instantaneous Pickup	X	X																		
	• Adj High Range Instantaneous			X																	
GROUND FAULT	• Adj Ground Fault Pickup —1 Ph. 2-W—3 PH. 3-W —Ground Return								X		X										
	• Adj Ground Fault Delay								X	X											
	• Trip Indication Targets —Overload & Short Circuit —local only —local and remote —O.L.S.C and Ground Fault —local only ^② —local and remote											X		X						X	
OTHER FUNCTIONS	• Zone Selective Interlock —Ground Fault ^③ —Short Time ^①																		X	X	X

1 Short-Time Delay is required
 2 Standard when Ground Fault specified
 3 Ground Fault required

Table 14—MicroVersaTrip™ Trip Characteristics

Frame Size	Maximum Rating (Amps)	Sensors		Current Setting (Multiple of Sensor Current Rating) (X)	Long-Time		Short-time		Adjustable Instantaneous Pickup (Multiple of Sensor Rating) (X)	Short-time I ² t ^① (Seconds)	Ground Fault	
		(X) Fixed Sensors	(X) Tapped Sensors		Pickup (Multiple of Current Rating) (C)	Delay ^① (Seconds)	Pickup (Multiple of Current Rating) (C)	Delay ^② (Seconds)			Pickup (Multiple of Sensor Current Rating) (X)	Delay ^② (Seconds)
		Sensor Current Rating (Amps)										
AKR-30	800	100, 150, 225, 300, 400, 600, 800	100, 150, 225, 300 or 300, 400, 600, 800	5, 6, 7, 8, 8.5, 9, 9.5, 10 (X)	8, 9, 10, 11 (C)	2.5, 5, 10, 21	1.5, 2, 2.5, 3, 4, 5, 7, 9 (C)	0.10, 0.22, 0.36	1.5, 2, 2.5, 3, 4, 6, 8, 10 (X)	0.4	2, 2.5, 3, 3.5, 4, 4.5, 5, 6 (X)	0.10, 0.22, 0.36
AKR-50 AKS-50	1600	300, 400, 600, 800, 1200, 1600	300, 400, 600, 800 or 600, 800, 1200, 1600
AKST-50 AKRT-50	2000	800, 1200, 1600, 2000	800, 1200, 1600, 2000
AKR-75	3200	1200, 1600, 2000, 3200	1200, 1600, 2000, 3200	2, 2.2, 2.4, 2.6, 2.8, 3.0, 3.4, 3.7 (X)	..
AKR-100	4000	1600, 2000, 3000, 4000	1600, 2000, 3000, 4000	1.5, 2, 2.5, 3, 4, 5, 7, 9 (X)	2, 2.2, 2.4, 2.6, 2.8, 3 (X)	..

1 Time delay shown at 600% of ampere setting at lower limit of each band.
 2 Time delay shown at lower limit of each band.
 All pickup tolerances are ± 10%
 Ground Fault pickup not to exceed 1200 amperes.

C = current setting
 X = sensor current

SECTION 10—MicroVersaTrip™ Overcurrent Trip Device

10.1.2—(Cont.)

The remote fault indication switch leads are brought out the bottom of the MicroVersaTrip programmer as shown in Fig. 80. This switch lead harness is plugged into the mating connector on the breaker, see Fig. 81.

The switch leads are brought out from the breaker through the Programmer Secondary Disconnect shown in Fig. 82. The zone selective interlocking function wiring is also brought out through this disconnect. See Figs. 76 and 77 for the remote fault indication and zone selective interlocking cable diagrams.

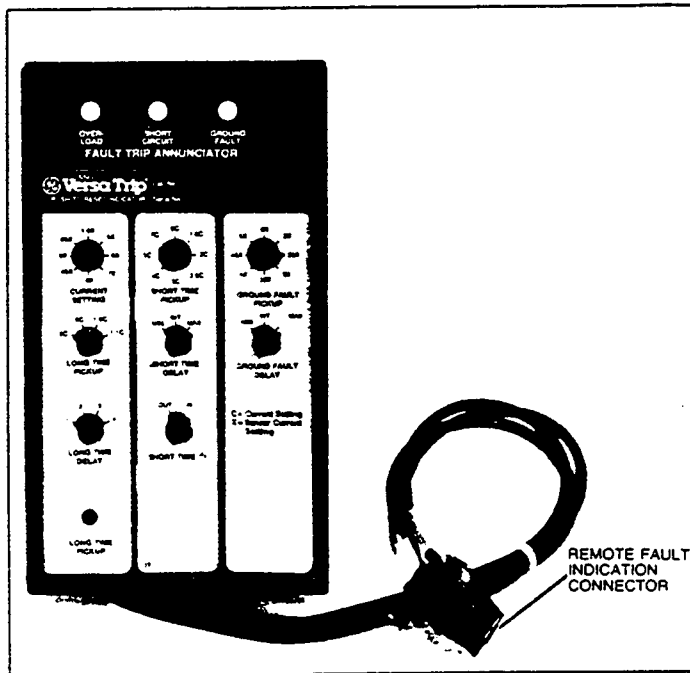

Fig. 80. MicroVersaTrip w/remote fault indication harness

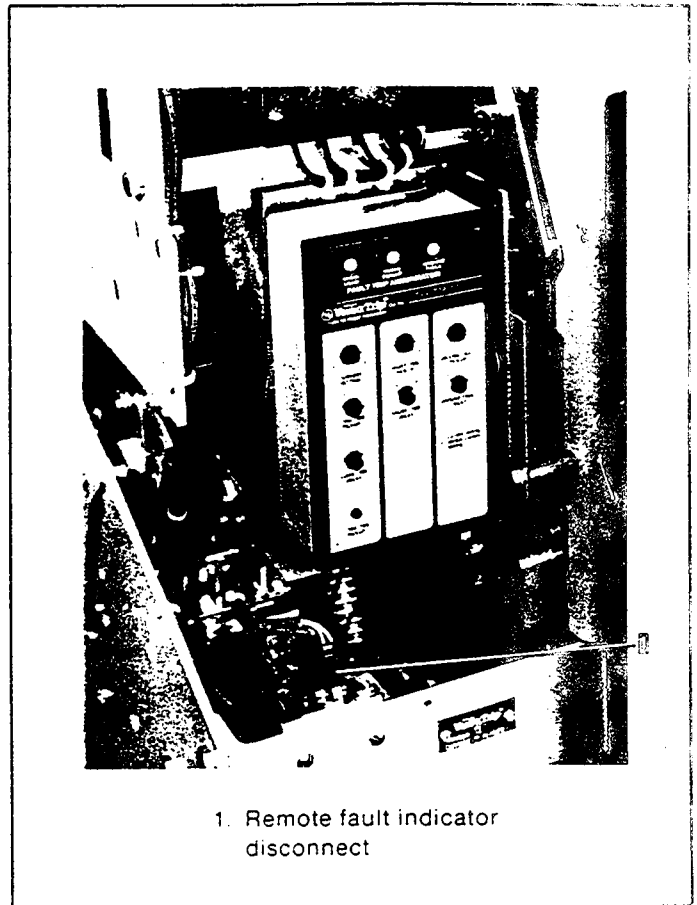

Fig. 81. Remote fault indicator disconnect

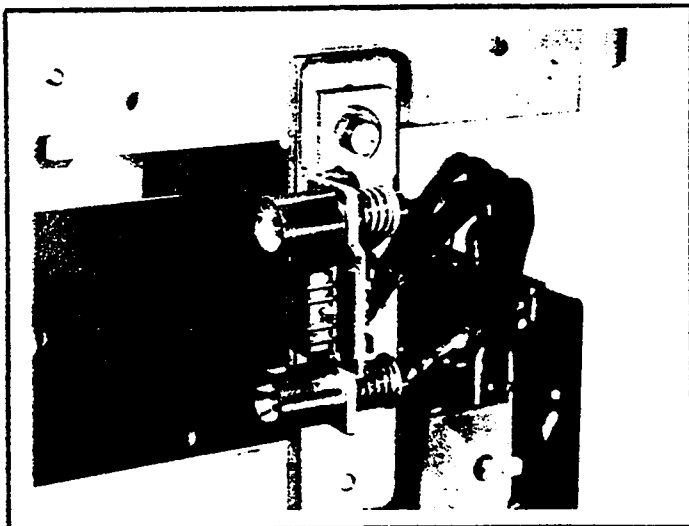

Fig. 82. Programmer secondary connector

10.2—MicroVersaTrip Installation

The programmer is located on the left side of the breaker's center channel as shown in Fig. 81. It mounts to the bracket assembly shown in Figs. 83 or 84. Referring to either Fig. 83 or 84, the guide pins mate with the holes on either side of the programmer connector. They provide the necessary alignment for the connector engagement. The locking lever engages with the pin which is assembled to the programmer frame and secures the programmer to the mounting bracket.

10.2.1—AKS 50 Installation

The AKS 50 mounting bracket is shown in Fig. 83. Installation is as follows:

- a. Insert the guide pins into the holes and push on the programmer. This will engage the connectors and release the locking lever which will move upwards.

- b. Verify that the locking lever did engage the programmer pin.
- c. Connect remote fault indication harness, if equipped, see Fig. 81.

To remove the programmer:

- a. Disconnect remote fault indication harness, if equipped.
- b. Move locking lever to horizontal position, releasing programmer pin.
- c. Remove programmer.

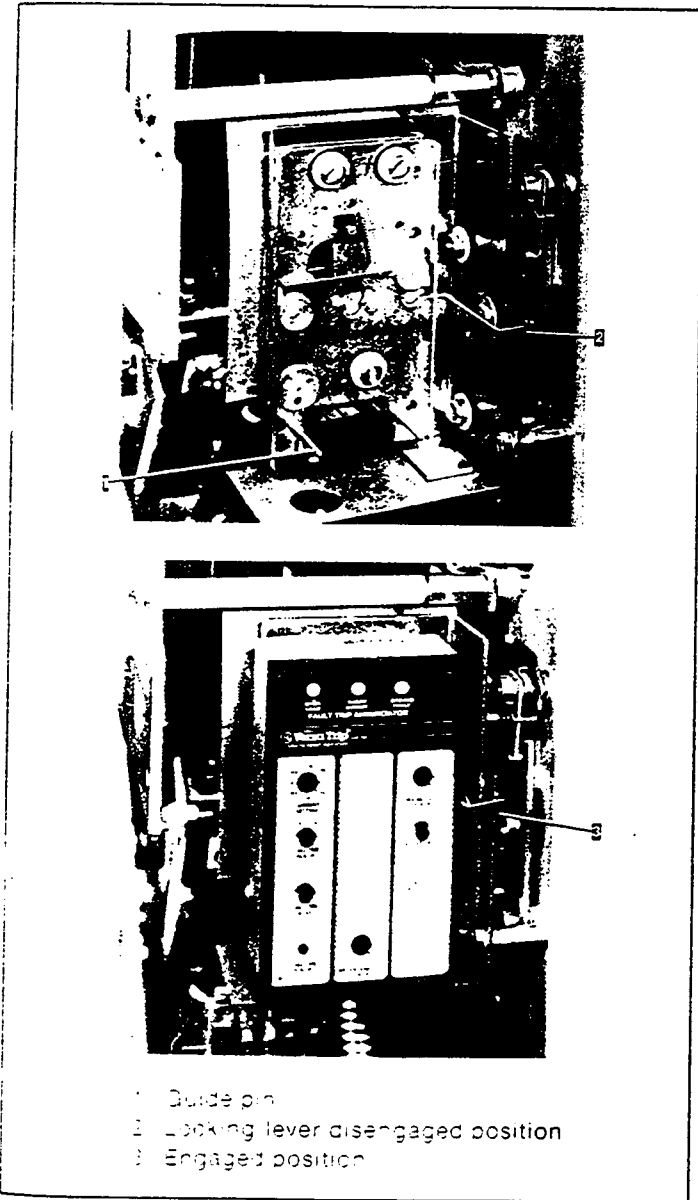

Fig. 83. AKS 50 programmer mounting

10.2.2.—AKR 75/100 Installation

There are two programmer mounting designs in use. The difference in the designs is in the operation of the locking lever, see Fig. 84.

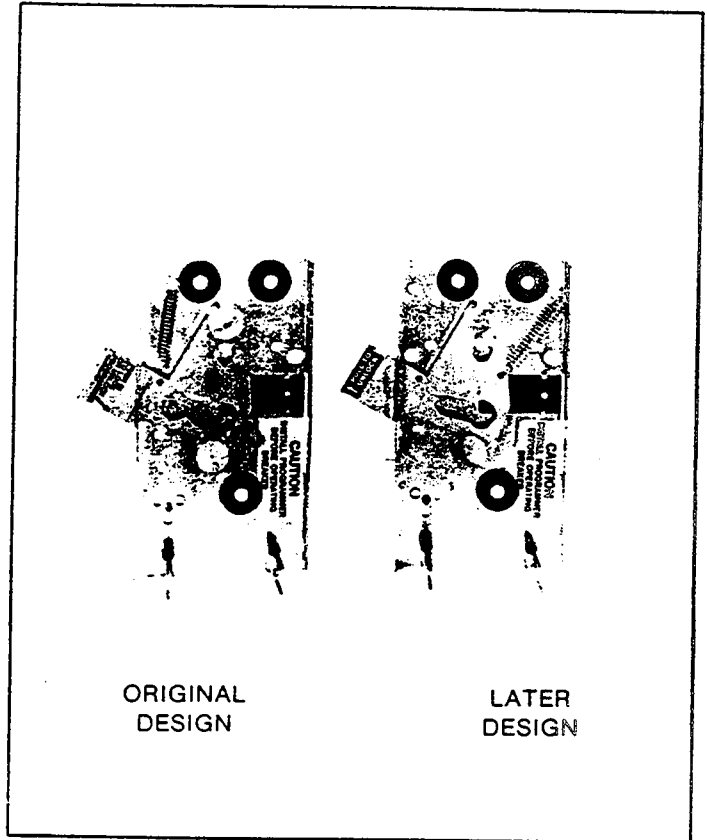

Fig. 84. AKR 75/100 programmer mounting

Installation using each design is as follows:

- a. Insert the guide pins into the holes and push on the programmer, engaging the connectors.
- b. Original design—push in the locking lever, securing the programmer.
Later design—the locking lever is released, securing the programmer.
- c. Verify that the locking lever did engage the programmer pin.
- d. Connect remote fault indication harness, if equipped, see Fig. 81.

To remove the programmer:

- a. Disconnect the remote fault indication harness, if equipped.

(continued next page)

SECTION 10—MicroVersaTrip™ Overcurrent Trip Device

10.2.2—AKR 75/100 Installation (Cont.)

b. Original design—push in locking lever, which will release the programmer pin. While holding the locking lever in, remove the programmer.

c. Later design—pull out locking lever, which will release the programmer pin. Remove the programmer.

10.3—Current Sensors

The current sensors supply the power and signal input necessary to operate the trip system. Like the SST system, the MicroVersaTrip uses a phase and neutral sensor.

Fig. 85 shows the phase sensors. Tapped and fixed phase sensors are available. The tapped sensors provide field adjustment of the trip device's continuous ampere rating. See Section 10.5 for cabling diagrams.

The tapped and fixed phase sensors have a polarity associated with their windings. The COMMON terminal of the tapped sensor and of the AKS 50 fixed sensor is the right hand terminal as shown in Fig. 85. A white wire with a ring terminal will be connected to this COMMON terminal. The AKR 75/100 fixed sensor uses push-on terminals, but the right hand terminal is still the COMMON terminal and uses a white wire.

All phase sensors must be correctly wired for the programmer summing circuitry to function properly. Refer to the cabling diagrams in Section 10.6

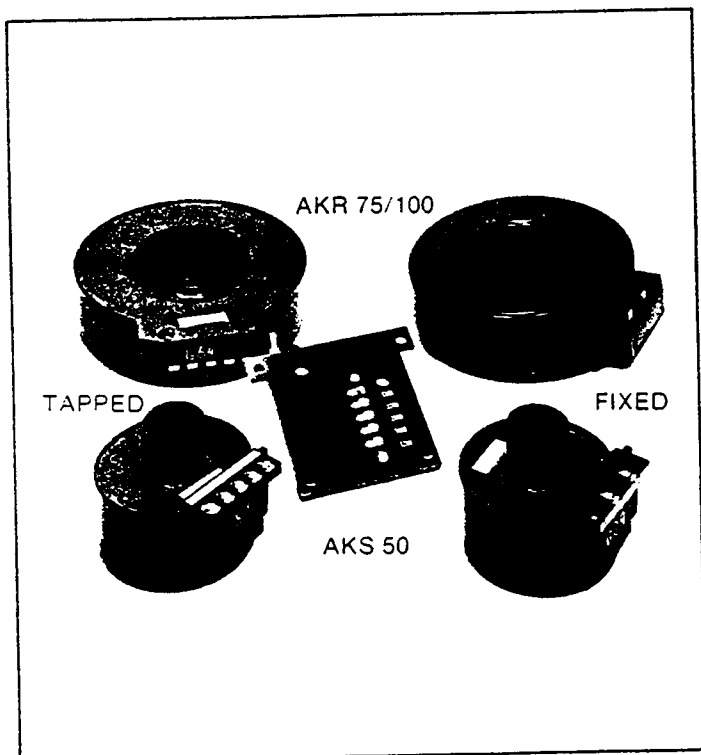

Fig. 85. MicroVersaTrip phase sensors

The tapped or fixed phase sensors are available with an additional winding. This winding is brought out to separate flag terminals rather than the screw terminals. These phase sensors are used when the hi-level instantaneous MicroVersaTrip option ('H'-option) is required. Fig. 86 shows an 'H'-option phase sensor. When the 'H'-option phase sensor is installed, there are four leads connected to it. There is no polarity associated with the 'H'-option windings. Fig. 95 shows the connections for the additional 'H'-option windings.

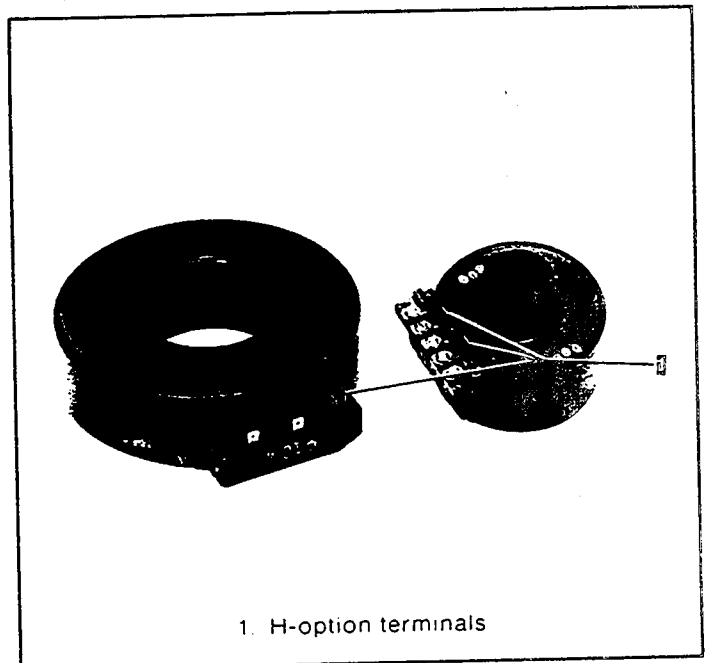

Fig. 86. H-option phase sensor

Fig. 87 shows the neutral sensor. The neutral sensor is required when integral ground fault protection is used on single phase-three wire or three phase-four wire systems. It is inserted into the neutral conductor and therefore is separately mounted in the cable or bus compartment.

The outputs of the phase sensors and neutral sensor are connected to a programmer circuit which sums these values. The total value will remain zero as long as there is no ground current flowing. See cable diagram in Fig. 92.

The neutral sensor is an electrical duplicate of the phase sensor, including taps. Therefore, when taps are changed on the phase sensors, those on the neutral sensor must be correspondingly positioned.

Since the neutral sensor is mounted separately from the breaker, a disconnect means is required to connect its output to the breaker. Fig. 88 shows the breaker and equipment mounted 4th wire secondary disconnect used with the MicroVersaTrip system.

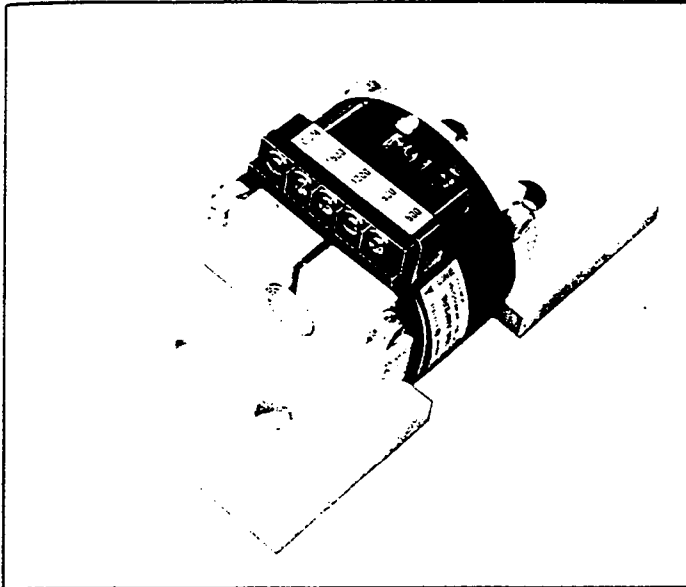

Fig. 87. Typical neutral sensor

10.3.1—Replacement of Current Sensors - AKS 50

The replacement of the AKS 50 MicroVersaTrip current sensors follows the same procedure used for the SST sensors described in Section 8.2.1. The only difference is that the tap board is not a separate item but is integral with the sensor.

10.3.2—Replacement of Current Sensors - AKR 75/100

The replacement of the AKR 75.100 MicroVersaTrip current sensors follows the same procedure used for the SST sensors. refer to Section 8.2.2

10.4—Flux Shifter Trip Device

The only difference between the MicroVersaTrip and SST flux shifter trip devices is the solenoid winding. Refer to Section 8.3 for details.

When replacing a MicroVersaTrip flux shifter, AMP extraction tool Cat. No. 455822-2 is required to remove the socket leads from the AMP connector.

10.5—Troubleshooting

When malfunctioning is suspected, the first step in troubleshooting is to examine the circuit breaker and its power system for abnormal conditions such as:

- a. Breaker tripping in proper response to overcurrents or incipient ground faults.
- b. Breaker remaining in a trip-free state due to mechanical interference along its trip shaft.
- c. Inadvertent shunt trip activations.

WARNING: DO NOT CHANGE TAPS ON THE CURRENT SENSORS OR ADJUST THE PROGRAMMER UNIT SET KNOBS WHILE THE BREAKER IS CARRYING CURRENT.

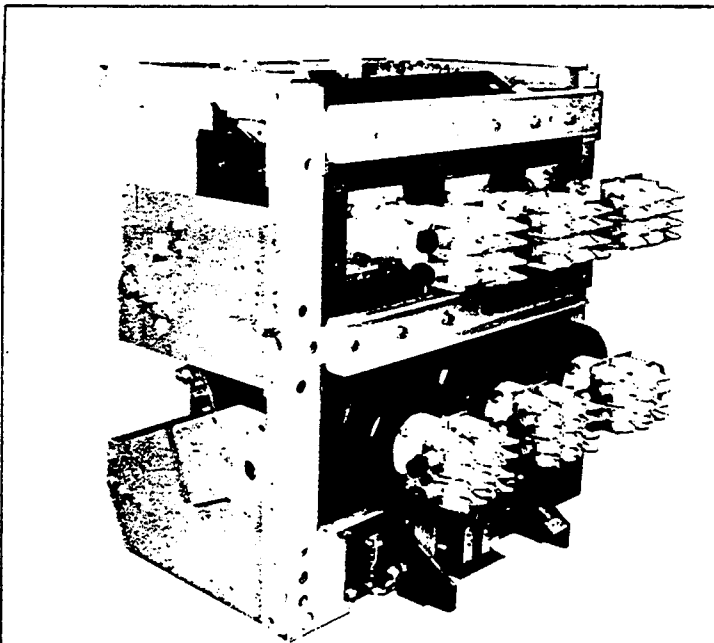

TYPICAL AKR 75/100-AKS 50 REAR MOUNTING

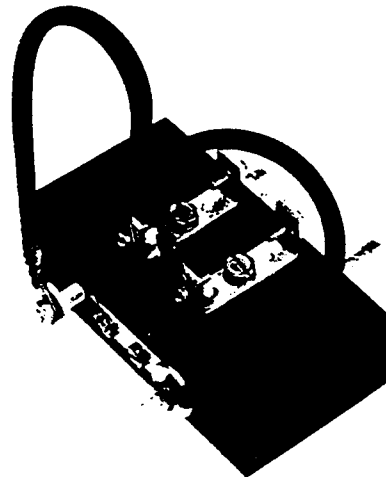

EQUIPMENT MOUNTED MATING DISCONNECT

Fig. 88. Neutral sensor secondary disconnect

SECTION 10—MicroVersaTrip™ Overcurrent Trip Device

10.5—(Cont.)

Once it has been established that the circuit breaker can be opened and closed normally from the test position, attention can be directed to the trip device proper. Testing is performed by either of two methods:

1. Conduct high-current, single-phase tests on the breaker using a high current-low voltage test set.

NOTE: For these single-phase tests, special connections must be employed for MicroVersaTrip breakers equipped with Ground Fault. Any single-phase input to the programmer circuit will generate an unwanted "ground fault" output signal which will trip the breaker. This can be nullified either by

- a. Testing two poles of the breaker in series, or
- b. Using the Ground Fault Defeat Cable as shown in Fig. 94. This special test cable energizes the programmer circuit in a self-cancelling, series-parallel connection so that its output is always zero.

2. Test the components of the MicroVersaTrip system using portable Test Set Type TVS1 (Fig. 89). The applicable test procedures are detailed in instruction Book GEK-64464.



Fig. 89. Test set, cat. no. TVTS1

10.5.1—Resistance Values

For use in troubleshooting the MicroVersaTrip current sensors, the resistance of the tapped and fixed windings is given in Tables 15 and 16 respectively. The coil resistance of the MicroVersaTrip flux shifter device is approximately 7 ohms.

Table 15—Tapped Sensor Resistance Values

Breaker Frame Size	Ampere Tap	Resistance in ohms between Common 2nd Tap Terminals
AKS50	300	CONSULT FACTORY
	400	
	600	
	800	
AKST50	600	
	800	
	1200	
	1600	
AKR75	800	
	1200	
	1600	
	2000	
AKR100	1600	
	2000	
	3000	
	4000	

Table 16—Fixed Sensor Resistance Values

Breaker Frame Size	CT Rating	Resistance in ohms between Common 2nd Tap Terminals
AKS50	300	CONSULT FACTORY
	400	
	600	
	800	
	1200	
AKST50	1600	
	800	
	1200	
	1600	
AKR75	2000	
	1200	
	1600	
	2000	
	3000	
AKR100	3200	
	1600	
	2000	
	3000	
	4000	

10.5.2—False Tripping—Breakers Equipped with Ground Fault

When nuisance tripping occurs on breakers equipped with the Ground Fault trip element, a probable cause is the existence of a false "ground" signal. As indicated by the cabling diagram of Fig. 91, each phase sensor is connected to summing circuitry in the programmer. Under no-fault conditions on 3-wire load circuits, the currents in this circuitry add to zero and no ground signal is developed. This current sum will be zero only if all three sensors have the same electrical characteristics. If one sensor differs from the others (i.e., different rating or wrong tap setting), the circuitry can produce output sufficient to trip the breaker. Similarly, discontinuity between any sensor and the programmer unit can cause a false trip signal.

If nuisance tripping is encountered on any breaker whose MicroVersaTrip™ components have previously demonstrated satisfactory performance via the TVTS1 Test Set, the sensors and their connections should be closely scrutinized after disconnecting the breaker from all power sources.

- a. Check that all phase sensors are the same type (ampere range).
- b. Ensure that the tap settings on all 3-phase sensors are identical.
- c. Verify that the harness connections to the sensors meet the polarity constraints indicated by the cabling diagram.
- d. On Ground Fault breakers serving 4-wire loads, check that the neutral sensor is properly connected (see cabling diagram Fig. 92). In particular,
 1. Verify that the neutral sensor has the same rating and tap setting as the phase sensors.
 2. Check continuity between the neutral sensor and its equipment-mounted secondary disconnect block. Also check for continuity from the breaker-mounted neutral secondary disconnect block through to the female harness connector.
 3. If the breaker's lower studs connect to the supply source, then the neutral sensor must have its LOAD end connected to the source. See Fig. 93.
 4. Ensure that the neutral conductor is carrying only that neutral current associated with the breaker's load current (neutral not shared with other loads).
- e. If the preceding steps fail to identify the problem, then the sensor resistances should be measured. Since the phase and neutral sensors are electrically identical, their tap-to-tap resistances should closely agree. See Tables 15 and 16.

10.6—MicroVersaTrip Cabling Diagrams

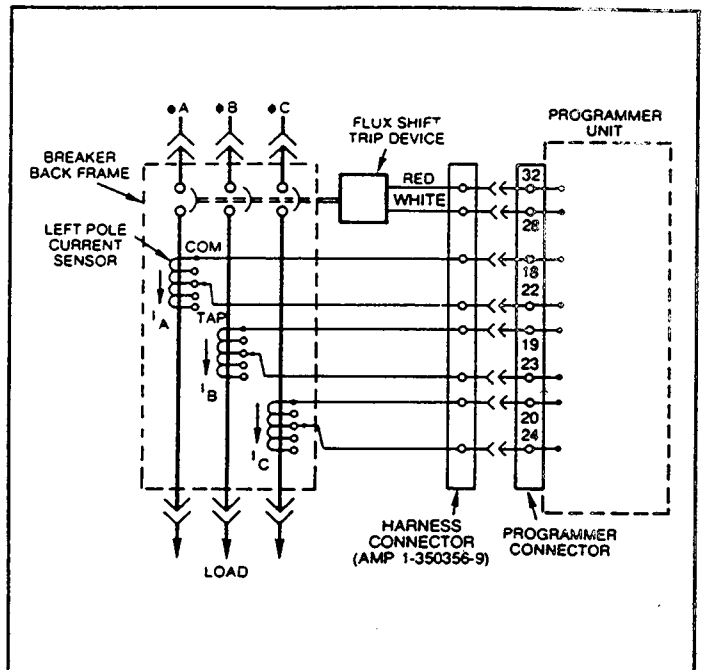

Fig. 90. Cabling diagram—MicroVersaTrip without ground fault

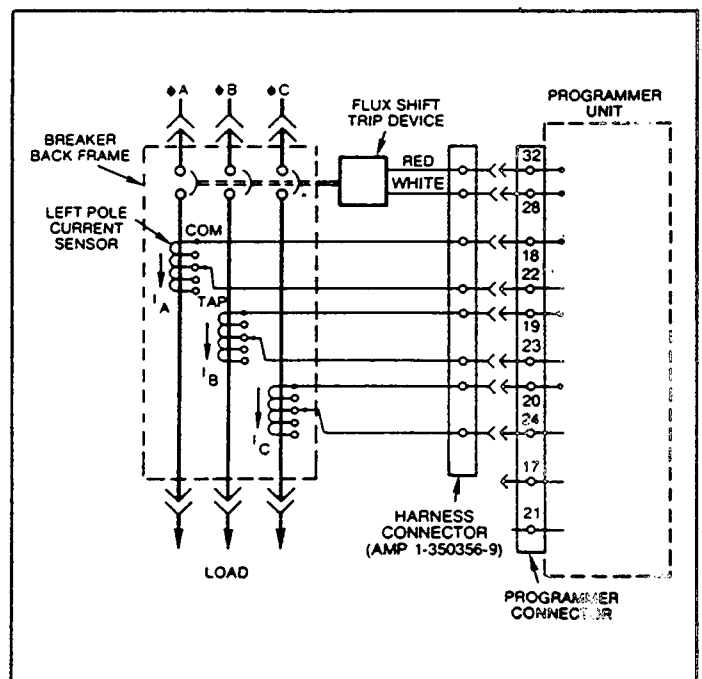

Fig. 91. Cabling diagram—MicroVersaTrip with ground fault on 3-wire load

SECTION 10—MicroVersaTrip™ Overcurrent Trip Device

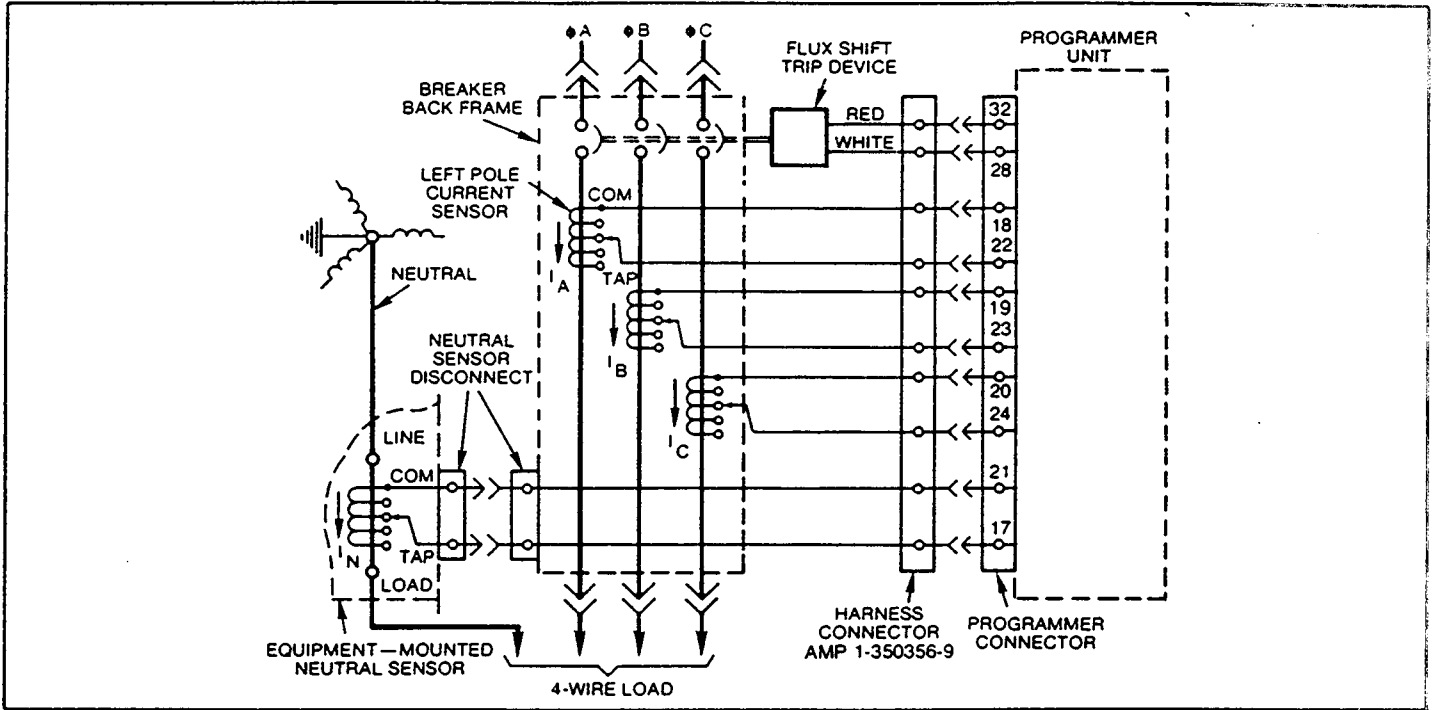

Fig. 92. Cabling diagram—MicroVersaTrip with ground fault on 4-wire load

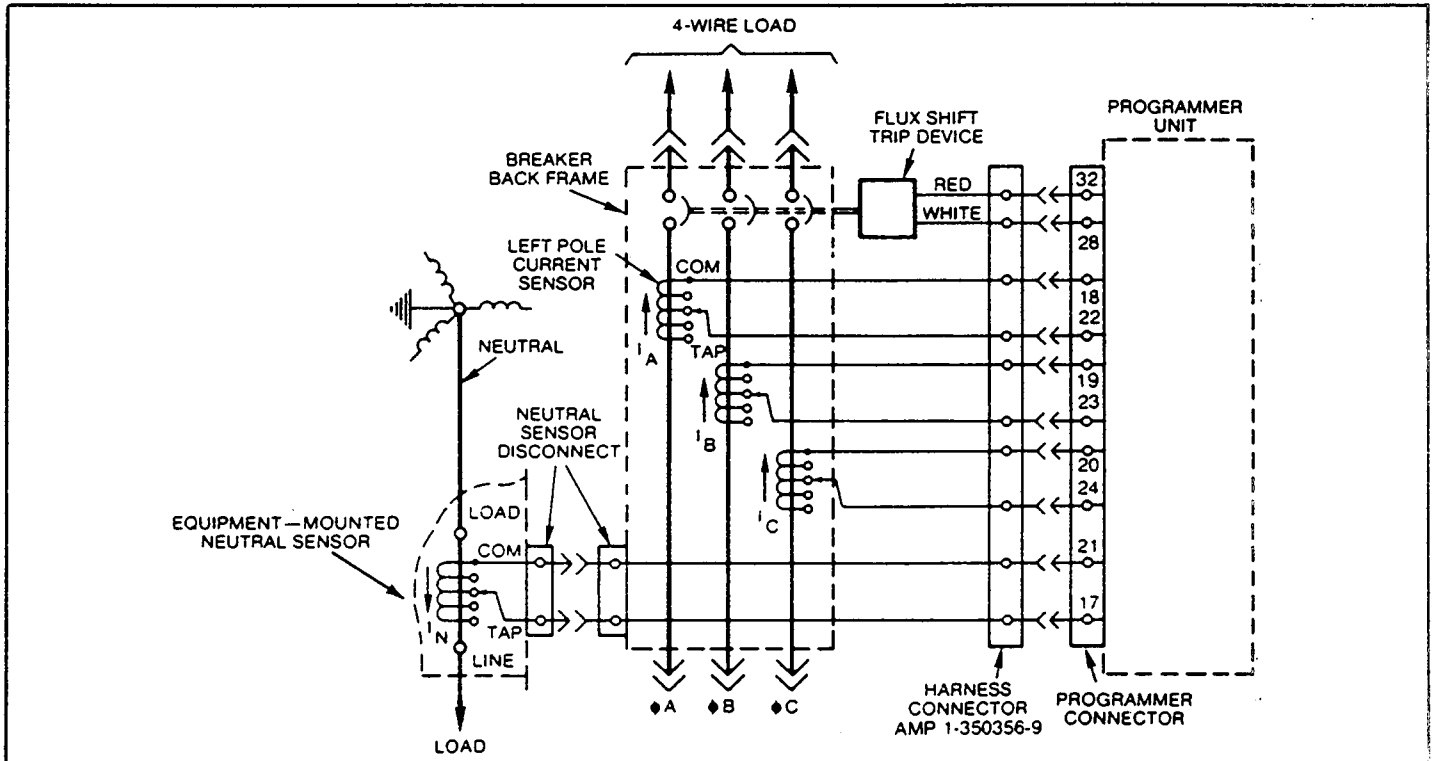

Fig. 93. Cabling diagram—MicroVersaTrip with ground fault on 4-wire load—breaker reverse feed

SECTION 10—MicroVersaTrip™ Overcurrent Trip Device

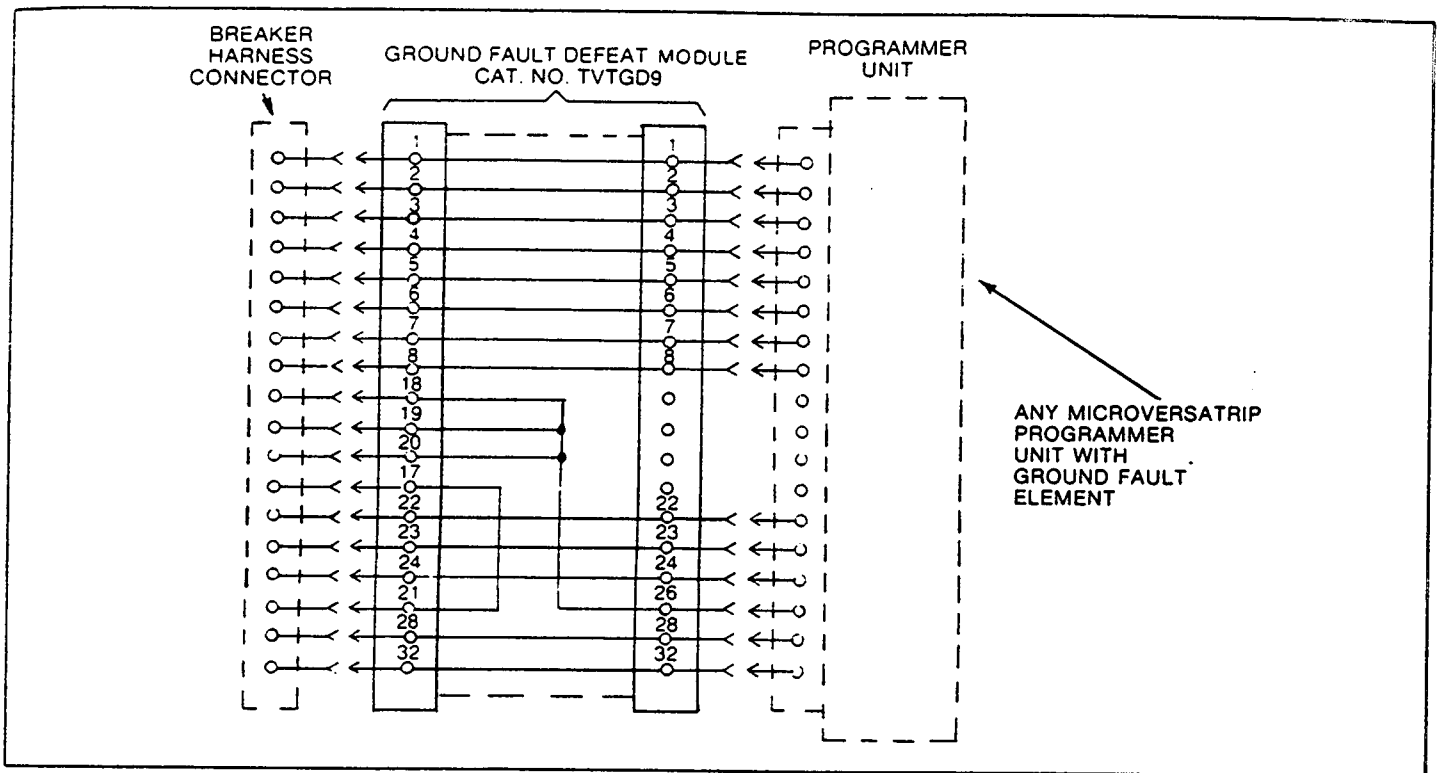

Fig. 94. Cabling diagram with ground fault defeat module inserted between breaker harness and MicroVersaTrip programmer unit—for use during single-phase, high current—low voltage testing

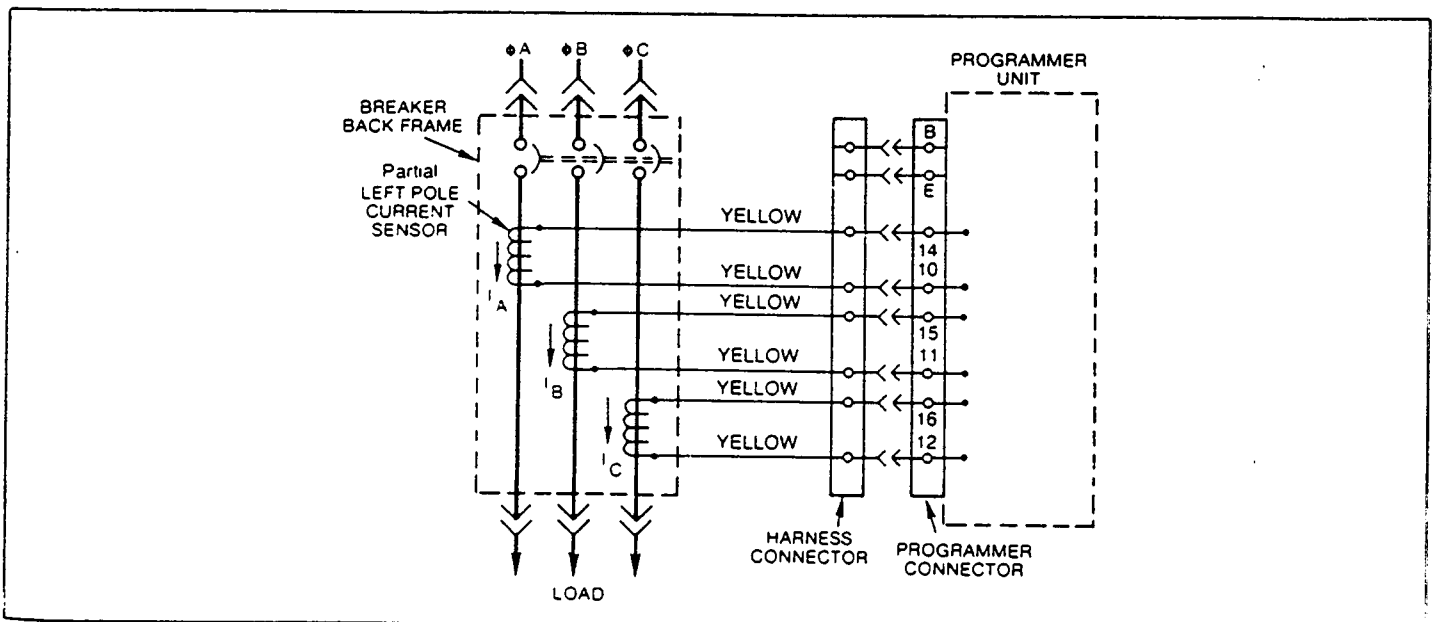

Fig. 95. Partial cabling diagram: 'H'-option winding connections

SECTION 10—MicroVersaTrip™ Overcurrent Trip Device

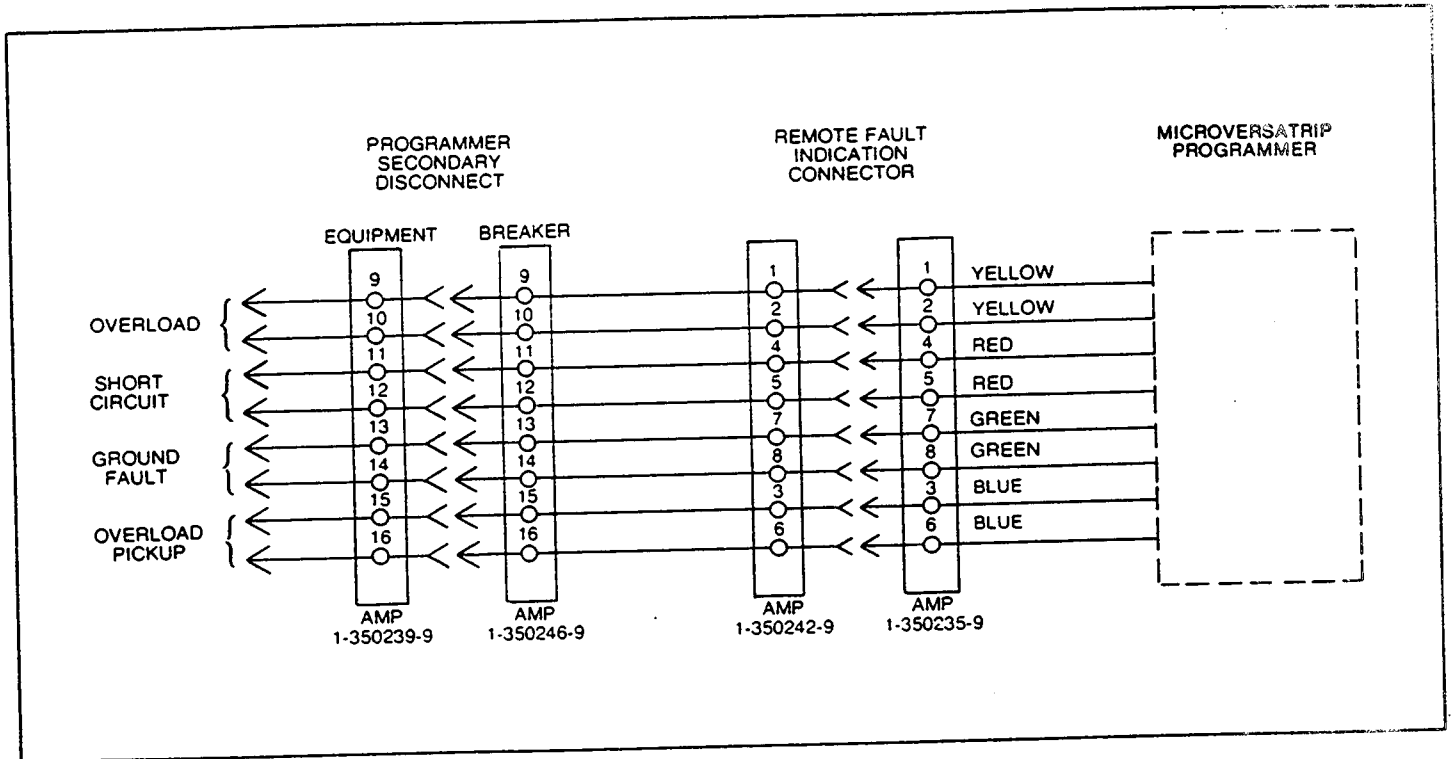

Fig. 96. Cabling diagram—remote fault indication

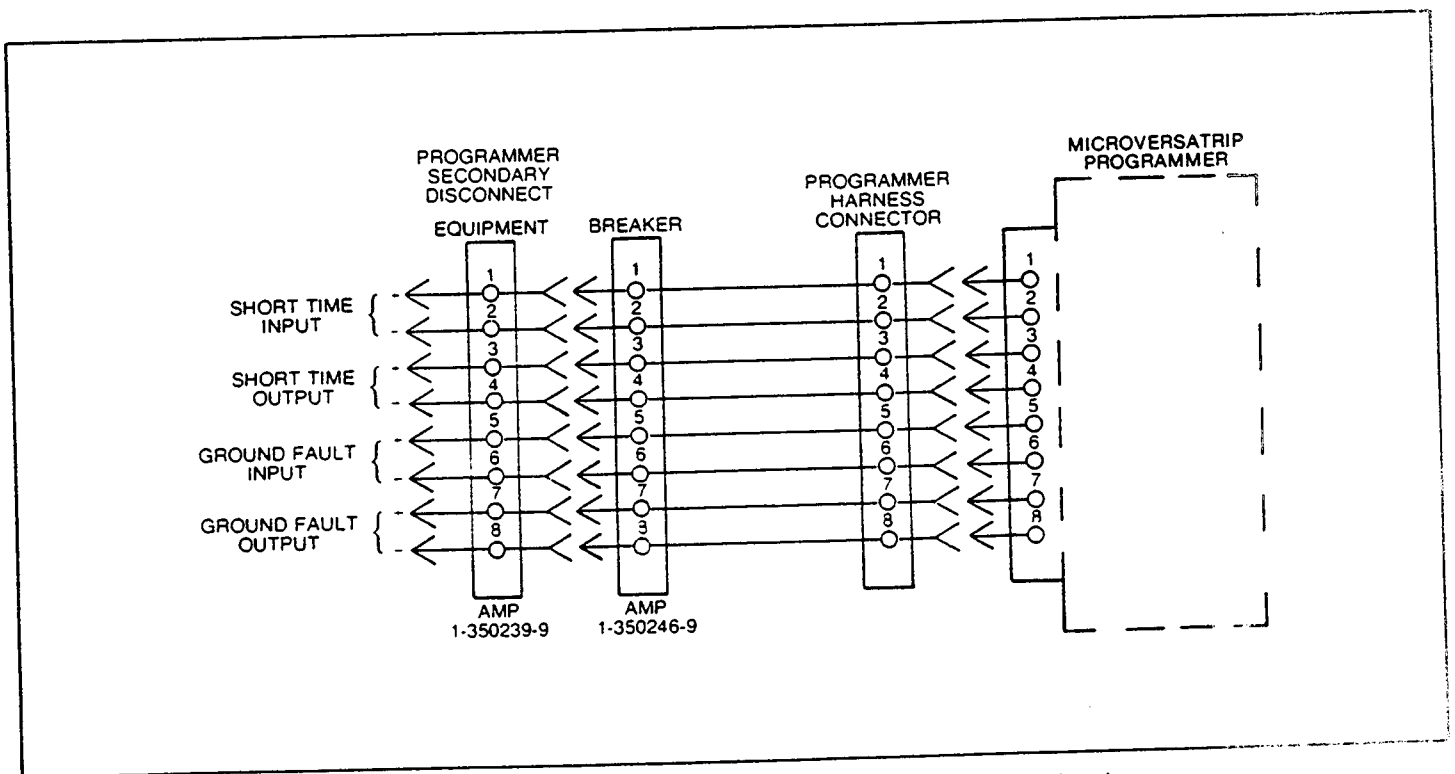

Fig. 97. Cabling diagram—zone selective interlock

SECTION 11—RMS-9/Epic MicroVersaTrip™

The RMS-9/Epic MicroVersaTrip is a solid-state, direct-acting, self-powered trip device system. The RMS-9 system consists of the RMS-9 programmer, current sensors, and a flux shifter trip device. Fig. 98 shows a block diagram of the system.

11.1—Programmer Unit

Fig. 99 shows a typical RMS-9/Epic MicroVersaTrip unit. The RMS-9/Epic MicroVersaTrip provides the comparison basis for overcurrent detection and delivers the energy necessary to trip the breaker. It contains a programmable microelectronic processor which incorporates nine adjustable time-current functions, three mechanical fault indicators, a long-time pickup LED indicator and a zone selective interlocking function. All adjustable programmer functions are automatic and self-contained requiring no external relaying, power supply or accessories. See Table 17 for trip functions available and Table 18 for trip function characteristics. A detailed description of each trip function is given in publication GEK 97367.

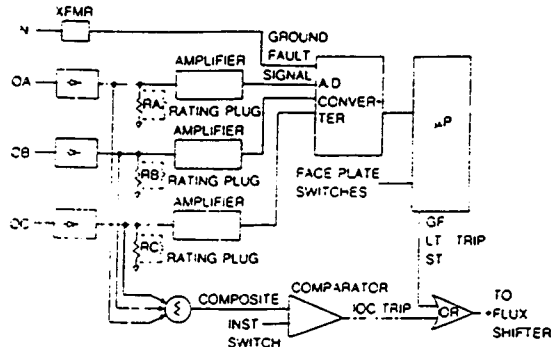

Fig. 98. RMS-9 Block Diagram

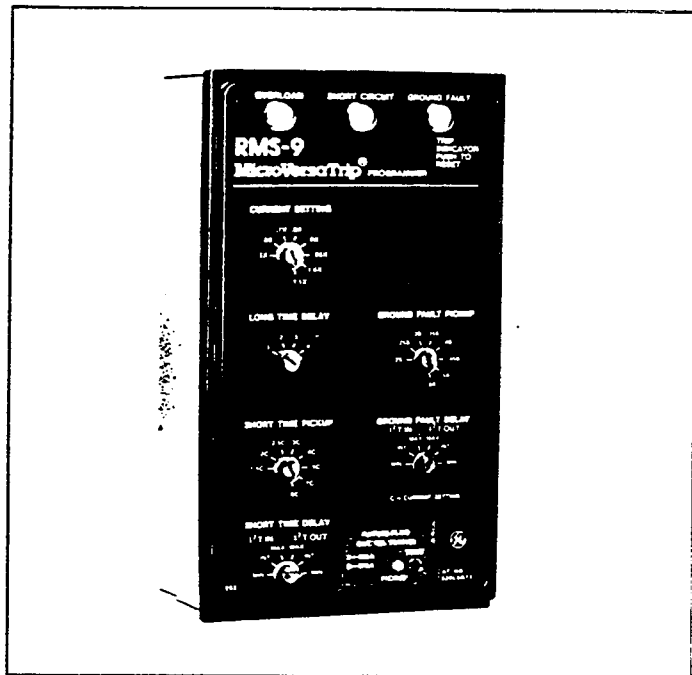

FIG. 99
RMS-9 & Epic MicroVersaTrip
Programmer

11.1.1—Fault Trip Indicators

The optional fault trip indicators are similar to the MicroVersaTrip indicators. They are mechanical pop-out type for identifying overload or short circuit over-current faults when breakers are ordered without integral ground fault protection. They are also available to identify overload, short circuit and ground fault trips for breakers supplied with integral ground fault protection.

Each target pops out when its associated trip element operates to trip the breaker. After a trip, the popped target must be reset by hand. However, neglecting to reset does not affect normal operation of any trip element or prevent the breaker from being closed.

11.2—RMS-9 & Epic MicroVersaTrip

Installation

The programmer mounts to the lower left of the breaker as shown in Fig. 101. It mounts to the bracket assembly shown in Fig. 82. Referring to Fig. 82, the guide pins mate with the holes on either side of the programmer connector. They provide the necessary alignment for the connector engagement. The locking lever engages with the pin which is assembled to the programmer frame and secures the programmer to the mounting bracket.

Installation using each design is as follows:

- Insert the guide pins into the holes and push on the programmer, engaging the connectors.
- The locking lever is released, securing the programmer.
- Verify that the locking lever did engage the programmer pin.

To remove the programmer:

- Pull out locking lever, which will release the programmer pin. Remove the programmer.

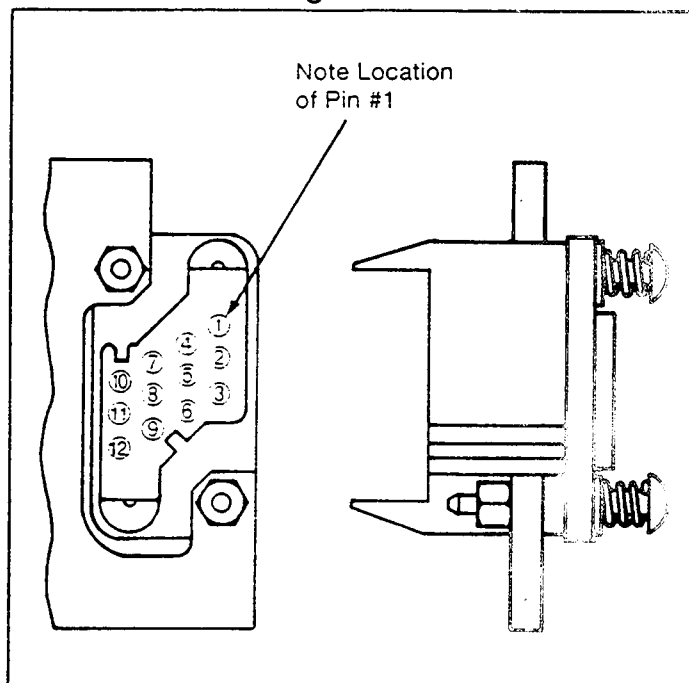

FIG. 100
Programmer Secondary
Connector Epic MicroVersaTrip

SECTION 11—RMS-9 and Epic MicroVersaTrip™ Trip Device

11.3—Current Sensors

The current sensors supply the power and signal input necessary to operate the trip system. The RMS-9 and Epic MicroVersaTrip™ use a phase and neutral sensor. Fig. 102 shows the phase sensors. See Section 11.5 for cabling diagrams.

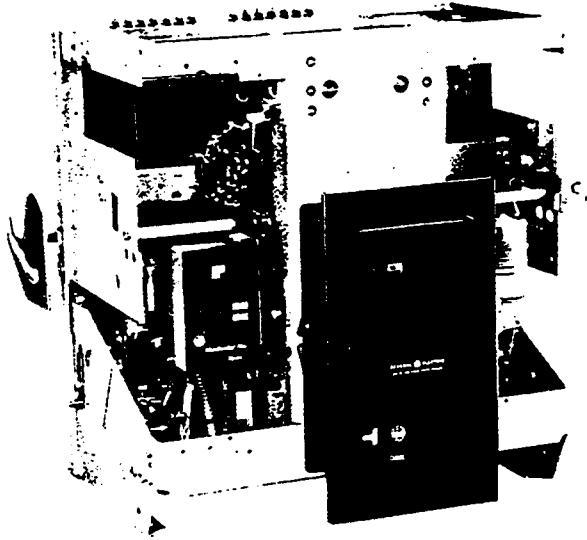

Fig. 101

The fixed phase sensors have a polarity associated with their windings. Their COMMON terminal is the right hand terminal as shown in Fig. 102. A white wire with a push on terminal will be connected to this COMMON terminal. All phase sensors must be correctly wired for the programmer summing circuit to function properly.

The phase sensors are available with an additional winding. This winding is brought out to separate flag terminals. These phase sensors are used when the hi-level instantaneous RMS-9 option ('H'-option) is required. Fig. 102 shows an 'H'-option phase sensor. When the 'H'-option phase sensor is installed, there are four leads connected to it. There is no polarity associated with the special winding connection. Fig. 103 shows the connections for the additional 'H'-option windings.

TABLE 17. TRIP FUNCTIONS AVAILABLE

		Optional Features															
		BASIC FUNCTIONS				ADD TO BASIC FUNCTIONS											
		STD.-or-S-or-H-or-M				L	T	G-or-GR		A1-or-A2-or-A3-or-A		Z1-or-Z2-or-Z					
LONG TIME	• Adjustable Current Setting	X	X	X	X												
	• Adj Long-Time Pickup	X	X	X	X												
	• Adj Long-Time Delay	X	X	X	X												
	• Long-Time Timing Light	X	X	X	X												
	• Remote Long-Time Timing Light						X										
SHORT TIME	• Adj Short-Time Pickup		X	X	X												
	• Adj Short-Time Delay		X	X	X												
	• Short-Time Pt Switch ①					X											
INSTANTANEOUS	• Adj Instantaneous Pickup	X	X														
	• Adj High Range Instantaneous			X													
GROUND FAULT	• Adj Ground Fault Pickup —1PH, 2-W—3PH, 3/4-W —Ground Return								X	X							
	• Adj Ground Fault Delay								X	X							
OTHER FUNCTIONS	• Trip Indication Targets —Overload & Short Circuit —local only —local and remote —O/L, S/C and Ground Fault —local only ② —local and remote										X	X	X	X			
	• Zone Selective Interlock —Ground Fault ③ —Short Time ①														X	X	X

- 1 Short-Time Delay is required
- 2 Standard when Ground Fault specified
- 3 Ground Fault required

TABLE 18. MICROVERSATRIP™ TRIP CHARACTERISTICS

Frame Size	Max. Amp Rating	Sensor Rating (Amps) (S)	Current Setting (Mult. of Rating Plug Amps) (X)	Long-Time		Short-Time		Adjustable Instantaneous Pick Up w/o ST (Mult. of Rating Plug Amps) (X)	Adjustable Instantaneous Pick Up with ST (Mult. of Rating Plug Amps) (X)	High Range Instantaneous (Mult. of Frame Short-time Rating) (H)	Triple Selective Trip Fixed High Range Instantaneous §	Ground Fault		
				Pick up (Mult. of Current Setting) (C)	Delay (Sec.)	Pick up (Mult. of Current Setting) (C)	Delay (Sec.)					Pickup (Mult. of Sensor Amp Rating) (S)	Delay w/ I ² T (Sec.)	Delay § w/o I ² T (Sec.)
AKR-75	3200	3200	5, .6, 7, .8, 9, .95, 1.0, 1.1	Fixed at 1.0 of Current Setting	2.4, 4.9, 9.8, 20	1.5, 2.0, 2.5, 3.0, 4.0, 5.0, 7.0, 9.0	I ² T in: .40 I ² T out: .2	1.5, 2, 3, 5, 7, 9, 10	1.5, 2, 3, 5, 7, 9, 10, 13	.4, .6, .8, 1.0	NA	2, .22, .24, .26, .28, .30, .34, .37	.44 at 200% of pick up at lower limit of band	.10, .21, .35
AKR-100	4000	4000	5, .6, 7, .8, 9, .95, 1.0, 1.1	Fixed at 1.0 of Current Setting	2.4, 4.9, 9.8, 20	1.5, 2.0, 2.5, 3.0, 4.0, 5.0, 7.0, 9.0	I ² T in: .40 I ² T out: .2	1.5, 2, 3, 5, 7, 9	1.5, 2, 3, 5, 7, 9	.4, .6, .8, 1.0	NA	2, .22, .24, .26, .28, .3	.44 at 200% of pick up at lower limit of band	.10, .21, .35

- 1 Time delay shown at 600% of current setting at lower limit of band.
- 2 Time delay shown at lower limit of each band. All pick up tolerances are ± 10%.
- X = Rating plug amps
S = Sensor amp rating
C = Current setting
- § Triple selective trip is standard when long-time/short-time only is required.
- § Time delay shown at lower limit of each band. Ground fault pick up not to exceed 1200 amps.

SECTION 11—RMS-9 and Epic MicroVersaTrip™ Trip Device

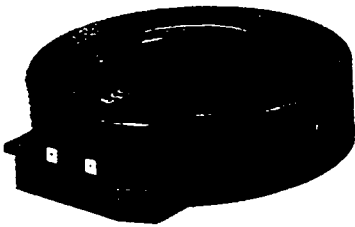

Fig. 102. RMS-9 Phase Sensors

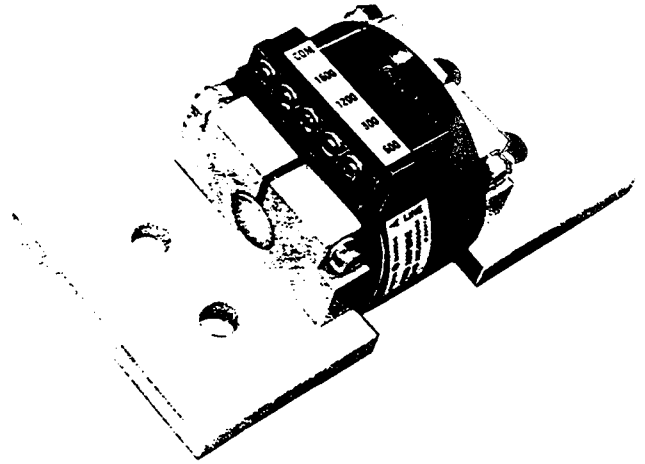

Fig. 104. Typical Neutral Sensor

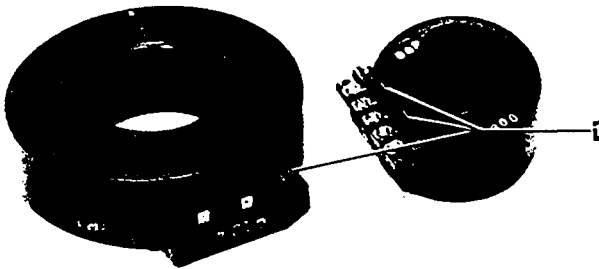

Fig. 103. 'H' Option Phase Sensor

Fig. 104 shows the neutral sensor. The neutral sensor is required when integral ground fault protection is used on single phase-three wire or three phase-four wire systems. It is inserted into the neutral conductor and therefore is separately mounted in the cable or bus compartment.

The outputs of the phase sensors and neutral sensors are connected to a programmer circuit which sums these values. The total value will remain zero as long as there is no ground current flowing. See cable diagram in Fig. 108.

The neutral sensor is an electrical duplicate of the phase sensor. Therefore, when phase sensors are changed, the neutral sensor must be correspondingly changed.

Since the neutral sensor is mounted separately from the breaker, a disconnect means is required to connect its output to the breaker. Fig. 88 shows the breaker and equipment mounted 4th wire secondary disconnect used with the RMS-9 system.

11.3.1—Replacement of Current Sensors

Referring to Fig. 88, replacement of RMS-9 & Epic MicroVersaTrip[®] current sensors is accomplished by the same procedure as the MicroVersaTrip[®] current sensors.

11.4—Flux Shifter Trip Device

The only difference between the RMS-9/Epic MicroVersaTrip[®] and the SST flux shifter trip devices is the solenoid winding. Refer to Section 8.3 for details.

When replacing a RMS-9/Epic MicroVersaTrip[®] flux shifter, AMP extraction tool Cat. No. 455822-2 is required to remove the socket leads from the AMP connector.

11.5—Troubleshooting

When malfunction is suspected, the first step in troubleshooting is to examine the circuit breaker and its power system for abnormal conditions such as:

- a) Breaker tripping in proper response to overcurrents or incipient ground faults.
- b) Breaker remaining in a trip-free state due to mechanical maintenance along its trip shaft.
- c) Inadvertent shunt trip activations.

WARNING: DO NOT ADJUST THE PROGRAMMER UNIT (KNOBS) WHILE THE BREAKER IS CARRYING CUR-

Once it has been established that the circuit breaker can be opened and closed normally from the test position, attention can be directed to the trip device proper. Testing is performed by either of two methods:

1. Conduct high-current, single-phase tests on the breaker using a high current-low voltage test set.

NOTE: For these single-phase tests, special connections must be employed for RMS-9 breakers equipped with Ground Fault. Any single-phase input to the programmer circuit will generate an unwanted "ground fault" output signal which will trip the breaker. This can be nullified either by

- a) Using the Ground Fault Defeat Cable as shown in Fig. 94 This special test cable energizes the programmer circuit in a self-cancelling, series-parallel connection so that its output is always zero.

2. Test the components of the RMS-9 system using portable Test Set Type. The applicable test procedures are detailed in instruction Book 97367.

The time-current characteristics for the RMS-9 & Epic MicroVersaTrip Trip Device are given in curves GES-6227 and GES-6228.

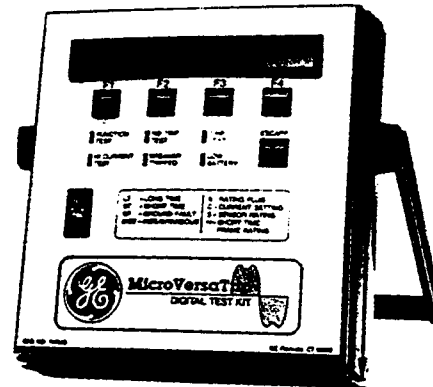

Fig. 105. Test Set, Cat. No. TVRMS

11.5.1—Resistance Values

For use in troubleshooting the RMS-9 current sensors, the resistance of the fixed windings is given in Table 19.

TABLE 19.

Ampere Rating	Resistance in Ohms Between Terminals
150	10-12
400	27-32
800	58-68
1600	129-151
2000	207-243

The coil resistance of the RMS-9 & Epic MicroVersaTrip[®] flux shifter device is approximately 7 ohms.

SECTION 11—RMS-9 and Epic MicroVersaTrip™ Trip Device

11.5.2—False Tripping—Breakers Equipped With Ground Fault

When nuisance tripping occurs on breakers equipped with the Ground Fault trip element, a probable cause is the existence of a false "ground" signal. As indicated by the cabling diagram of Fig. 106, each phase sensor is connected to summing circuitry in the programmer. Under no-fault conditions on 3-wire load circuits, the currents in this circuitry add to zero and no ground signal is developed. This current sum will be zero only if all three sensors have the same electrical characteristics. If one sensor differs from the others (i.e. different rating), the circuitry can produce output sufficient to trip the breaker. Similarly, discontinuity between any sensor and the programmer unit can cause a false trip signal.

If nuisance tripping is encountered on any breaker whose RMS-9 or Epic MicroVersaTrip components have previously demonstrated satisfactory performance via the TVRMS Test Set, the sensors and their connections should be closely scrutinized. After disconnecting the breaker from all power sources.

a) Check that all phase sensors are the same type (ampere range).

b) Verify that the harness connections to the sensors meet the polarity constraints indicated by the cabling diagram.

c) On Ground Fault breakers serving 4-wire loads, check that the neutral sensor is properly connected (see cabling diagram Fig. 108). In particular,

(1) Verify that the neutral sensor has the same rating as the phase sensors.

(2) Check continuity between the neutral sensor and its equipment-mounted secondary disconnect block. Also check for continuity from the breaker-mounted neutral secondary disconnect block through to the female harness connector.

(3) If The breaker lower studs connect to the supply source, then the neutral sensor must have its LOAD end connected to the source. See Fig. 109.

(4) Ensure that the neutral conductor is carrying only that neutral current associated with the breaker load current (neutral not shared with other loads).

e) If the preceding steps fail to identify the problem, then the sensor resistances should be measured. Since the phase and neutral sensors are electrically identical, their tap-to-tap resistances should closely agree. See Table 19.

11.6—Cabling Diagrams

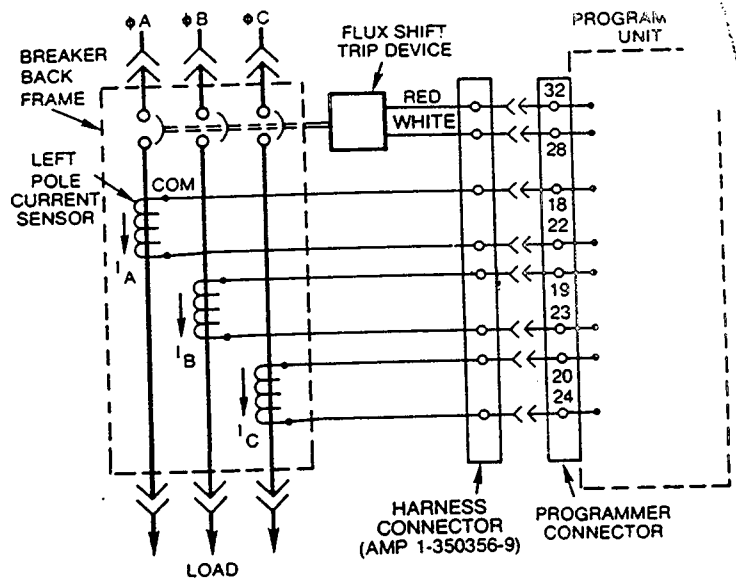

Fig. 106. Cabling diagram—RMS-9 & Epic MicroVersaTrip without ground fault

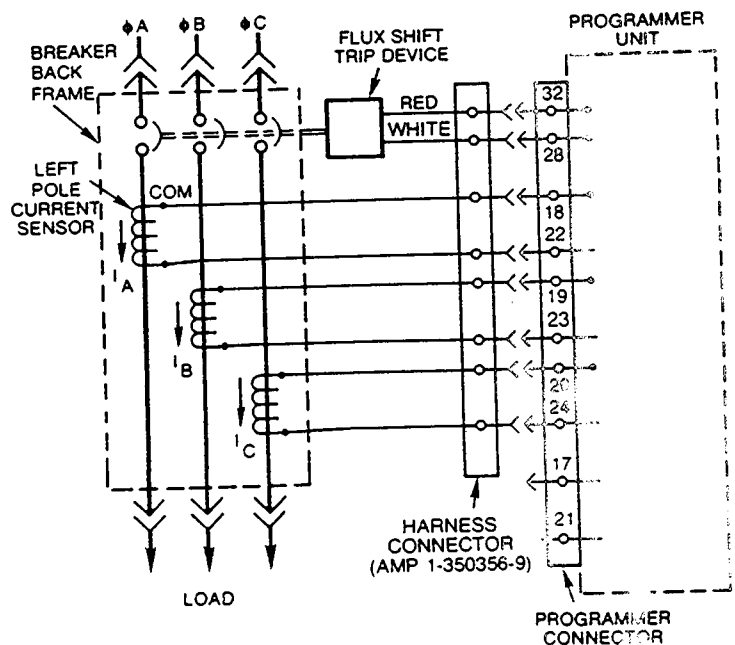

Fig. 107. Cabling diagram—RMS-9 & Epic MicroVersaTrip with ground fault on 3-wire load

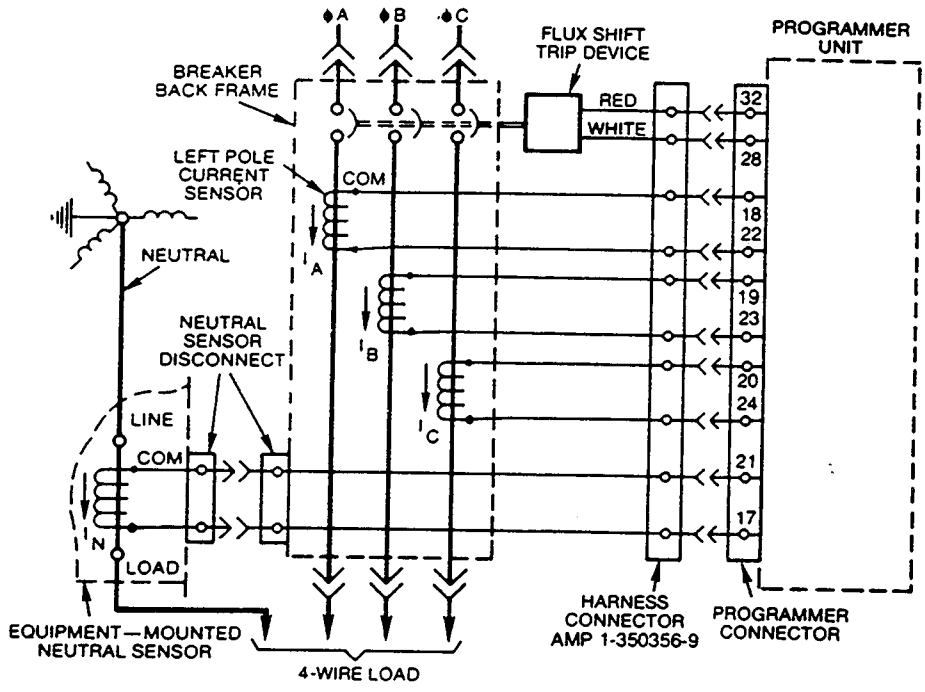

Fig. 108. Cabling diagram—RMS-9 & Epic MicroVersaTrip™ with ground fault on 4-wire load

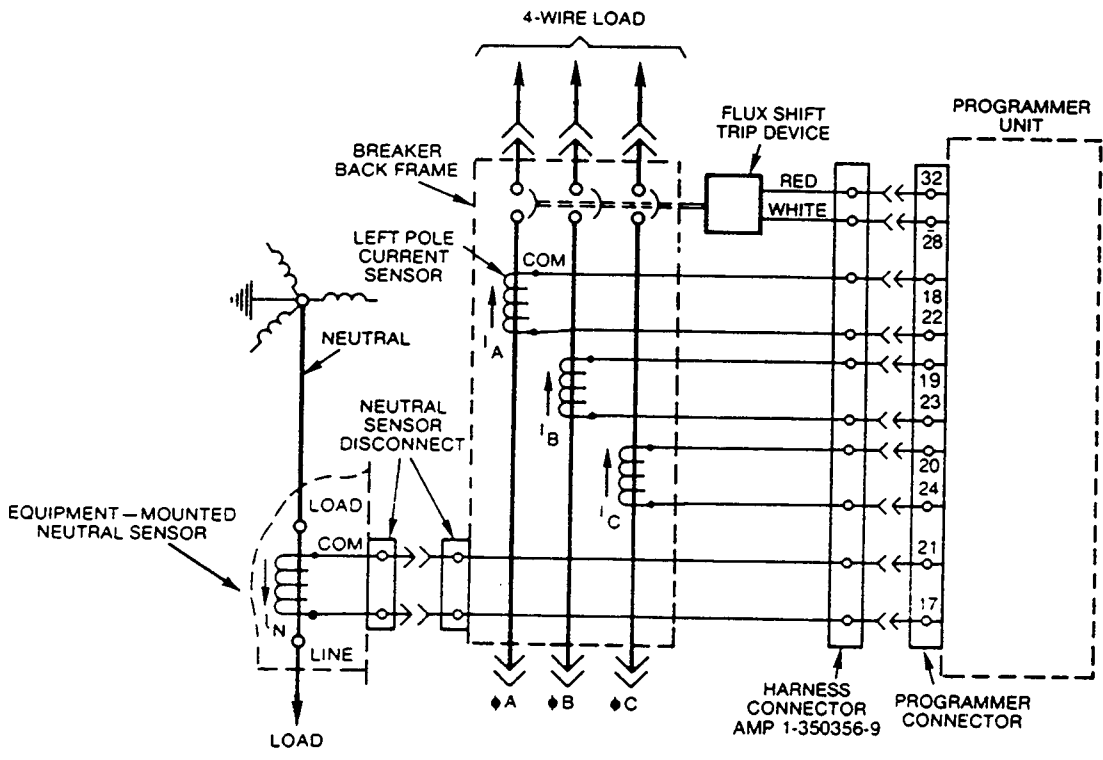

Fig. 109. Cabling diagram—RMS-9 & Epic MicroVersaTrip with ground fault on 4-wire load—breaker reverse feed

SECTION 11—RMS-9 and Epic MicroVersaTrip™ Trip Device

	Socket		
	Class No.		
Zone Selective Interlock	5	+	Gnd. Fault Inputs
	6	-	
	7	+	Gnd. Fault Outputs
	8	-	
Epic MVT	11	-	Commnet
	12	+	
	9	Spare	
	10	VC	
	1	V3	
	4	VA	
	2	24 Ret	
	3	+ 24 VDC	

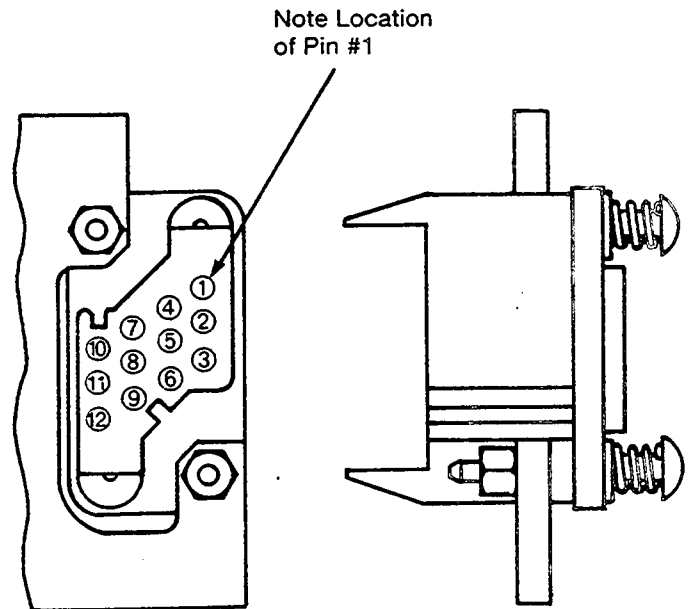

Fig. 110. Programmer secondary connector pin locations for zone selective interlock and Epic MicroVersaTrip Trip Device

SECTION 12—MicroVersaTrip™ Plus and MicroVersaTrip™ PM Trip Units

The MVT-Plus/MVT-PM is a solid-state, direct-acting, self-powered trip device system. The system consists of the MVT-Plus/MVT-PM programmer current sensors and a flux shifter trip device. Figure 111 shows location of features on programmer. See user manual GEH-5891A.

12.1—Trip Unit

MicroVersaTrip Plus Trip Unit

MicroVersaTrip Plus trip units utilize a digital, LCD display with a four-button keypad to provide local set-up and read-out of trip settings. A 3-phase ammeter and trip indicators are standard, as is a clear plastic cover with provisions for sealing to allow tamper resistant installation. The trip unit digitally measures the current waveform in each phase to determine the true RMS value of the current, regardless of the waveshape. MicroVersaTrip⁹ Plus trip units provide accurate, predictable overload and short circuit protection for distribution systems that include ac and dc variable speed drives, rectifiers, induction heating, and other loads that cause high harmonic distortion as well as standard circuit. They provide maximum breaker-to-breaker selectivity and custom load protection. Short time and ground fault functions include the flexibility of coordination with or without an I²t ramp and are also available with high range instantaneous.

MicroVersaTrip PM Trip Unit

MicroVersaTrip PM trip unit adds power management system capability, advanced metering, and protective relays to the basic functions of the MicroVersaTrip Plus. MicroVersaTrip PM trip units communicate directly on the GE POWER LEADER™ communications bus.

Power Requirements

A small amount of power is necessary to energize the liquid crystal display (LCD) during setup, for viewing breaker status, and for metering displays. MicroVersaTrip PM trip units require external 24 Vdc control power for operation. The four sources of such power are the following.

- *Flow of current* – Breaker current sensors provide sufficient power to energize the LCD when at least 20% of the sensor's ampere rating is flowing.
- *24 Vdc control power* – Breakers with MicroVersaTrip PM trip units are supplied with external 24 Vdc power that, whenever present, energizes the LCD. Some breaker models that are configured for MicroVersaTrip Plus trip units may be optionally equipped to accept an external 24 Vdc supply.
- *MicroVersaTrip Test Kit* – The MicroVersaTrip Test Kit, Cat. No. TVRMS, contains a 24 Vdc power supply. The LCD is energized whenever the test kit jack is plugged into the test receptacle on the rating plug.
- *MicroVersaTrip battery pack* – The portable MicroVersaTrip battery pack contains a 24 Vdc power source and a jack. The LCD is energized when the jack is plugged into the rating plug test receptacle.

MicroVersaTrip PM Trip Unit
for Metering, Relaying, and Communication on
AKR Power Circuit Breakers

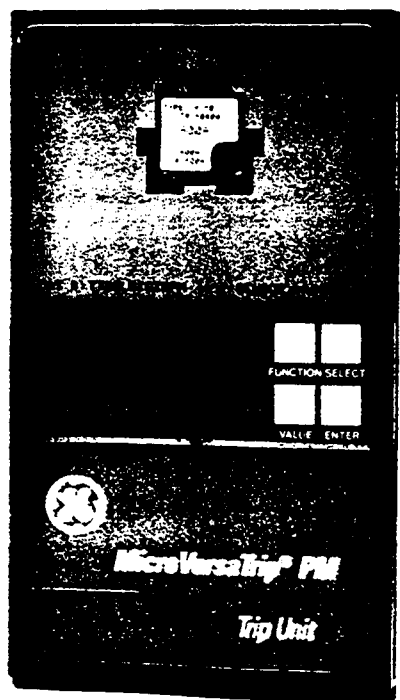

- SELECT** Key chooses next item for display
- ENTER** Key stores options
- VALUE** Key selects phase to display or alter setpoint values
- Interchangeable rating plug for flexibility in matching load requirements
- LCD** readout for metered values, trip settings, and fault trip indication
- FUNCTION** Key selects the mode of display

Fig. 111

SECTION 12—MicroVersaTrip™ Plus and MicroVersaTrip PM Trip Units

12.2—Testing

Testing of MicroVersaTrip Plus and MicroVersaTrip PM trip units may be performed with the trip unit installed in the circuit breaker, the rating plug installed in the trip unit, and the breaker carrying current. The test set catalog number is TVRMS. The test set plugs into the test socket of the rating plug.

Test set TVRMS may also be used for MicroVersaTrip RMS-9 and Epic MicroVersaTrip trip units. Refer to the Maintenance and Troubleshooting section for additional details.

12.3—Product Structure

MicroVersaTrip Plus and MicroVersaTrip PM trip units are removable. Figures 112 and 113 contain front and rear views of a MicroVersaTrip PM trip unit.

Figure 113 shows the 36-pin plug that connects either trip unit to the circuit breaker and equipment circuitry. This plug is called the trip unit disconnect.

CAUTION: Removal of a trip unit from its breaker must be performed with the breaker in the OPEN or TRIPPED position. Draw-out breakers should be racked out first.

CAUTION: Do not attempt to operate the breaker without its assigned trip unit. Installation of an incorrect trip unit may result in unsafe operation of the breaker.

CAUTION: Removal of the rating plug while the breaker is carrying current reduces the breaker's current-carrying capacity to approximately 25% of the current sensor rating. This may result in undesired tripping.

NOTE: Trip units as received may have settings that are undesirable for the specific application. Ensure that settings are appropriately adjusted before energizing.

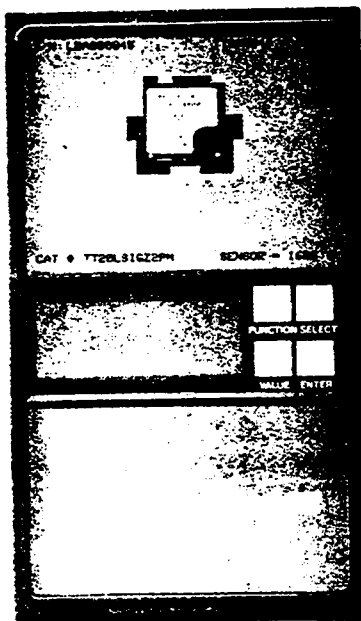

Fig. 112. Front view of MicroVersaTrip PM Trip Unit.

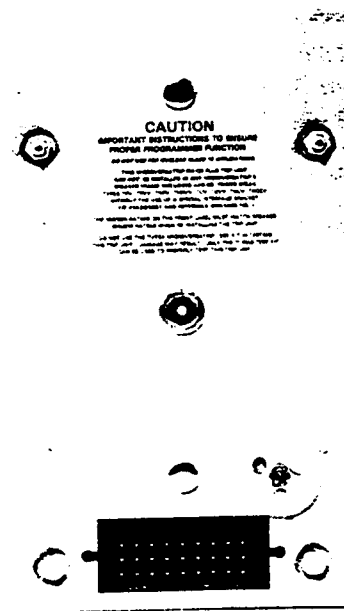

Fig. 113. Rear view of MicroVersaTrip PM Trip Unit.

12.4—Trip Unit Removal and Replacement

The programmer mounts to the lower left of the breaker as shown in Fig. 101. It mounts to the bracket assembly shown in Figs. 83 and 84. Referring to Fig. 83, the guide pins mate with the holes on either side of the programmer connector. They provide the necessary alignment for the connector engagement. The locking lever engages with the pin which is assembled to the programmer frame and secure the programmer to the mounting bracket. When a trip unit is replaced, the locking arm snaps back into place to indicate proper engagement.

WARNING: Always de-energize Type AKR circuit breakers before attempting to remove or replace the trip unit. Because of the exposed location of the trip unit, failure to observe this warning may result in equipment damage or personal injury, including death.

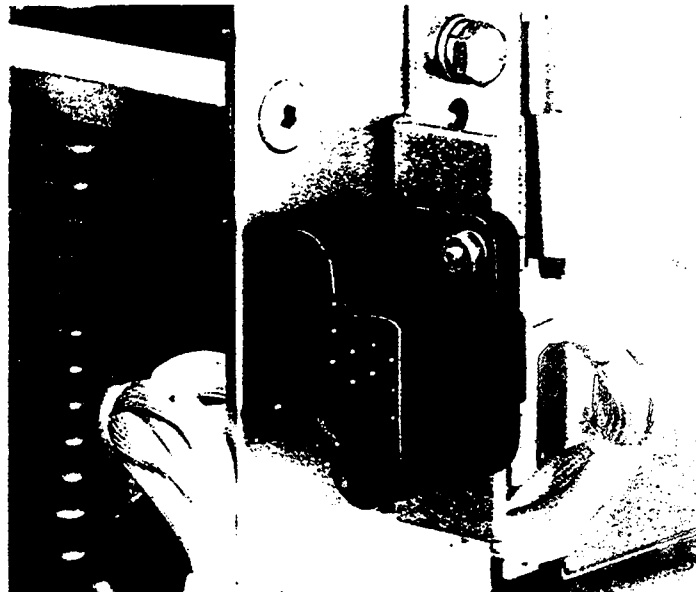

Fig. 114. Programmer secondary connector

	Socket		
	Class No.		
Zone Selective Interlock	5	+	Zone Inputs
	6	-	
	7	+	Zone Outputs
	8	-	
MVT-PM	11	-	Commnet
	12	+	
	9		Spare
	10		VC
	1		VB
	4		VA
	2		24 Ret
	3		+ 24 VDC

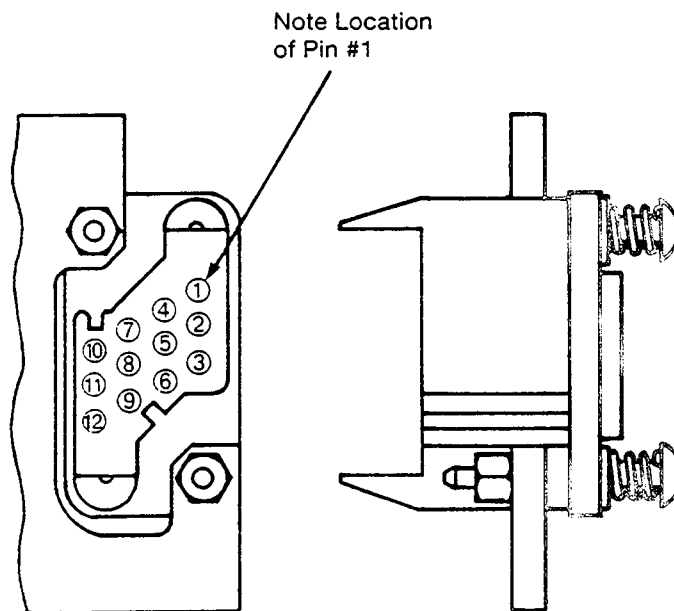

Fig. 115. Programmer secondary connector pin locations for zone selective interlock and MVT-PM

SECTION 12—Microversatrip™ Plus and Microversatrip PM Trip Units

12.5—Phase Current Sensors

The current sensors supply the power and signal input necessary to operate the trip system. Fig. 117 shows the fixed phase sensors available. The sensors have a polarity associated with their windings. The common terminal of the sensor is the right hand terminal. A white wire with a push-on terminal will be connected to this common terminal. All phase sensors must be correctly wired for the programmer summing circuitry to function properly.

The fixed phase sensors are available with an additional winding. This winding is brought out to separate flag terminals. These phase sensors are used when the hi-level instantaneous ('H'-option) is required. Fig. 118 shows an 'H'-option phase sensor. When the 'H'-option phase sensor is installed, there are four leads connected to it. There is no polarity associated with the 'H'-option windings.

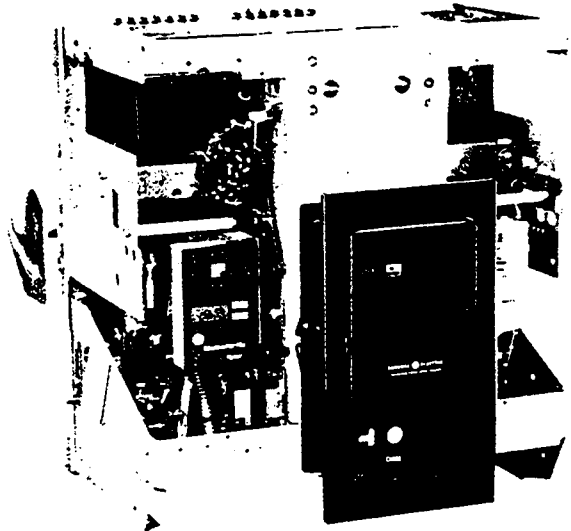

AKR-9D-100

Fig. 116

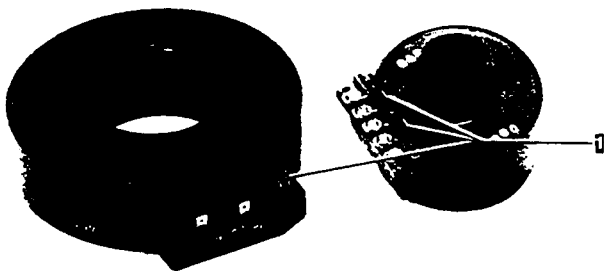

Fig. 117. Phase Sensors

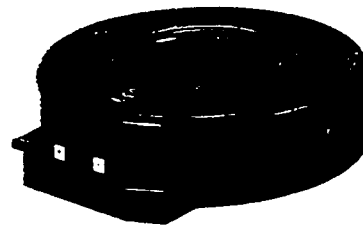

Fig. 118. H-option phase sensor

12.6—Neutral Current Sensors

CAUTION: Neutral current sensors are required for three-phase, four-wire systems. When the trip unit is connected to a three-phase, three-wire system, the neutral sensor terminals are left open. Do not short any neutral current sensor terminals in a three-phase, three-wire system, as this could result in damage to or malfunction of the electrical system.

Fig. 119 shows the neutral sensor. The neutral sensor is required when integral ground fault protection is used on single phase-three wire or three phase-four wire systems. It is inserted into the neutral conductor and therefore is separately mounted in the cable or bus compartment.

The outputs of the phase sensors and neutral sensor are connected to a programmer circuit which sums these values. The total value will remain zero as long as there is no ground current flowing.

The neutral sensor is an electrical duplicate of the phase sensor. Therefore, when phase sensors are changed, the neutral sensor must be correspondingly changed.

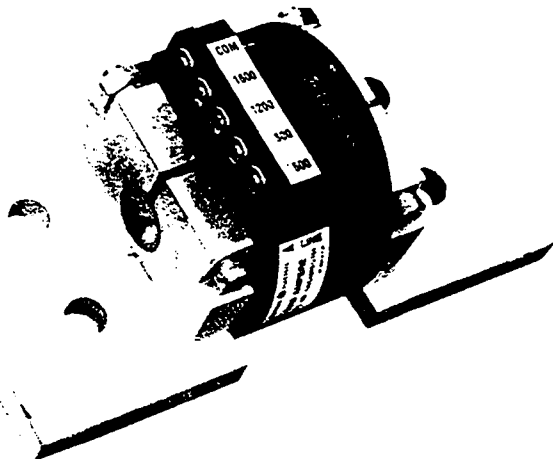

Fig. 119. Typical neutral sensor

12.7—Rating Plug Removal and Replacement

CAUTION: Removal of the rating plug while the breaker is carrying current reduces the breaker's current-carrying capacity to approximately 25% of the current sensor rating.

Interchangeable rating plugs are removed with a Rating Plug Extractor, Cat. No. TRTOOL. (Suitable equivalents are commercially available as "integrated circuit (DIP) extractors.") Grasp the rating plug tabs with the extractor and pull the plug out. Be sure to grab the tabs and not the front cover of the rating plug, or the plug may be damaged.

Rejection features are provided on all rating plugs to prevent application mismatches. Never force a rating plug into place. Refer to Table 20 to find the appropriate rating plugs for each sensor rating and breaker frame.

If a replacement rating plug has a different rating than the plug that was removed, follow the appropriate setup procedure in GEH-5891A to enter the new rating.

Do not attempt to use a rating plug from a Spectra RMS breaker or a MicroVersaTrip™ RMS-9/MVT-4 function trip in a MicroVersaTrip Plus or MicroVersaTrip PM trip unit.

TABLE 20. Rating plug catalog numbers

Cat No.	Sensor Rating, Amps	Plug Rating	Breaker Frames
TR32B1200 TR32B1600 TR32B2400 TR32B3200	3200	1200 1600 2400 3200	AKR75
TR40B1600 TR40B2000 TR40B2500 TR40B3000 TR40B3600 TR40B4000	4000	1600 2000 2500 3000 3600 4000	AKR100

12.8—Trip Unit Functions

MicroVersaTrip Plus and MicroVersaTrip PM trip units have specific standard and optional functions. All trip units share a series of interchangeable rating plugs. The standard functions for both types of trip unit are as follows:

- Protection
 - Long-time protection
 - Instantaneous protection
- Status
 - Trip target
- Metering display
 - Phase current (selectable among phases)

The optional functions available on both types of trip unit are as follows:

- Adjustable protection
 - Switchable instantaneous and ground-fault protection
 - High-range (fixed) instantaneous overcurrent protection
 - Short-time protection, with or without I²T
 - Ground-fault protection, with or without I²T
 - Zone-selective interlock, with ground fault only or with both ground fault and short time

Additional optional functions available only with PM style trip units are as follows. PM style trip units require the presence of external control power.

- Configurations
 - Communication and metering
 - Communication and protective relaying
 - Communication, metering, and protective relaying
- Metering and protective-relaying functions
 - Voltage
 - Energy (kWh/MWh)
 - Real power (kW/MW)
 - Total power (kVA/MVA)
 - Frequency (Hz)
 - Protective relays (undervoltage, overvoltage, voltage unbalance, current unbalance, and power reversal)

SECTION 12—Microversatrip™ Plus and Microversatrip PM Trip Units

12.9—Trouble-Shooting Guide

The following guide is provided for trouble-shooting and isolating common problems. It does not cover every possible condition. Contact the Customer Support at 800-843-3742 if the problem is not resolved by these procedures.

Symptom	Possible Cause	Corrective Action
1. The trip unit display is blank.	Line current is below 20% of S (MicroVersaTrip Plus).	At least 20% of the current sensor rating, S, must be flowing through the breaker to activate the display. If not, power the trip unit with the Test Kit or external battery pack.
	External 24 Vdc is absent (MicroVersaTrip® PM).	Check that the control power supply is present and operational.
2. The trip unit display flashes.	Can occur on Plus style trip units when load current fluctuates near 20% of S.	Power the trip unit with the Test Kit or external battery pack.
3. The trip unit display flashes ERR.	The built-in self test has detected an error.	Replace the trip unit.
4. The trip indication target will not clear.	Trip unit is not in status mode.	Press FUNCTION until STATUS is displayed. Press SELECT and VALUE together to clear the target.
5. Unit does not communicate with the Monitor, POWER LEADER Distribution Software, or FPU.	Commnet wires are shorted or improperly connected.	Locate and repair the short or the incorrect connection.
	FPU version is lower than 2.0	Update FPU to version 2.0 or higher.
	Trip unit address incorrect.	Check that address assigned to trip unit, as in Chapter 2, agrees with address at host.
6. Current readings are incorrect.	Rating plug value was defined incorrectly.	Read the X value from the rating plug nameplate and enter this with the rating plug current set point procedure in Chapter 2. <i>Do not enter the sensor rating, S.</i>
7. Voltage readings are incorrect.	Potential transformer (PT) primary voltage was defined incorrectly.	Read the PT ordinary rating from the PT nameplate and enter this value with the PT primary voltage procedure in Chapter 2.
	PT connection was defined incorrectly.	With the PT connection procedure in Chapter 2, enter VL-N for a wye-connected PT primary or VL-L for a delta-connected PT.
8. kW legend is flashing.	Total power metering.	Indicates that the total power is metered in kVA.
9. Overload target is flashing by itself.	Test Kit-initiated trip indication.	Clear target as indicated above (Symptom 4).

SECTION 13—Type EC Overcurrent Trip Device

Type EC overcurrent trip devices are magnetically operated, using a series coil or single conductor, and an associated magnetic structure to provide tripping force.

There are three basic characteristics: long time delay, short time delay and instantaneous, which can be used in various combinations to suit the application.

AKR breakers with EC trips are for use on DC system voltages. One EC trip device is mounted per breaker pole. This device contains its functional adjustments.

The standard EC trip device for the AKS breaker frame, the type EC-2A, see Fig. 120. An optional trip device for these frames is the type EC-1, see Fig. 121.

The EC trip device for the 4000 and 6000 amp AKR 75/100 frames is the EC-1B shown in Fig. 122.

The trip characteristics for the EC trip devices are listed in Table 21.

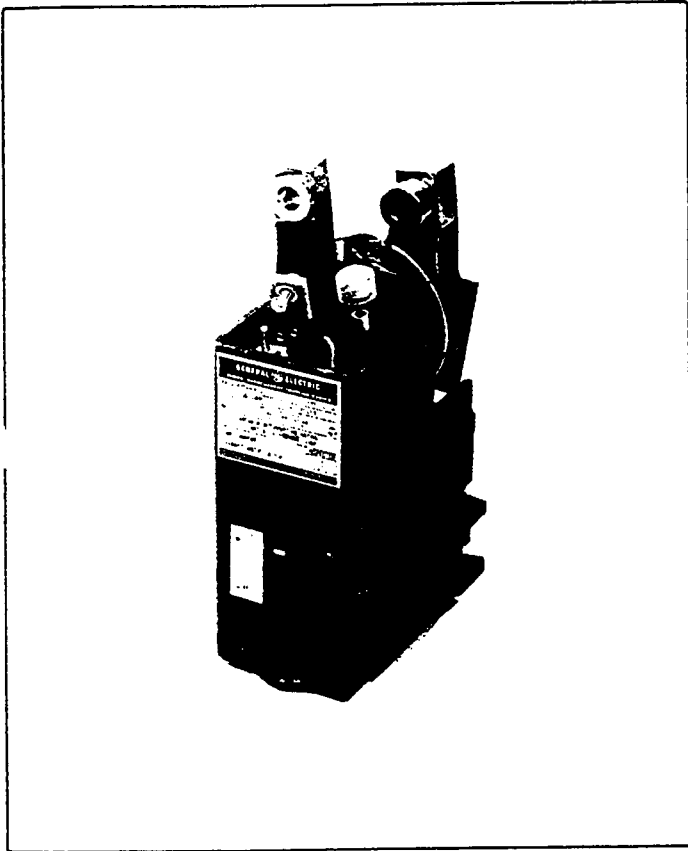

Fig. 120. EC-2A trip device

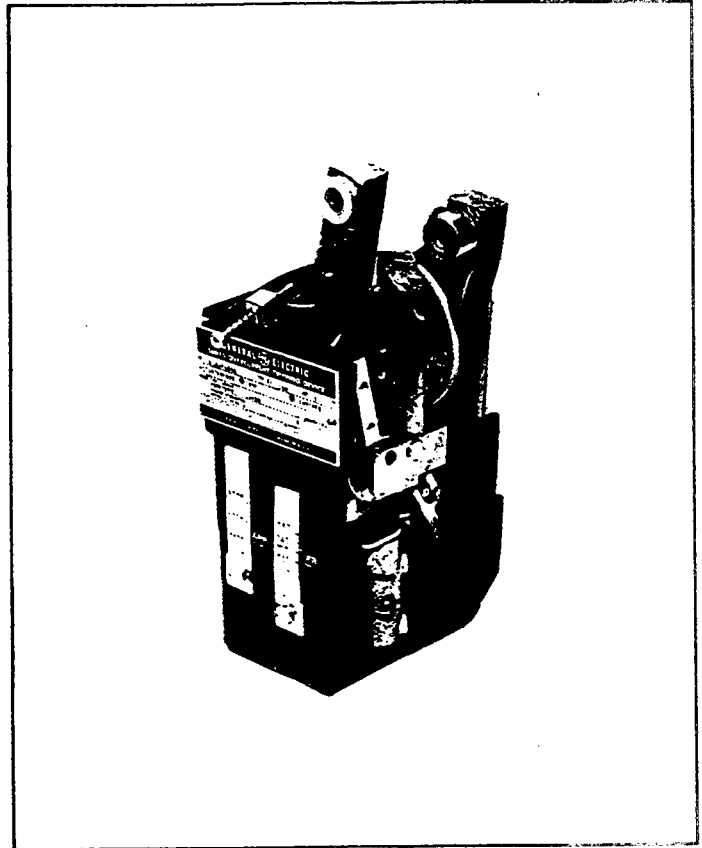

Fig. 121. EC-1 trip device

SECTION 13—Type EC Overcurrent Trip Device

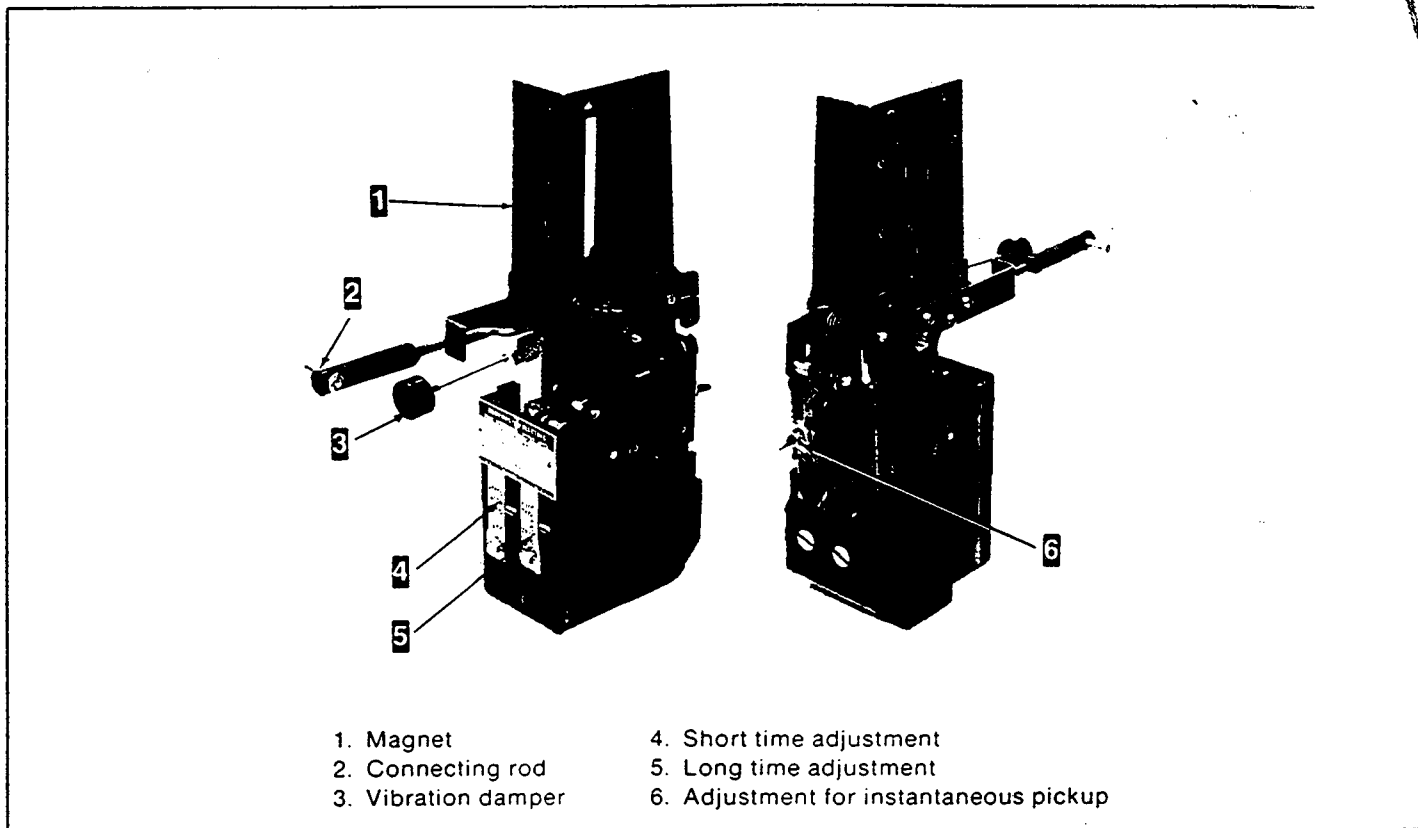

Fig. 122. EC-1B trip device

TABLE 21—EC Device Trip Characteristics

Trip Device	Long Time		Short Time		Instantaneous Pickup
	Pickup ①	Delay ②	Pickup	Delay ③	
EC-2A	80-160% X (± 10%)	(1A) MAX. — adj 15-38 sec or (1B) INTER — adj 7.5-18 sec. or (1C) MIN — adj 3.3-8.2 sec.			4-9X, 6-12X, 9-15X or 80-250% X ④
EC-1	80-160% X (± 10%)	(1A) MAX. — 30 sec. or (1B) INTER — 15 sec. or (1C) MIN — 5 sec	2-5X, 3-7X or 4-10X	(2A) MAX. — .23 sec. or (2B) INTER. — .15 sec or (2C) MIN — .07 sec	High Set up to 15X, Non-Adjustable
EC-1B	80-160% X (± 15%)	(1BB) MAX — 4.5 sec or (1CC) MIN — 2 sec	2-5X, 3-7X or 4-10X	(2AA) MAX — .20 sec. or (2BB) INTER — .13 sec. or (2CC) MIN — .07 sec.	4-9X, 6-12X, 9-15X or 80-250% X ④

1 X = Trip device ampere rating. If trip devices are set above 100% for coordination purposes, such settings do not increase the breaker's continuous current rating.

2 At lower limit of band at 6 times pickup setting

3 At lower limit of band at 2½ times pickup setting

4 Low set instantaneous. Not available in combination with long time delay

13.1—Direct Acting Tripping Device EC-1B

The type EC-1B overcurrent tripping device is a direct-acting device that causes the power circuit breaker with which it is associated to open within a predetermined time range which depends upon the magnitude of the current overload. The EC-1B tripping device can be constructed to supply a variety of different types of time-current characteristics, either alone or in combination. These are long time delay, short time delay, and instantaneous, and they are identified respectively by numbers 1, 2 and 3. Characteristics are further broken down within each of the first two of these general classifications into maximum, intermediate and minimum values of the time delay period. These are coded respectively as AA, BB and CC. Time and current relationships for the various device characteristics are given by the curves listed in Table 18.

TABLE 22—Time-Current Curves

Trip Device	Trip Elements ①	Trip Characteristic (EC Devices only)	Curve
EC-1	LSI	(See Curves)	GES-6000A
EC-1B	LI	1B-3	GES-6003
	LI	1CC-3	GES-6004
	LSI	(See Curves)	GES-6005
EC-2 2A	LI	1A-3	GES-6010
	LI	1B-3	GES-6011
	LI	1C-3	GES-6012

① L = Long Time S = Short Time I = Instantaneous

13.1.1—Long Time Delay Tripping

Referring to Fig. 123, the long time delay is obtained as follows:

The long time delay armature (22) is restrained by the long time delay calibration spring (15). After the magnetic force produced by the overcurrent condition overcomes this restraint, the velocity of the armature movement is governed by the flow of oil through an orifice in the piston of the dashpot (17). The time required to displace the piston is inversely proportional to the force tending to close the magnetic circuit.

13.1.2—Short Time Delay Tripping

Referring to Fig. 101 the short time delay is obtained as follows:

The short time delay armature (1) is restrained by a calibration spring (6). If the force tending to close the armature against the magnet (11) is great enough to overcome the spring force, the speed of movement is governed by the mechanical escapement mechanism consisting of parts (2), (3), (4) and (5).

13.1.3—Instantaneous Tripping—High Set

Referring to Fig. 123 adjustable instantaneous tripping is accomplished by varying the amount of tensile force on the high-set instantaneous spring (21). When a magnetic force greater than the restraining spring force is produced by an over-current condition, the armature (22) is pulled upward against the magnet (24), thus tripping the breaker by the movement of the connecting rod (13) against the trip paddle (14).

The pickup value of the device may have one of the following ranges: 4 to 9, 6 to 12, or 9 to 15 times coil rating. Three calibration marks will appear on the calibration scale (18) and the value of these calibration marks will be indicated by stampings on the scale as follows: (4X-6.5X-9X) or (6X-9X-12X) or (9X-12X-15X), depending on the desired range. To set the device at a particular pickup value, loosen the clamping nut (20) and slide the index pointer on the calibration washer (19) to a position which lines up horizontally with the desired pickup value on the calibration scale (18).

13.1.4—Instantaneous Tripping—Low Set

Low-set instantaneous tripping is adjustable from 80 percent to 250 percent of the continuous current rating of the device. Whenever this is used, it is the only characteristic of the device. Instantaneous tripping used in conjunction with any other characteristic is always high-set.

If the characteristic of the device is low-set, adjustable instantaneous, a link is installed in place of spring (21) and the instantaneous calibration spring is located where spring (15) is shown in Fig. 26. Dashpot (17) is omitted from assembly. See Fig. 101.

13.2—Replacement

The EC-1B device is replaced as follows, referring to Fig. 123:

1. Remove stud (23).
2. Remove mounting clamp.
3. Remove two screws fastening magnet (11) to lower stud.
4. Device is now free of breaker. Reassembly is accomplished by reversing the procedure.

When reassembling the magnet to the lower stud, be sure to replace any spacing washers in the same location in which they were found during disassembly. If this is not done, misalignment and consequent malfunction may result.

SECTION 13—Type EC Overcurrent Trip Device

13.3—Adjustments

Before the EC-1B overcurrent device is calibrated at the factory, the air gaps between magnet (11) and armatures (1 and 22) are set. These gaps are measured at their widest point, between the front edge of the armature and magnet. The gap for the short time delay armature is 17/64 in., and for the long time delay armature is 17/64 in. Both have a plus and minus tolerance of 1/64 in.

The air gap setting is a factory adjustment and is not to be attempted in the field. If any change occurs, the calibration of the device will not be true. If any calibration difficulties are experienced, they may be due to the fact that the air gap setting has been altered by rough handling or shipment damage. If a check of the air gap measurement reveals that the setting is beyond the tolerance, the device should be returned to the factory for recalibration.

The adjustment screw (7) is provided so that the short-time mechanism will pick up the trip link (8) at the same point at which it is picked up by the long-time mechanism. This may be checked before the device is mounted by pulling forward on the connecting link (10) and checking visually to see that trip link (8) contacts both the set pin in the long time linkage and the end of adjustment screw (7).

After the device is mounted on the breaker, a final adjustment that must be made in the length of the

connecting rod (10). This is made by varying the amount of thread engagement between the connecting rod and the insulated coupling which ties onto the trip paddle (14). The approximate distance between the pivot centers on the ends of the connecting rod assembly is six inches. The correct exact distance is that which will just cause tripping of the breaker when the armature is closed to a point 1/32 in. short of contact with the magnet. A step-by-step procedure for making this adjustment follows.

1. Before mounting the trip device, set the center distance between the pivot centers of the connecting rod at six inches.

2. Close the breaker and insert a feeler gage 1/32 in. thick between the armature and magnet. This should be done from the rear of the breaker. The feeler gage should be no wider than 1/2 in. and at least 4 inches long.

3. Close the armature against the gage and magnet.

4. If the breaker does not trip, form paddle 14 to obtain positive trip.

5. Check visually to make sure that the connecting rod does not restrict the engagement of the breaker trip latch when the breaker mechanism resets. It should always be possible to adjust its length to a point where resetting is not interfered with and yet positive tripping by the overcurrent device is achieved.

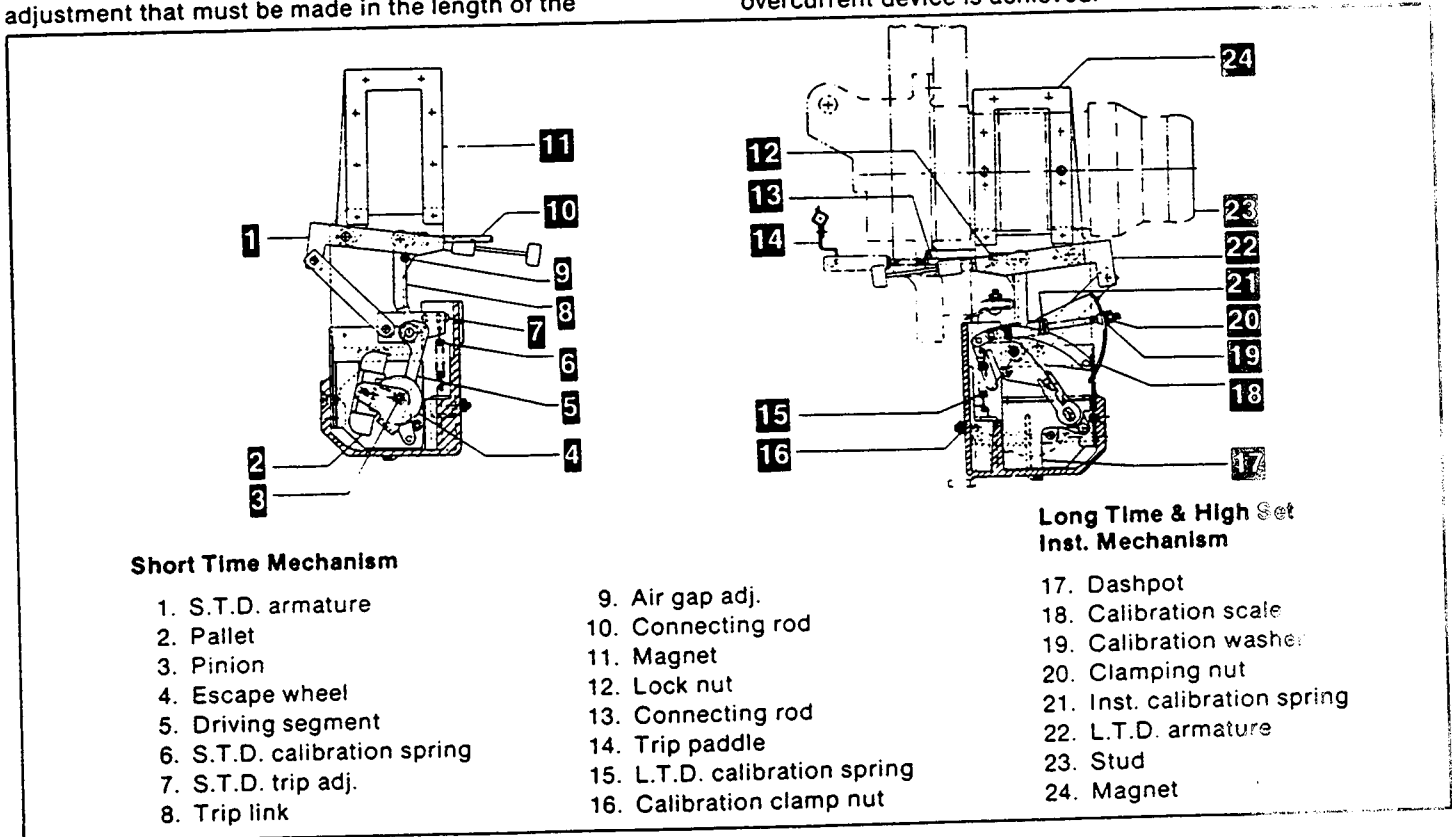

Fig. 123. Direct acting tripping device EC 1B

13.4—Series Overcurrent Tripping Device EC-2A

The Type EC-2A overcurrent tripping device is available in three forms:

1. Dual overcurrent trip, with long-time delay and high-set instantaneous tripping.
2. Low-set instantaneous tripping.
3. High-set instantaneous tripping.

The dual trip has adjustable long-time and instantaneous pick-up settings and adjustable time settings. Both forms of instantaneous trip have adjustable pick-up settings.

Adjustment Note

Before attempting any checks or adjustments on breaker with EC trip devices, the breaker mechanism and trip latch should be checked to assure their proper functioning so that the breaker trip shaft is free of high friction loads. The trip latch of the breaker should also be checked for proper trip latch engagement. See Section 6.3.1.

Refer to Fig. 124 for the discussions given below.

13.4.1—Long Time-Delay and High-Set Instantaneous Tripping

By means of the adjustment knob (3), which can be manipulated by hand, the current pick-up point can be varied from 80 to 160 percent of the series coil rating. The indicator and a calibration plate (2) on the front of the case provide a means of indicating the pick-up point setting in terms of percentage of coil rating. The calibration plate is indexed at percentage settings of 80, 100, 120, 140, 160.

As in the case of the EC-1 over-current trip, the long-time delay tripping feature can be supplied with any one of three time-current characteristics which correspond to the NEMA standards maximum, intermediate and minimum long-time delay operating bands. These are identified as 1A, 1B and 1C characteristics, respectively. Approximate tripping time for each of these, in the same order are 30, 15, and 5 seconds at 600 percent of the pick-up value of current. (See time-current characteristic curves).

The tripping time may be varied within the limits shown on the characteristic curves by turning the time adjustment screw (4). Turning in a clockwise direction increases the tripping time; counterclockwise motion decreases it. The dashpot arm (8) is indexed at four points, MIN-1/3-2/3-MAX, as indicated in Fig. 124. When the index mark on the connecting link (9) lines up with a mark on the dashpot arm, the approximate tripping time as shown by the characteristic curve is indicated. The 1A and 1B characteristic devices are shipped with this setting at the 2/3 mark and the 1C characteristic at the 1/3 mark. Standard characteristic curves are plotted at these settings.

Time values are inversely proportional to the effective length of the dashpot arm. Therefore, the linkage setting that gives the shortest time value is the one at which dimension "A", Fig. 123 is greatest. The time adjustment screw (4) may be turned by inserting a Phillips head screwdriver through the hole in the front of the case. If it is desired to relate the linkage setting to the index marks on the linkage it will be necessary to remove the case. This may be done by removing the two mounting screws, one on each side of the case, which may be taken off without disturbing the trip unit itself.

13.4.2—Instantaneous Low-Set Tripping

The low-set instantaneous pick-up point may be varied by the adjustment knob (3). The calibration in this case usually ranges from 80 percent of 250 percent of the series coil rating, with the calibration plate indexed at values of 80, 100, 150, 200, and 250 percent of the rating.

13.4.3—Instantaneous High-Set Tripping

The high-set instantaneous pick-up value may have one of the following three ranges: (4 to 9), (6 to 12), (9 to 15) times coil rating. The pick-up setting may be varied by turning the instantaneous pick-up adjusting screw (12).

Three calibration marks (15) will appear on the operating arm (14) and the value of these calibration marks will be indicated by stampings on the arm as follows: (4X-6.5X-9X) or (6X-9X-12X) or (9X-12X-15X).

At the factory, the pick-up point has been set at the nameplate value of the instantaneous trip current. (Usually expressed in times the ampere rating of the trip coil). The variation in pick-up setting is accomplished by varying the tensile force on the instantaneous spring (5). Turning the adjustment screw changes the position of the movable nut (11) on the screw. The spring is anchored to this movable nut so that when the position of the nut is changed, there is a corresponding change in the spring load. As the spring is tightened, the pick-up point is increased.

The top edge of the movable nut (11) serves as an index pointer and should be lined up with the center of the desired calibration mark (15) to obtain the proper instantaneous trip setting.

The trip screw (6) on the end of the armature (7) should be set so that it does not contact the trip paddle on the trip shaft until the air gap between armature and pole piece is reduced to 3/32 in. or less, measured at the rivet in the pole piece. Also, the armature must have a minimum of 1/32 in. of travel beyond the point in its motion at which the breaker is tripped.

SECTION 13—Type EC Overcurrent Trip Device

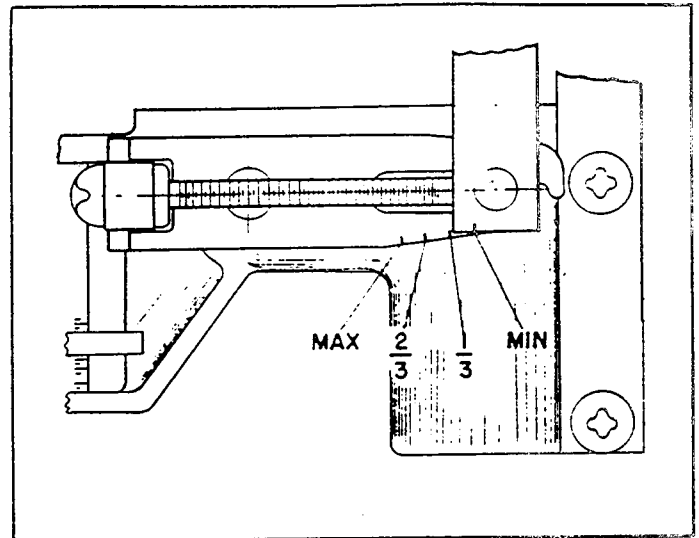

Fig. 125. Time-adjustment indexing

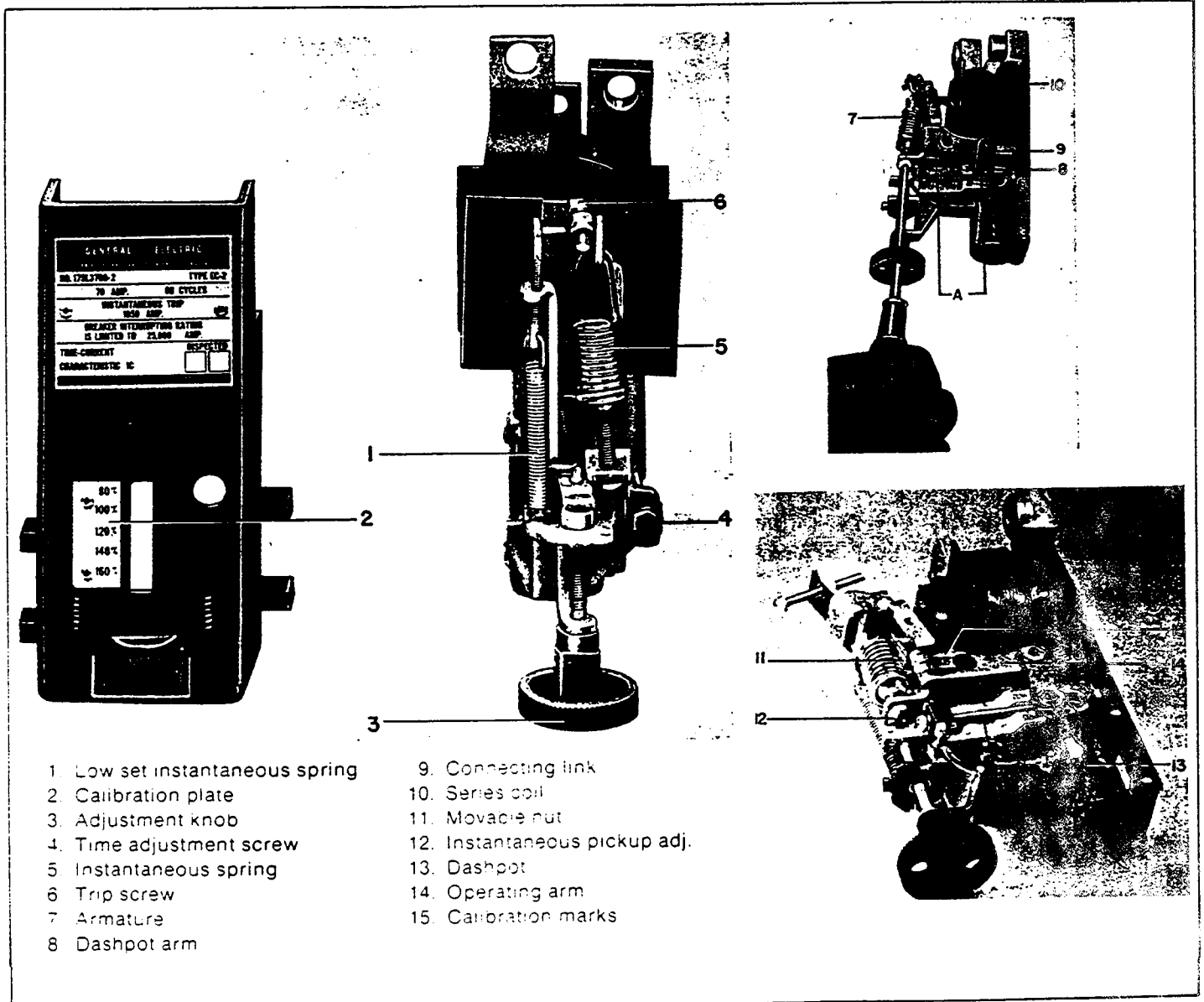

Fig. 124. Overcurrent tripping device—EC-2A

13.5—Series Overcurrent Tripping Device EC-1

Each series overcurrent tripping device is enclosed in a molded case and mounted by screws and a bracket to the lower part of the pole unit base.

Refer to Fig. 126 for the discussions below.

13.5.1—Short Time-Delay Tripping

The armature (7) is restrained by calibrating spring (8). After the magnetic force produced by an overcurrent condition overcomes this restraining force, the armature

movement is further retarded by an escapement mechanism which produces an inverse time delay characteristic. The mechanism is shown on Fig. 126.

13.5.2—Long Time-Delay Tripping

The armature (10) is restrained by the calibration spring (11). After the magnetic force produced by an overcurrent condition overcomes this restraining force, the armature movement is further retarded by the flow of silicone oil in a dashpot, which produces an inverse time delay characteristic. The mechanism is shown on Fig. 126.

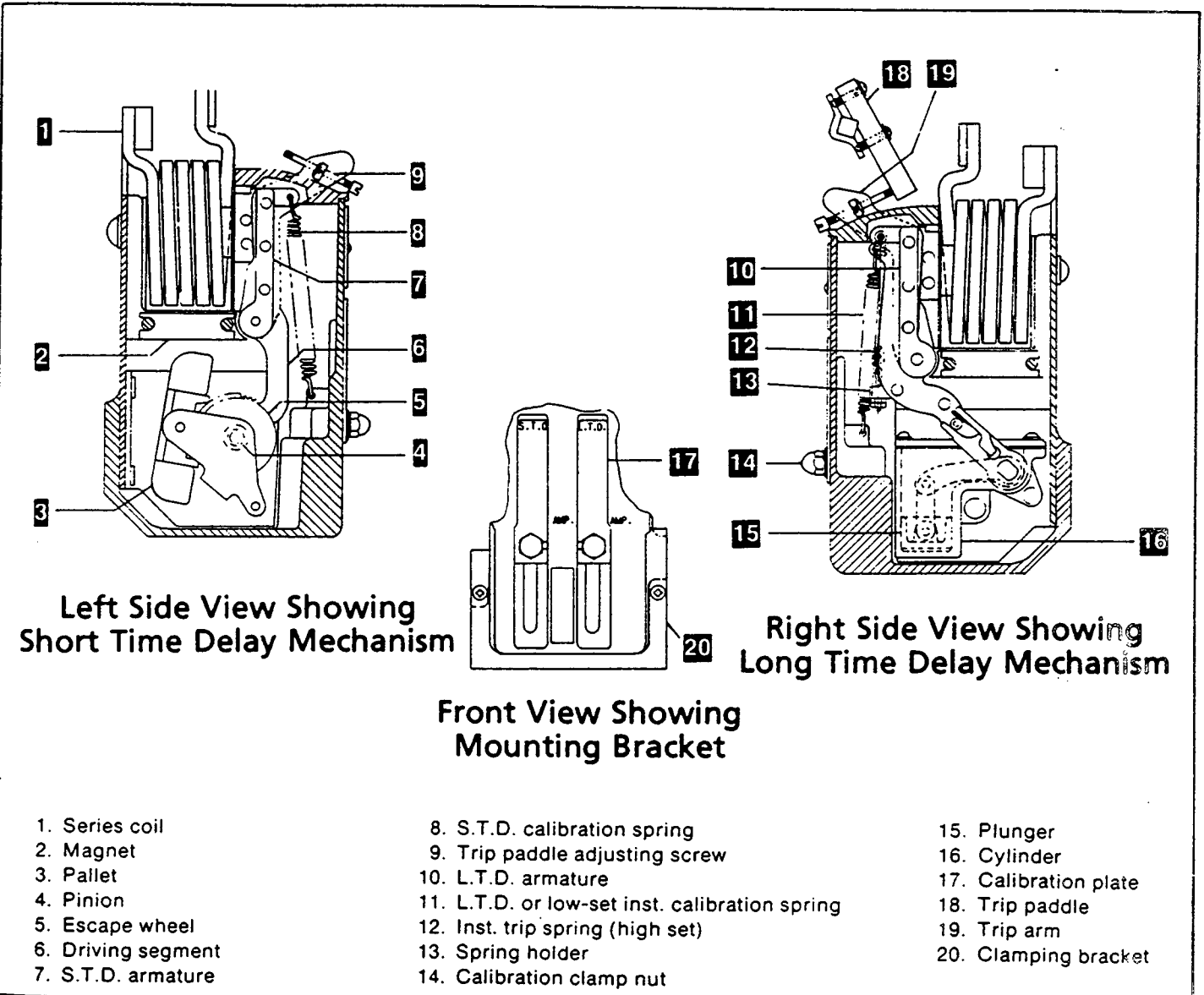

Fig. 126. Series overcurrent tripping device EC-1

SECTION 13—Type EC Overcurrent Trip Device

13.5.3—Instantaneous Tripping

a. Adjustable instantaneous tripping takes place after the magnetic force produced by an overcurrent condition overcomes the restraining force of the calibration spring which can be adjusted by the calibration clamp nut (14).

b. Non-adjustable instantaneous tripping takes place after the magnetic force produced by an overcurrent condition overcomes the restraining force of a non-adjustable spring.

13.5.4—EC-1 Adjustments

Before attempting any checks or adjustments on breaker with EC trip devices, the breaker mechanism and trip latch should be checked to assure their proper functioning so that the breaker trip shaft is free of high friction loads.

EC-1 Devices may have their pick-up settings varied by changing the positions of the sliding calibration plates on the front of each device. The clamping nut holding the plate must be loosened to make the change, and then retightened.

If a new device is installed, the adjusting screw on the tripping arm must be set to give 1/32nd of an inch overtravel in tripping. The method for making this check is demonstrated in Figure 127. The rod shown is used for pushing the armature of device closed. If this is done with the device mounted on a closed breaker, it will simulate the action which occurs when the device reacts to an overload condition.

13.6—Positive Trip Adjustment

Before attempting any checks or adjustments on breaker with EC trip devices, the breaker mechanism and trip latch should be checked to assure their proper functioning so that the breaker trip shaft is free of high friction loads. The trip latch of the breaker should also be checked for proper trip latch engagement. See Section 6.3.1.

In addition to the pick-up settings and time-delay adjustments already described, overcurrent trip devices must be adjusted for positive tripping. This adjustment is made at the factory on new breakers, but must be made in the field when the breaker mechanism or the overcurrent trip devices have been replaced.

Positive tripping is achieved when adjustment screw (9) Figure 126 is in such a position that it will always carry the trip paddle on the trip shaft beyond the point of tripping the mechanism, when the armature closes against the magnet.

In order to make the adjustment, first unscrew trip screws (9), Figure 126, until it will not trip the breaker even though the armature is pushed against the magnet. Then, holding the armature in the closed position, advance the screw until it just trips the breaker. After this point has been reached, advance the screw two additional full turns. This will give an overtravel of 1/16 of an inch and will make sure that activation of the device will always trip the breaker.

Adjustment screw (9), Figure 126 can best be manipulated by an extended 1/4 inch hex socket wrench.

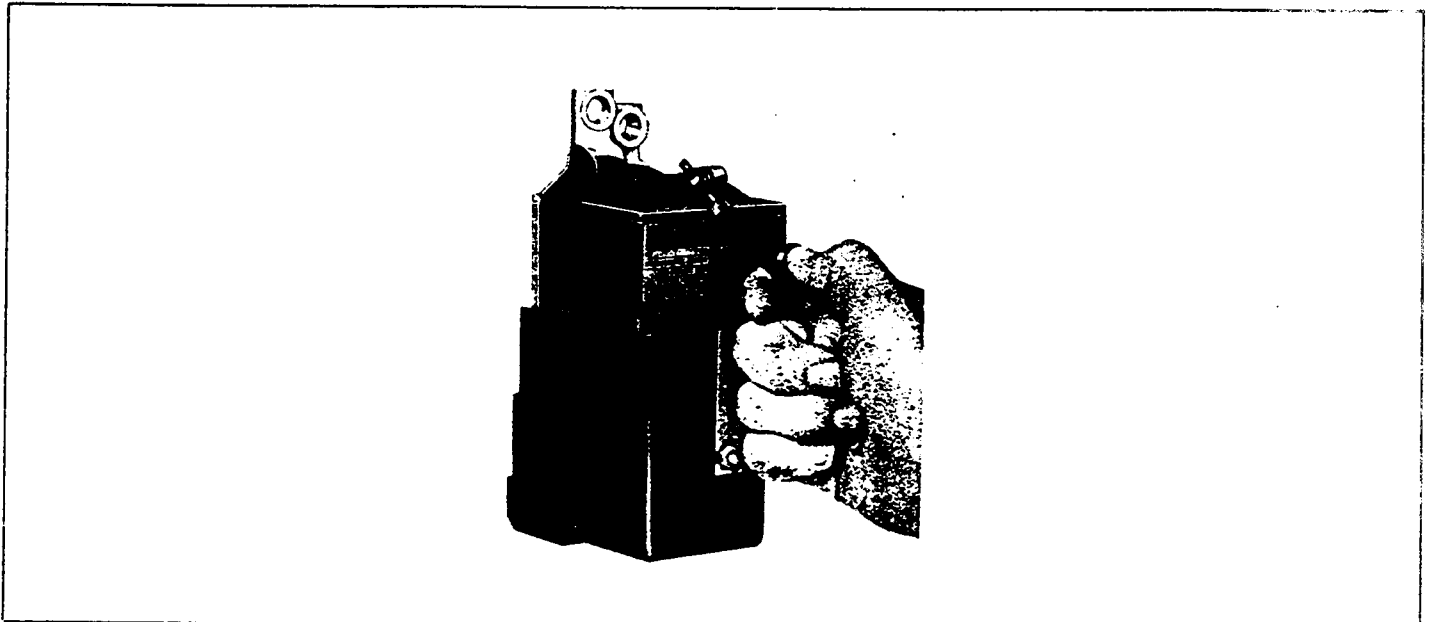

Fig. 127. Checking travel distance of series overcurrent tripping device

13.7—Reverse Current Tripping Device

The device is enclosed in a molded case and is mounted on the right pole base similar to the series overcurrent tripping device.

The reverse current tripping device (see Fig. 128) consists of a series coil (2) with an iron core mounted between two pole pieces (9), also a potential coil (7) connected across a constant source of voltage and mounted around a rotary-type armature (10). Calibration spring (6) determines the armature pick-up when a reversal of current occurs.

As long as the flow of current through the breaker is in the normal direction, the magnetic flux of the series coil and the magnetic flux of the potential coil produce a torque

which tends to rotate the armature counterclockwise. The calibration spring also tends to rotate the armature in the same direction. This torque causes the armature to rest against the stop screw (12) attached to a bearing plate on the right side of the device.

If the current through the series coil (2) is reversed, the armature (10) tends to move in the clockwise direction against the restraint of the calibration spring (6). When the current reversal exceeds the calibration setting, the armature revolves clockwise causing the trip rod (3) to move upward engaging the trip paddle (1), thereby tripping the breaker.

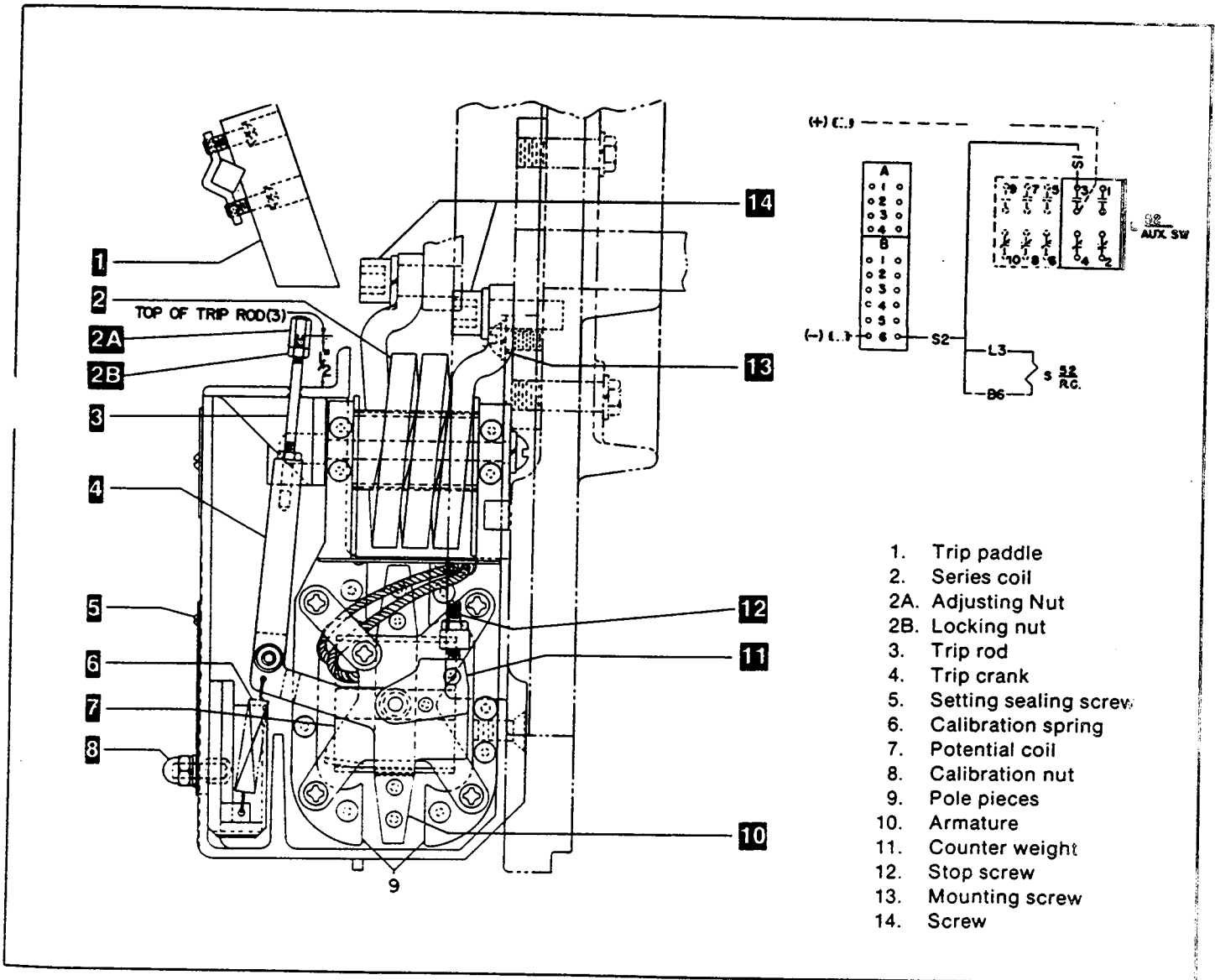

Fig. 128. EC-1 reverse current tripping device

SECTION 14—Electrical Characteristics

TABLE 28—Shunt Trip and Undervoltage Device Operating Currents

Nominal Control Voltage	Frequency Hz	SHUNT TRIP				UNDER VOLTAGE		
		Operating Voltage range		Current (Amps)		Operating Voltage range	Current (Amps)	
				Inrush	Sealed		Inrush	Sealed
		Open	Closed	Open	Closed			
24	DC	14	30	8.3	8.3		Pickup at 85% or less of Nominal Voltage Drop out at 30%-60% of Nominal Control Voltage See Table 30	
48	DC	28	60	4.5	4.5	.38		.38
125	DC	70	140	2.0	2.0	.19		.19
250	DC	140	280	1.0	1.0	.08		.08
70	60	59	132	—	—	.04		.04
120	60	95	127	12.3	10.8	N/A		N/A
120	50	95	127	7.6	6.7	.66		.24
120	25	95	127	4.7	4.1	.75		.25
208	60	175	220	3.2	2.6	.31		.10
208	50	175	220	3.8	3.1	.51		.17
208	25	175	220	2.1	1.9	.30		.10
240	60	190	254	3.9	3.4	.14		.05
240	50	190	254	4.7	4.1	.37		.12
240	40	190	254	5.8	5.1	.34		.11
240	25	190	254	2.1	1.9	N/A		N/A
380	50	315	410	2.9	2.6	.16		.06
480	60	380	508	3.4	3.1	.22		.08
480	50	380	508	7.5	7.3	.23		.08
480	25	380	508	3.5	3.3	.17		.06
575	60	475	625	2.8	2.5	.11		.05
575	50	475	625	5.1	4.7	.16	.06	
575	25	475	625	3.1	3.0	.14	.06	
						.10	.05	

TABLE 29—Coil Resistance—DC Ohms @ 25°

Nominal Control Voltage	Frequency Hz	Anti-Pump Relay "W"	Control Relay "X"	Shunt Trip	Undervoltage
24V	DC	N/A	N/A	3	64
48V	DC	802	12	11	240
125V	DC	5000	119	64	1600
250V	DC	16400	476	260	6700
120V	60	450	54	3.9	25.4
120V	50	450	75	7.15	33
120V	25	1450	75	25.4	146
208V	60	1450	216	25.4	64
208V	50	1450	300	25.4	146
208V	25	3900	300	64	580
240V	60	1450	300	25.4	100
240V	50	1450	300	25.4	146
240V	25	6000	300	64	580
380V	50	N/A	N/A	64	370
480V	60	N/A	N/A	64	370
480V	50	N/A	N/A	32	580
480V	25	N/A	N/A	100	1600
575V	60	N/A	N/A	100	580
575V	50	N/A	N/A	64	918
575V	25	N/A	N/A	146	3200

TABLE 30—Instantaneous Undervoltage Device Settings

COIL RATING	MAXIMUM PICKUP VOLTAGE	DROP OUT RANGE
24 VDC	20	7-14
48 VDC	41	14-29
125 VDC	106	38-75
155 VDC	132	47-93
250 VDC	213	75-150
120 VDC	102	36-72
208 VDC	177	62-125
240 VDC	204	72-144
380 VDC	323	114-228
480 VDC	408	144-288
575 VDC	489	173-345

TABLE 31—Time-Delay Undervoltage Device Settings

DELAY UNIT VOLTAGE	PICK UP RANGE UVR ONLY VDC	UVR INSTALLED MECHANISM RESET		DROP OUT RANGE
		NO PICK UP	PICK UP	
125 VDC	77 - 85	50	90 - 95	MINIMUM POSSIBLE
250 VDC 208/240 VAC	125 - 140	90	160 - 165	

These instructions do not purport to cover all details or variations in equipment nor to provide for every possible contingency to be met in connection with installation operation or maintenance. Should further information be desired or should particular problems arise which are not covered sufficiently for the purchaser's purposes, the matter should be referred to the GE Company.



GE Electrical Distribution & Control

General Electric Company
41 Woodford Ave., Plainville, CT 06062

© 1993 General Electric Company

GEK-64460A

SECTION 13—Type EC Overcurrent Trip Device

13.7.1—Adjustments

The only adjustment to be made on the reverse current device is to make sure that the trip rod has a minimum overtravel of 1/32 in. beyond the point of tripping the breaker. This adjustment should have to be made only when an old device is being replaced by a new one.

The new device will be factory adjusted so that the top end of the trip rod (3) will extend 1/2 in. above the top of the device case, and no additional adjustments of the trip rod should be required. To obtain the proper 1/32 in. overtravel, close the breaker and proceed as follows:

1. Loosen the locking nut. (2B).
2. Manually lift the trip rod and vary the position of the adjusting nut (2A), this establishing the position of the adjusting nut where the breaker is just tripped.

NOTE: Be sure to keep clear of moving breaker parts when tripping the breakers.

3. With this position of the adjusting nut established, advance the adjusting nut upward one and one-half turns.
4. Tighten the locking nut and the minimum 1/32-in. overtravel of the trip rod should be obtained.

13.7.2—Replacement

After removing the wiring for the potential coil the reverse current device can be removed and replaced by following the procedure outlined for replacing the series overcurrent device. See Section 11.9. For wiring, see Fig. 128.

13.8—Switchette Feature

The switchette is operated by the long-time delay function. Its purpose is to provide a set of contacts that will close before an overload occurs. This device will not trip the breaker on overload it will trip on instantaneous only.

The switchette feature is available only in type EC-1 devices.

The switchette is used in one pole and EC-1 trips in the other poles. For the alarm to be effective in indicating the overload before the other poles trip the breaker, the device must have less time delay than the other two poles; this is accomplished by using a lower characteristic on the alarm device than the other poles or setting the alarm devices long time setting at 80%.

13.9—Trip Device Replacement

Overcurrent devices on the AKS50 breakers can be replaced as follows:

- a. Separate frames as described in Section 5.3
- b. Referring to Fig. 126, remove bolts securing the series coil (1) to the lower stud.
- c. Remove the clamping bracket (20).
- d. Before installing the replacement device, check the travel of trip arm as described in Section 11.5.4 and Fig. 127.
- e. Replace new device in reverse order.
- f. Adjust the new device as described in Section 11.5.4

When replacing an EC-1 device with an EC-2 or EC-2A device, it may be necessary to replace the trip paddles on the trip shaft with slightly longer ones. If paddle replacement is required, new paddles are provided with the replacement trip units.

Pickup settings on the cover of the EC-2, EC-2A device are calibrated for the specific device. When replacing covers, replace on associated device.

SECTION 14—Electrical Characteristics

Table 23
Charging and closing operating currents

Table 24
Bell alarm contact-rating

Table 25
Auxiliary switch contact sequence

Table 26
Auxiliary switch contact ratings

Table 27
Charging times

Table 28
Shunt trip and undervoltage device

Table 29
Coil resistance

TABLE 23—Charging and Closing Operating Currents

Nominal Control Voltage	Frequency Hz	Voltage Range	MOTOR		ANTI-PUMP RELAY "W"			CONTROL RELAY "X"			CLOSING SOLENOID			FUSE SELECTION
			Current (Amps)		Min (volts) Pick-up	Rated-Amps		Min (volts) Pick-up	Rated Amps		Min (volts) Pick-up	Rated Amps		
			Inrush	Sustained		Open	Sealed Closed		Inrush	Sealed Closed		Open	Sealed Closed	
48V	DC	38-56	40	10	38	.063	.063	30	4.1	4.1	38	2.7	2.7	20A
125V	DC	100-140	27	5	85	.024	.024	90	1.05	1.05	100	1.3	1.3	20A
250V	DC	200-280	13	3	170	.015	.015	180	.53	.53	200	.68	.68	20A
120V	60	104-127	25	5	95	.090	.052	95	1.0	1.4	98	2.6	.35	20A
120V	50					.090	.052		1.0	.15		2.2	.29	20A
120V	25					.047	.032		6.85	1.27		1.1	.17	20A
208V	60	180-220	15	3.5	175	.050	.029	175	.45	.063	177	1.5	.19	20A
208V	50					.050	.029		.55	.083		1.2	.16	20A
208V	25					.032	.018		3.86	.76		.60	.08	20A
250V	60	208-254	12	3	190	.064	.036	190	.50	.07	196	1.3	.17	20A
250V	50					.064	.036		.50	.08		1.1	.15	20A
250V	25					.035	.023		3.42	.64		.54	.08	20A

① Values are typical and are given only as application information, and not intended to be maximum or minimum values.

Table 24-Bell Alarm Contact Rating

Control Voltage		Bell Alarm Contact Rating (amperes)	
		Inrush	Continuous
Dc	125	2.5	2.5
	250	0.9	0.9
60 Hz. Ac	120	30	10
	240	15	5
	480	7	3

Table 26-Auxiliary Switch Contact Rating

Control Voltage		Auxiliary Switch Interrupting Ratings (Amperes)①	
		Non-Inductive	Inductive
Dc	48	25	—
	125	11	6.3
	250	2	1.8
Ac	115	75	50
	240	50	25
	480	25	12

① Limited to 20A continuous rating of switch on all breakers and to 5A continuous rating of #16 wire on drawout breakers.

Table 25-Auxiliary Switch Contact Sequence

CB Main Contacts	Auxiliary Switch Position	
	"a" Contact	"b" Contact
Open or Tripped	Open	Closed
Closed	Closed	Open

Table 27 Charging Times

Nominal Voltage	Time (sec.) ①
48VDC	2.0
125VDC 250VDC	1.7
120VAC	1.5
208VAC	1.7
240VAC	1.3

① Closing spring charging times are typical values. The maximum permitted is 5 seconds.