

15
GENERAL
ELECTRIC

CANADIAN GENERAL ELECTRIC

1. PGEI-1403 INSTRUCTIONS FOR TYPES
AK-2/3/2A/3A-50/50S/75/75S/100/100S,
AKT-2/3-50/50S, AKU-2/3/2A/3A-50/50S AND
AKF-2C/2D/2E



LOW-VOLTAGE POWER CIRCUIT BREAKERS

TYPES

AK-2/3/2A/3A-50/50S
AK-2/3/2A/3A-75/75S
AK-2/3/2A/3A-100/100S
AKT-2/3-50/50S
AKU-2/3/2A/3A-50/50S
AKF-2C/2D/2E

TABLE OF CONTENTS

TITLE	PAGE
INTRODUCTION	1
OPERATION	1
MANUAL CLOSING	1
MANUAL MAINTENANCE CLOSING OF ELECTRICAL BREAKERS	1
ELECTRICAL CLOSING (FIG. 1)	1
QUICK CLOSE FOR ELECTRICAL BREAKERS (FIG. 1A)	2
ELECTRICAL TRIPPING	3
MAINTENANCE	3
INSERTING SAFETY PIN AK-50, -75 AND -100 (FIG. 3)	3
INSPECTION	5
LUBRICATION	5
SEPARATION OF FRONT AND REAR FRAMES	5
BASIC BREAKER COMPONENTS	6
ARC QUENCHERS (FIG. 4 AND 5)	6
Replacement - AK Breakers	6
Replacement - AKF Breakers	6
Disassembly - AK And AKF Center Pole (Fig. 4)	6
Disassembly - AKF Outer Poles (Fig. 5)	7
POLE UNIT ASSEMBLY (FIG. 6)	7
Measuring Contact Wipe (Fig. 6)	8
Measuring Contact Pressure (Fig. 6)	8
Adjusting Contact Wipe and Pressure (Fig. 6)	8
Contact Sequence (Fig. 6)	9
Contact Gap (Fig. 6)	10
Replacement of Contacts (Fig. 6)	10
OPERATING MECHANISMS	12
Electrically Operated AK-50, -75 and -100	12
QUICK CLOSE BREAKER ADJUSTMENTS	14
STORED ENERGY MANUAL MECHANISM	16
Closing The Breaker (Fig. 15)	16
Inserting The Safety Pin (Fig. 15)	16
Replacement (Fig. 15)	16
Adjustments (Fig. 15)	18
AKF MECHANISM (FIG. 17)	18
Contact Adjustments	18
Contact Replacement	20
AUXILIARY SWITCH	20
AK Breakers (Fig. 18)	20
AKF Breakers (Fig. 20)	21
ELECTRICAL CLOSING DEVICES AND CONTROLS	22
CLOSING SWITCH	22
CUT-OFF SWITCHES (FIG. 21)	22
CONTROL RELAY	22
PROTECTIVE DEVICES	22
STATIC TIME DELAY UNDER-VOLTAGE TRIPPING DEVICE (FIG. 22)	22
Replacement (Refer to Fig. 22)	23

TABLE OF CONTENTS (Cont'd)

TITLE	PAGE
INSTANTANEOUS UNDER-VOLTAGE TRIPPING DEVICE	24
UNDERVOLTAGE LOCKOUT DEVICE (FIG. 25)	24
DIRECT ACTING TRIPPING DEVICE EC-1B (FIG. 26)	
(USED ON AK-2-75 AND AK-2-100)	24
Short Time-Delay Tripping (Fig. 26)	25
Long Time-Delay Tripping (Fig. 26)	25
Instantaneous Tripping (Fig. 26)	25
Replacement (Fig. 26)	26
Adjustments (Fig. 26)	26
SERIES OVERCURRENT TRIPPING DEVICE EC-1 (FIG. 27)	28
Short Time-Delay Tripping (Fig. 27)	28
Long Time-Delay Tripping (Fig. 27)	28
Instantaneous Tripping (Fig. 27)	28
Adjustments (Fig. 27)	28
Replacement (Fig. 27)	28
SERIES OVERCURRENT TRIPPING DEVICE EC-2, EC-2A, AK-50	29
Long Time-Delay And High-Set Instantaneous Tripping (Fig. 29)	30
Instantaneous Low-Set Tripping (Fig. 29)	30
Instantaneous High-Set Tripping (Fig. 29)	30
REVERSE CURRENT TRIPPING DEVICE AK-50 ONLY (FIG. 31)	31
Adjustments (Fig. 31)	31
Replacement (Fig. 31)	31
POWER SENSOR TRIP	31
General Description	31
Maintenance	33
False Tripping Caused By Faulty Ground Fault Detection	34
Testing Magnetic Coils	34
Replacement of Power Sensor Components	36
SELECTIVE TRIPPING	41
 BREAKER ACCESSORIES	 41
PRIMARY DISCONNECTS AK-50 ONLY	41
Replacement	41
SECONDARY DISCONNECTS	41
Replacement	41
DRAWOUT MECHANISM (FIG. 43)	42
Adjustments (Fig. 43)	42
SHUNT-TRIPPING DEVICE (FIG. 45)	42
Adjustments	43
Replacement of Coil (Fig. 45)	43
BELL ALARM AND LOCKOUT DEVICE (FIG. 46)	43
Adjustments	43
OPEN FUSE LOCKOUT DEVICE (FIG. 47)	44
Operation	45
Adjustments	45
Replacement	45
 MISCELLANEOUS TOOLS	 45
 RENEWAL PARTS	 46

LOW-VOLTAGE POWER CIRCUIT BREAKERS

INTRODUCTION

The instructions contained herein are intended to aid in the maintenance and repair of basic breakers and accessories for AK-50-75-100 Low Voltage Power Circuit Breakers.

The basic AK-50, AK-75 and AK-100 breaker designs have been expanded to include special designs for specific applications. These design extensions have caused variations in the nomenclature including the following:

AK-2-50, AK-2-75 or AK-2-100 - Basic standard design of breaker for stationary mounting or for drawout use in AKD type equipment.

AK-2A-50, AK-2A-75, AK-2A-100 - The A indicates it has mounting features for AKD-5 type equipment.

AK-2-50S, AK-2-75S, AK-2-100S - The S indicates breaker is equipped with a quick-close mechanism which provides closing times of approximately 5 cycles (.08 seconds).

AKU-2-50 - The U indicates an internal fuse breaker combination.

AKF-2C, AKF-2D, AKF-2E - Are field switches for use in controlling shunt fields of synchronous motors and generators.

AK-2-50H - The H indicates the interrupting rating has been increased to the 75,000 amp. class.

AK-2-50C, AK-2-75C - The C indicates the interrupting rating has been increased to the 100,000 amp. class.

AKT-2-50 - The T indicates increased continuous rating of 2000 amps.

AK-3-50, AK-3-75, AK-3-100 - The 3 indicates the breaker is equipped with the Power Sensor Overcurrent Trip Device.

AK-2-50X - The X indicates the breaker has very special features or it includes two or more of the design extensions previously described.

When contacting the factory, it is important to furnish the complete nameplate information.

OPERATION

MANUAL CLOSING

For a description of manual closing, refer to section AK-50-75 AND-100 STORED ENERGY MANUAL MECHANISM.

MANUAL MAINTENANCE CLOSING OF ELECTRICAL BREAKERS

An electrical breaker may be closed manually by means of the maintenance handle furnished with the breaker.

To observe the operation of the breaker without power, with the breaker open and springs discharged, proceed as follows:

1. Charge the closing spring with the maintenance handle (1, Fig. 3) until the indicator reads 'charged'.

2. Continue to operate the maintenance handle until the breaker closes.
3. Open the breaker by pushing the trip button (4, Fig. 2).

ELECTRICAL CLOSING (FIG. 1)

The electrical control system is comprised of an X relay, two double contact mechanically operated switches (F and G), a push button closing switch and any means for remote closing which the user may incorporate into the system. When voltage is first applied to the breaker, (before any closing signal is given) the motor is energized through two of the X relay contacts and the two G switch contacts. The motor then compresses the closing springs to the 'pre-charged' position at which point the mechanically operated F and G switches are operated. This

opens the G contacts, stopping the motor, and closes the F contacts, which readies the system for the final closing of the breaker. When the push button or remote switch signals for a closing operation, the X relay coil is energized, operating the X contacts. This seals in the X relay and energizes the motor once again and the closing operation takes place.

QUICK CLOSE FOR ELECTRICAL BREAKERS (FIG. 1A)

Functionally, the quick close mechanism differs from the standard electrical mechanism in that the pre-

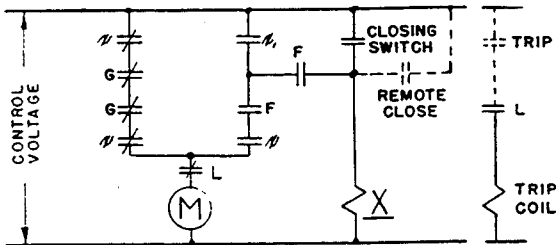

- LEGEND**
- (M) = CLOSING MOTOR
 - X = RELAY COIL
 - = RELAY CONTACT
 - FBG = MECHANICALLY OPERATED SWITCHES
 - ⊥ = NORMALLY OPEN SWITCH CONTACTS
 - ⊢ = NORMALLY CLOSED SWITCH CONTACTS
 - L = AUXILIARY SWITCH CONTACT

SIMPLIFIED ELEMENTARY DIAGRAM
INTERNAL WIRING AK-50, 75, AND 100

Figure 1

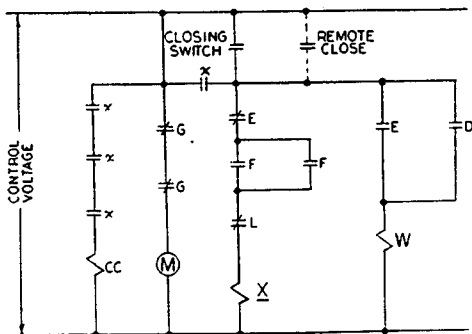

- LEGEND**
- CC - CLOSING RELAY COIL
 - D - CLOSING RELAY CONTACTS
 - E - ANTI-PUMP RELAY CONTACTS
 - F & G - MECHANICALLY OPERATED SWITCHES
 - L - AUXILIARY SWITCH CONTACTS
 - (M) - CLOSING MOTOR
 - W - ANTI-PUMP RELAY COIL
 - X - CONTROL RELAY CONTACTS
 - X - CONTROL RELAY COIL
 - ⊥ - NORMALLY OPEN SWITCH CONTACTS
 - ⊢ - NORMALLY CLOSED SWITCH CONTACTS

SIMPLIFIED ELEMENTARY DIAGRAM
INTERNAL WIRING QUICK CLOSE BREAKER

Figure 1A

charge operation is extended to completely charge the closing springs. At the end of the charging operation, which takes approximately 5 seconds, a latch plate engages the prop roller to prevent the closing springs from discharging.

With the closing springs fully charged the breaker is ready for a closing operation upon release of the prop roller. This may be accomplished either manually, by depressing the closing lever on the breaker, or electrically by closing the remote closing switch. Upon the release of the prop roller the closing springs discharge and close the breaker in the same manner as on the standard electrical breaker.

With control voltage applied, the motor is energized through the G switch contacts, and charges the closing springs. When the springs reach the fully charged position, the mechanically operated switches operate, reversing their contacts. Upon operation of these switches the motor is stopped by the opening of the G switch. The closing of the F switch prepares the breaker for a closing operation.

A closing signal now given energizes the control relay X whose contacts close and complete the circuit through the closing relay coil. With the closing relay coil energized the breaker closes as described above. At the same time the closing relay contact closes to energize the anti-pump relay

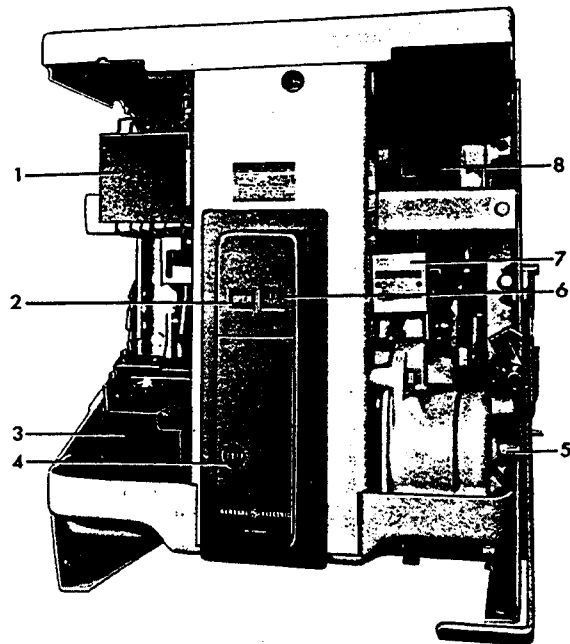

1. Auxiliary Switch
2. Position Indicator
3. Relay
4. Manual Trip Button
5. Shaft for Manual Maintenance Closing Handle
6. Spring Charged-Discharged Indicator
7. Motor Cut-Off Switches
8. Arc Quenchers

Figure 2 Front View of AK-2-50 Breaker

causing its contacts to reverse providing the anti-pump feature.

When the breaker closes, the mechanical operated G switches close to energize the motor again and the F switches open and de-energize the control relay from being energized until the breaker is tripped open. With the G switches closed, the motor charges the closing springs ready for the next closing operation.

ELECTRICAL TRIPPING

The breaker may be tripped electrically by any

of the electrical tripping devices described in these instructions. The breaker may also be tripped by the automatic overcurrent or reverse current tripping devices, if so equipped. All these devices trip the breaker in a similar manner, i.e. the device trip arm moves against the trip paddles fastened on the trip shaft, thus rotating the trip shaft and displacing the trip latch.

The most commonly used tripping device is the shunt trip device connected in the control circuit as shown in Fig. 1. When a tripping signal is given, the shunt trip coil is energized through a normally-open auxiliary switch 'a' contact, thus tripping the breaker.

MAINTENANCE

WARNING

BEFORE INSPECTION OR ANY MAINTENANCE WORK IS DONE BE SURE THAT THE BREAKER IS IN THE OPEN POSITION. ALL ELECTRICAL POWER, BOTH PRIMARY AND CONTROL SOURCES, SHOULD ALSO BE DISCONNECTED.

WARNING

ON BREAKERS EMPLOYING STORED-ENERGY CLOSING MECHANISMS, CARE MUST BE TAKEN WHEN THE CIRCUIT BREAKER IS BEING INSTALLED AND WHEN ANY INSPECTION OR MAINTENANCE WORK IS BEING DONE SO THAT THE BREAKER IS IN THE OPEN POSITION AND THE CLOSING SPRINGS ARE BEING RESTRAINED BY THE SAFETY PIN. THE PROCEDURE FOR INSERTING THE SAFETY PIN IS GIVEN BELOW.

INSERTING SAFETY PIN AK-50, -75 AND -100 (FIG. 3)

The closing spring should be charged with the maintenance handle (1) so that the safety pin (3) can be placed in the hole of the push rod (2). Continue to operate the maintenance handle, closing the breaker. This is done so that the safety pin takes the spring force.

To install the safety pin of the manual stored-energy mechanism refer to the section entitled STORED-ENERGY MANUAL MECHANISM on page 17 of these instructions.

With the safety pin restraining the closing spring force, the contacts will close slowly when the breaker is manually operated allowing the operation of the mechanism and the contact alignment to be visually observed.

Following the inspection period, the closing springs must be recharged, the safety pin removed from the

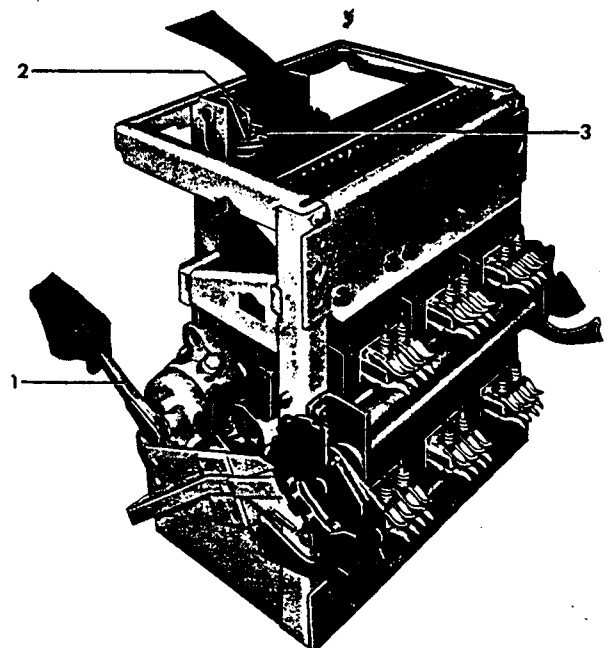

1. Manual Maintenance Handle
2. Push Rod
3. Safety Pin

Figure 3 View Showing Operation of AK-2-50 Breaker With Manual Maintenance Handle and Installation of Safety Pin

TROUBLE SHOOTING

TROUBLE	CAUSE	REMEDY
Overheating	<p>Contacts not aligned.</p> <p>Contacts dirty, greasy or coated with dark film.</p> <p>Contacts badly burned or pitted.</p> <p>Current-carrying surfaces dirty.</p> <p>Corrosive atmosphere.</p> <p>Insufficient bus or cable capacity.</p> <p>Bolts and nuts at terminal connections not tight.</p> <p>Current in excess of breaker rating.</p> <p>Excessive ambient temperature.</p> <p>Inductive heating.</p>	<p>Adjust contacts.</p> <p>Clean contacts.</p> <p>Replace contacts.</p> <p>Clean surfaces of current-carrying parts.</p> <p>Relocate or provide adequate enclosure.</p> <p>Increase capacity of bus or cable.</p> <p>Tighten, but do not exceed, elastic limit of bolts or fittings.</p> <p>Check breaker application or modify circuit by decreasing load.</p> <p>Provide adequate ventilation.</p> <p>Correct bus or cable arrangement.</p>
Failure to Trip AK-2 Breakers	<p>Travel of tripping device does not provide positive release of tripping latch.</p> <p>Worn or damaged trip unit parts.</p> <p>Binds in overcurrent trip device.</p>	<p>Re-adjust or replace tripping device.</p> <p>Replace trip unit.</p> <p>Replace overcurrent trip device.</p>
Failure to Trip AK-3 Breakers	<p>Loose or Disconnected Power Sensor Disconnect Plugs.</p> <p>Loose or Broken Power Sensor Coil Tap Connections.</p>	<p>Tighten or Reconnect Disconnect Plugs.</p> <p>Tighten or Reconnect Tap Connections.</p>
False Tripping AK-2 Breakers	<p>Overcurrent pick up too low.</p> <p>Overcurrent time setting too short.</p> <p>Bind in overcurrent trip device.</p>	<p>Check application of overcurrent trip device.</p> <p>Check application of overcurrent trip device.</p> <p>Replace overcurrent trip device.</p>
False Tripping AK-3 Breakers	<p>Captive Thumb Screw on Power Sensor Loose Fail-Safe Circuitry Reverts Characteristic to Minimum Setting and Maximum Time Delay.</p> <p>Tap Setting Dial on Power Supply Incorrectly Set.</p> <p>External Ground Sensor Coil Improperly Connected.</p>	<p>Tighten Thumb Screw on Desired Setting.</p> <p>Set Dial to Correspond with Power Sensor Coil Tap.</p> <p>Refer to Fig. 40 Page 38 for Polarity and Connections. Check Continuity of Shield and Conductors Connecting the External Ground Sensor Coil</p>
Failure to Close and Latch	<p>Binding in attachments preventing resetting of latch.</p> <p>Latch out of adjustment.</p> <p>Latch return spring too weak or broken.</p> <p>Hardened or gummy lubricant.</p> <p>Safety pin left in push rod..</p> <p>Motor burned out.</p> <p>Faulty control circuit component.</p>	<p>Re-align and adjust attachments.</p> <p>Adjust latch.</p> <p>Replace spring.</p> <p>Clean bearing and latch surfaces.</p> <p>Remove safety pin.</p> <p>Replace motor.</p> <p>Replace or adjust faulty device.</p>
Burned Main Contacts	<p>Improper contact sequence (main contacts not sufficiently parted when arcing contacts part).</p> <p>Short-circuit current level above interrupting rating of breaker.</p> <p>Loss of contact wipe or pressure.</p>	<p>Increase arcing contact wipe. Adjust contact sequence by raising or lowering main movable contact pivot block.</p> <p>Requires system study and possible replacement with breaker having adequate interrupting capacity.</p> <p>Replace stationary contact springs and dress up or replace contacts.</p>

push rod, and the pin placed in the retaining spring clip adjacent to the push rod.

INSPECTION

Periodic inspection of the circuit breaker is recommended at least once a year. More frequent inspections are recommended if severe load conditions, dust, moisture or other unfavorable conditions exist. A complete inspection of the breaker, including contacts and arc quenchers, should always be made after the breaker has interrupted a short-circuit.

At regular inspection periods the breaker should be operated manually (stored energy mechanisms with the safety pin restraining the closing spring force) to observe the contact alignment and to make sure all mechanism parts move freely without binding or excessive friction.

If the breaker remains open or closed for a period of six months or more, it is recommended that arrangements be made to open and close it several times in succession, preferably under load.

If overheating, not caused by overcurrent, is observed, a complete inspection of the breaker should be made including connections and contacts.

At all times it is important not to permit pencil lines, paint, oil or other foreign materials to remain on the insulating surfaces of the breaker as they may cause low resistance between points of different potential and result in eventual electrical breakdown.

The breaker should be operated several times at rated voltage to assure that the control circuits are properly connected and that all electrical attachments are functioning properly.

A complete contact inspection, including contact wipe and pressure, should be made at regular inspection periods and always after a known short circuit current has been interrupted, to determine whether the contacts are worn or pitted in which case they should be dressed or replaced. It is necessary to remove the arc quenchers to properly inspect the contacts. Arcing contacts and arc quencher barriers should be replaced when they are eroded to half their original thickness.

LUBRICATION

In general, the circuit breaker requires moderate lubrication. Mechanical bearing points and sliding surfaces should be lubricated at the regular inspection periods with a thin film of G-E Lubricant

D50H15. Sliding silver plated contact surfaces should be lubricated with G-E Lubricant D50H47. Harder grease and dirt should be removed from latch bearing surfaces by using kerosene. ALL EXCESS LUBRICANT SHOULD BE REMOVED TO AVOID ANY ACCUMULATION OF DIRT OR DUST.

The use of cotton waste to wipe bearing surfaces should be avoided, as the cotton ravelings may become entangled under the bearing surfaces and destroy the surface of the bearing.

On drawout breakers, the contact surface of the disconnect studs should be greased with G-E Grease Specification D50H47.

SEPARATION OF FRONT AND REAR FRAMES

To repair or replace contacts, operating mechanism, or the overcurrent devices, the front frame must be separated from the back frame. To separate the two frames proceed as follows:

1. The breaker contacts must be open with the safety pin in place. (See MAINTENANCE).
2. Remove the two opening springs (on lower part of the breaker) from the outside pole units.
3. Remove the clevis pin (14, Fig. 6) (13, Fig. 13) from the center pole unit.
4. Remove the six nuts from the back frame using a socket wrench with an extension. These include the two nuts at the top of the frame.
5. Remove the auxiliary switch operating rod (5, Fig. 20).
6. Check along the trip shaft for a mechanical interference or connection between the overcurrent trip device and the trip paddles. Remove mechanical connection if present, or if interference exists, use extreme care when removing or re-assembling front and back frames to avoid mechanical breakage of trip devices. In re-assembling the front and rear frames, the two frames should be positioned vertically so that the trip shaft is horizontally aligned.

NOTE

It is recommended that the breaker be fastened to a suitable mounting base with the front frame supported by a sling or hook as the bolts are being installed.

BASIC BREAKER COMPONENTS

ARC QUENCHERS (FIG. 4 AND 5)

The arc quenchers should be inspected at the regular inspection period. If the barriers are cracked or eroded to one-half their original thickness, they should be replaced.

REPLACEMENT-AK BREAKERS

1. Be sure the breaker is open.
2. Remove the channel-shaped retaining bar by removing two screws and two nuts.
3. Lift the quenchers clear of the movable arcing contacts.
4. During replacement be careful not to overtighten the screws which secure the channel-shaped retaining bar. Overtightening the screws will bow the bar and leave the center arc quencher loose.

REPLACEMENT-AKF BREAKERS

The center-pole arc quencher of these breakers

is similar to the arc quenchers of the standard breakers and is replaced in a similar manner, except that the breaker must be closed. With the breaker closed the center-pole contacts are open and the arc quencher can be removed.

Replace the outer-pole arc quenchers of the Type AKF breaker as follows:

1. Be sure the breaker is open.
2. Remove the two channel-shaped retaining bars which bear against the front of the arc quenchers by removing four screws, two on each side.
3. Lift the arc quenchers clear of the movable arcing contacts.
4. Replace arc quenchers and insert the four screws holding the retaining bars in position.

DISASSEMBLY-AK AND AKF CENTER POLE (Fig. 4)

The following instructions apply to both the Type AK and AKF breaker center poles.

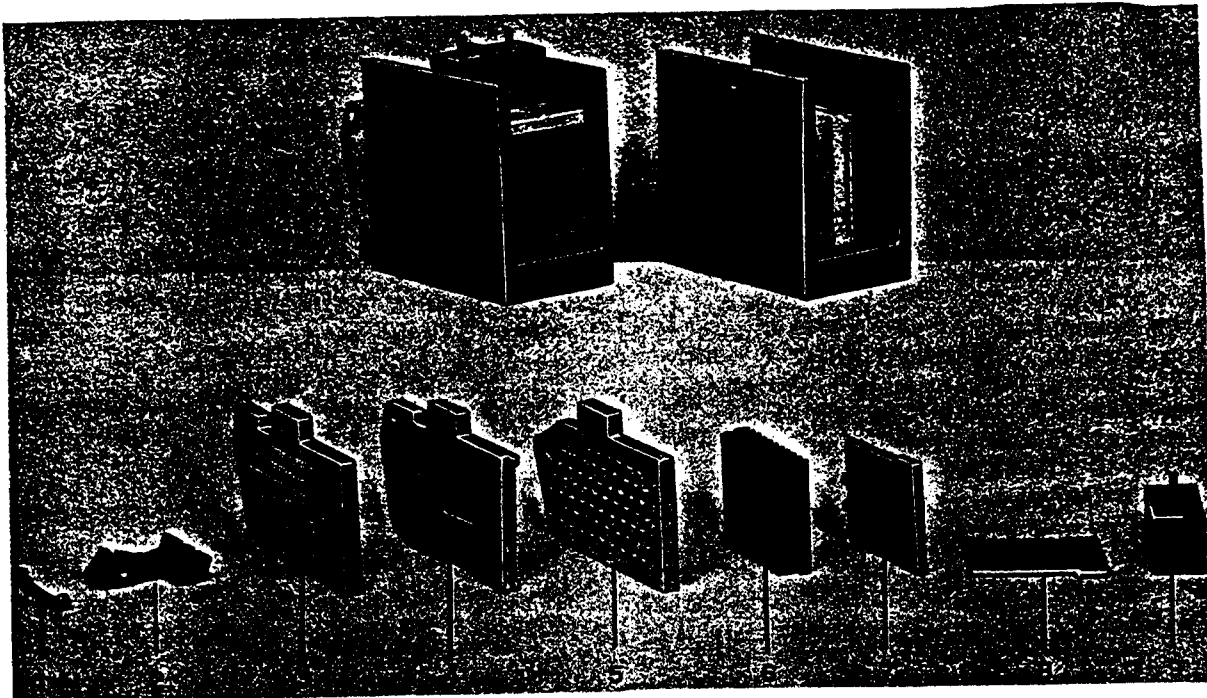

1. Stud
2. Cap
3. Side Barrier
4. Pocket Barrier
5. Inner Barrier
6. Muffler
7. Compound Support
8. Steel Back Plate
9. Spacer Block

Figure 4 Disassembly of Arc Quenchers - Standard Breaker and AKF Center Pole

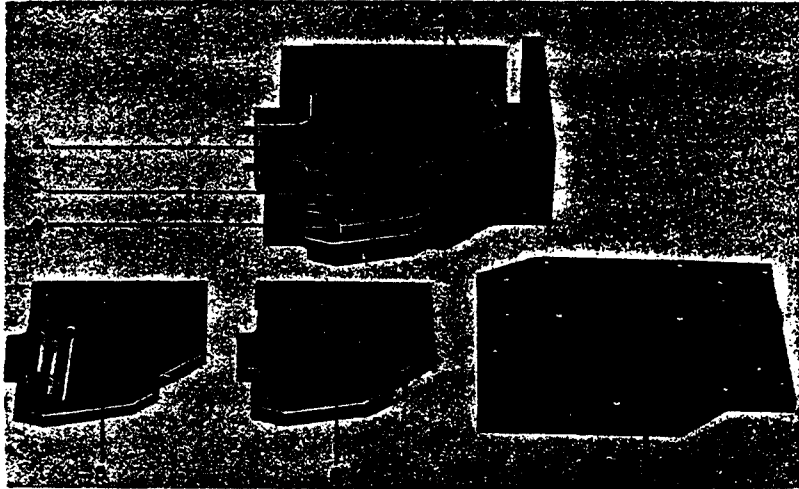

- | | |
|---------------------|-------------------------|
| 1. Muffler Assembly | 5. Intermediate Barrier |
| 2. Spacer Block | 6. Outer Barrier |
| 3. Inner Barrier | 7. Side Plate |
| 4. Cap | |

Figure 5 Disassembled Arc Quencher - AKF Outer Poles

1. Remove arc quenchers (see REPLACEMENT).
2. Remove screws holding spacer block (9).
3. Remove spacer block, steel back plate (8), and compound support (7).
4. Rock muffler (6) slightly and remove. The inner barriers (5) can now be removed for inspection.
5. Remove nut and withdraw stud (1).
6. Remove cap (2). The side (3) and pocket (4) barriers should be free.
7. Reassemble and replace the arc quencher in the reverse order. Tighten the fastenings after replacement.

**DISASSEMBLY-AKF OUTER
POLES (Fig. 5)**

1. Remove arc quenchers (see above) and lay on sides on a flat surface.
2. Remove hardware from one side of arc quencher as indicated in Fig. 5.
3. Remove bolt fastening cap (4) and barrier plate assembly.
4. Barrier plates may now be lifted from assembly for inspection.
5. In reassembling, make sure components are positioned so that holes for self-tapping hardware are in line. Do not strip threads in compound by overstressing screws.

ware are in line. Do not strip threads in compound by overstressing screws.

POLE UNIT ASSEMBLY (FIG. 6)

NOTE

The text and part identification numbers contained in this section apply to illustrations covering the AK-50 breaker. The same text is applicable to the AK-75 and 100 breakers by referring to Fig. 7 and identifying the similar parts. These similar parts may not, in every case, be identified by the same number.

Each pole unit assembly consists of a set of arcing contacts, a set of main contacts, the actuating linkage and the mounting base. See Fig. 8 and 9, pole unit assemblies mounted on back frame assemblies.

The stationary arcing-contact assembly consists of a set of parallel contact fingers (2), pin (3), and compression springs (22), which provide continuous contact pressure for the full travel of the contacts. Steel springs (5) shunt the pivot pin to prevent possible pitting at the pivot point when interrupting high currents. On earlier model breakers flexible braid leads were used.

The movable arcing-contact assembly consists of parallel contact arms (4) carried on two movable pivot pins (8) and (19). The arcing contacts interrupt the main contacts and pivot with them about pin (19). This relative motion is obtained by linkages from the upper pin (7) to the breaker mechanism.

TABLE I

Breaker Type	Main Contacts			Intermediate Contacts			Arcing Contacts		
	No. of Contacts Per Pole	Pressure in Lbs.	Wipe in Inches	No. of Contacts Per Pole	Pressure in Lbs.	Wipe in Inches	No. of Contacts Per Pole	Pressure in Lbs.	Wipe in Inches
AK-50 for AC	3	55 to 65	4/64 to 7/64	1	55 to 65	*	2	31 to 43	12/64 to 18/64
AK-50 for DC	3	55 to 65	1/16 to 7/64	1	55 to 65	*	3	31 to 43	12/64 to 18/64
AK-75 for AC	5	35 to 45	1/16 to 7/64	1	35 to 45	*	3	31 to 43	12/64 to 18/64
AK-75 for DC	5	35 to 45	1/16 to 7/64	1	35 to 45	*	5	31 to 43	12/64 to 18/64
AK-100 for AC AK-100 for DC	8	25 to 35	1/16 to 7/64	2	25 to 35	*	5	31 to 43	12/64 to 18/64
AKF-2C (Outside Poles)	3	55 to 65	1/16 to 7/64	1	55 to 65	*	2	31 to 43	12/64 to 18/64
AKF-2D (Outside Poles) AKF-2E (Poles)	5	55 to 65	1/16 to 7/64	1	55 to 65	*	3	31 to 43	12/64 to 18/64
AKF-2C (Field Discharge) AKF-2D (Discharge Contacts)	0	-----	-----	0	-----	--	2**	10 to 16	28/64 to 40/64

* The intermediate contact wipe should be at least 1/16 in. greater than main contact wipe.

** Left stationary contact extends approximately 3/32 in. + 1/32 further than right hand contact.

The stationary main contact assembly includes main and intermediate contacts. The intermediate-contact surface extends beyond the main contacts and will, therefore, make before the main contacts and break after the main contacts. The number of contacts for each breaker rating is given in Table 1.

The movable main contacts pivot around a stationary pin (18), which holds them to the lower block. Motion is obtained from a second pin (7), connected by an insulated link (12) to the breaker mechanism. In addition to steel springs shunting the current from the contact directly to the lower contact block, steel springs (17) force the contacts against the pins to prevent pitting at the pivot point. The movable main contact assembly also contains main and intermediate contacts.

In order to function properly, a definite amount of contact pressure and contact wipe must exist between the movable and stationary contacts. Table 1 gives the figures for contact pressure and contact wipe. Both wipe and pressure should be checked during the regular inspection period.

MEASURING CONTACT WIPE (Fig. 6)

1. Remove arc quenchers (see REPLACEMENT under ARC QUENCHER).
2. With the breaker open, measure the horizontal distance from the edge of the stationary contact to the stationary block behind it. ('B' dim. for arcing contacts, 'C' dim. for main contacts).
3. Close the breaker and repeat item 2. The difference between the readings in items 2 and

3 determines the wipe of the contacts. For safety reasons be extremely careful not to trip the breaker.

MEASURING CONTACT PRESSURE (Fig. 6)

1. Remove arc quenchers (see REPLACEMENT under ARC QUENCHERS).
2. Close the breaker and measure dimension 'B'.
3. Open the breaker. Place a push-type scale against the stationary arcing contacts at a point measured in line with the break between the contact stop and the contact pivot block. Push the contact backward until dimension 'B' recorded in item 2 is reached. The scale should then be read.
4. If the pressure is not within the requirements listed on TABLE I, refer to the following paragraphs.

ADJUSTING CONTACT WIPE AND PRESSURE (Fig. 6)

1. To obtain proper contact wipe and pressure on the center pole, dimension 'A' should be increased to increase wipe and decreased to decrease wipe.
2. To change dimension 'A' remove the clevis pin (14) and rotate the clevis as necessary.
3. To prevent overstressing the clevis threads (13) dimension 'A' should not exceed 3/16 in. and space 'A' should be filled with shims to 0.005 in. of being solid.

1. Screw
2. Stationary Arcing Contact
3. Pin (Stationary Arcing Contact)
4. Movable Arcing Contact
5. Spring (Leaf Contact)
- 5A. Stationary Intermediate Contact
6. Movable Main Contact
7. Shouldered Pin
8. Pin (Arcing Contact Links)
9. Insulating Link
10. Pin (Insulating Link)
- 10A. Adjusting Plate
- 10B. Buffer Spacers
11. Pin (Side Link)
12. Link
13. Clevis
14. Clevis Pin
15. Lower Stud
16. Pole Unit Base
17. Spring (Main Movable Contact)
18. Pin (Main Movable Contact)
19. Pin (Movable Arcing Contact)
20. Side Link
- 20A. Contact Stop
21. Spring (Stationary Main Contact)
22. Spring (Stationary Arcing Contact)
23. Upper Stud
24. Leaf Spring (Stationary Main Contacts)
25. Pin (Stationary Main Contact)
26. Stationary Main Contact
27. Screw
28. Stop

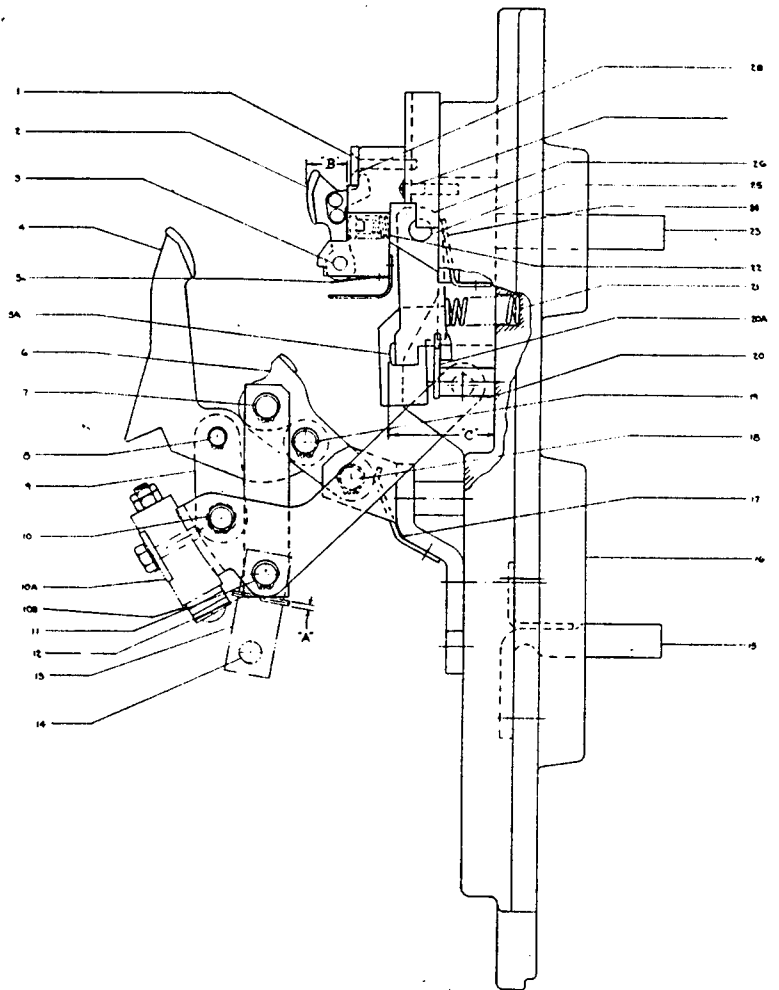

Figure 6 Pole Unit Assembly - AK-50

4. With the proper center pole wiper obtained, moving the crossbar adjusting plate (10A) on the center pole to the right will simultaneously increase the wiper on both outside poles; moving the adjusting plate to the left will have the reverse effect.
5. To increase the wiper on either outside pole individually, move the crossbar adjusting plate of that pole to the left; to decrease the wiper move the adjusting plate to the right.

NOTE

If the proper contact pressure does not exist when the contact wiper is within its limits, the stationary contact springs should be replaced.

CONTACT SEQUENCE (Fig. 6)

On the horizontal plane, the difference in the making of the arcing contacts on the same pole must be no greater than 1/32 in.; the difference between arcing contacts on separate poles 1/16 in. If it is desired to advance or retard the closing of the main contacts of a pole, loosen the bolts holding the ad-

justment plate (10A) of that pole and slide plate to the left to advance contact closing, or to the right to retard contact closing. Make this adjustment on the outer poles, using the center pole as a reference. Upon retightening adjustment plate bolts, make sure the locking tabs are turned up around bolt heads, locking the bolts securely in place.

Contact sequence in the vertical plane should be such that when the arcing contacts are just touching, the intermediate contact gap should be at least 3/16 in., the main contacts gap at least 1/4 in.

NOTE

This check can best be made by means of the maintenance handle, with the safety pin restraining the closing springs.

If the gap is under the required minimum, it is usually possible to form the arcing contacts to obtain the required dimensions. To form the contacts, place a piece of conduit approximately two feet long, over the contact and form the contact either forward or backward. If the proper dimen-

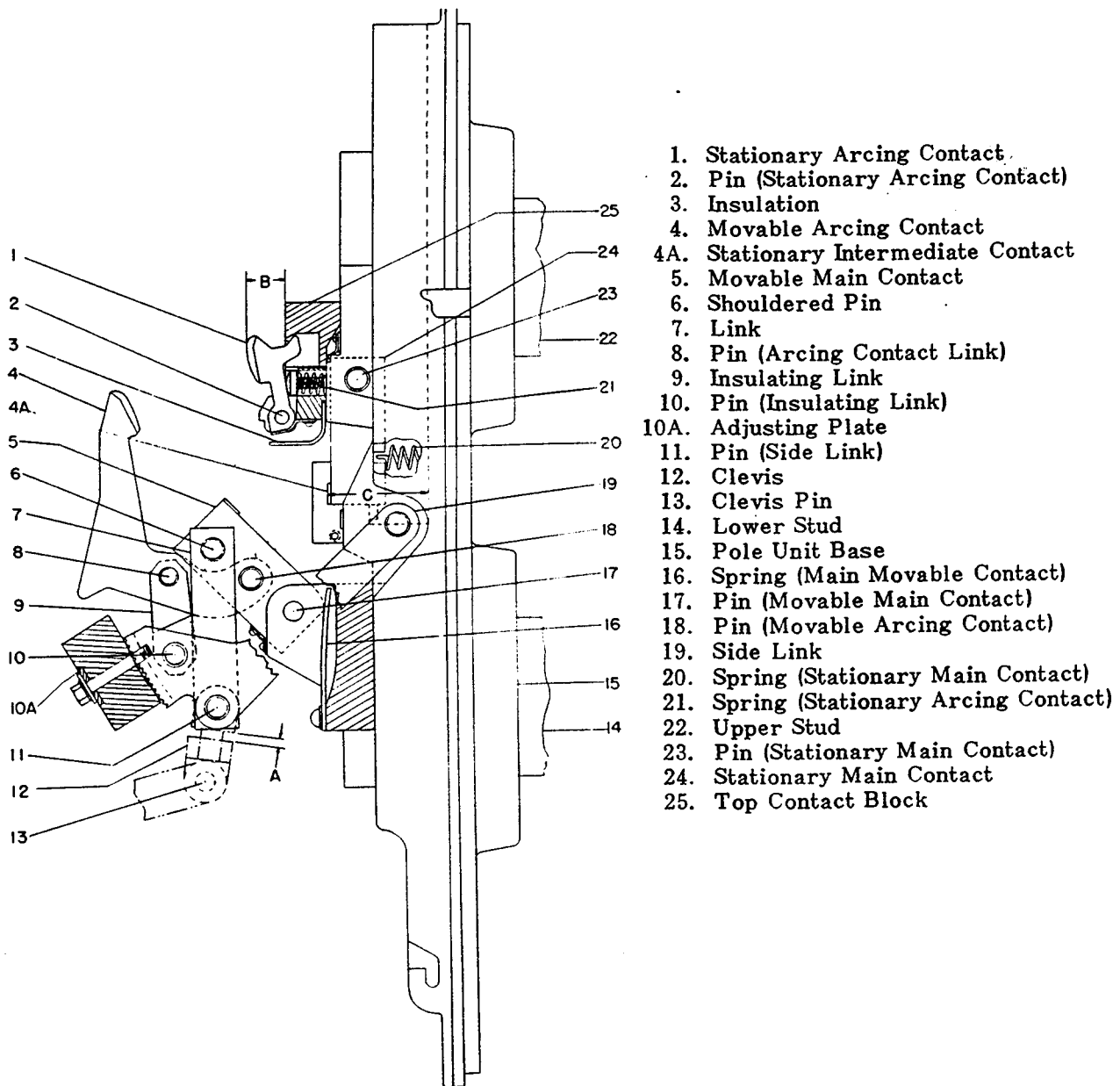

Figure 7 Pole Unit Assembly - AK-75 and AK-100

sions are still not obtained the movable arcing contacts should be replaced.

If it has been necessary to make any adjustments while obtaining proper contact sequence, the contact wipe and pressure must be checked, and adjusted, if necessary.

CONTACT GAP (Fig. 6)

When the breaker is open, the gap between the movable and stationary contacts should be between $2 \frac{5}{8}$ in. and $2 \frac{3}{4}$ in. The gap may be adjusted by varying the number of buffer spacers on the cross-bar. The locking nuts on the buffer bolts should be locked in such a position that the buffer bolt may be rotated freely.

REPLACEMENT OF CONTACTS (Fig. 6)

Stationary Arcing Contacts (2, Fig. 6) (1, Fig. 7)

1. Remove the upper plate by removing two screws (1). On the AK-75 and -100 remove the top contact block (25, Fig. 7) and remove insulation (3, Fig. 7).
2. Loosen screws holding spring (5).
3. Remove pin (3) freeing the stationary contacts and springs (22).
4. Install new springs and stationary arcing contacts in reverse order.
5. Adjust contact wipe and pressure. (See ADJUSTING CONTACT WIPE AND PRESSURE).

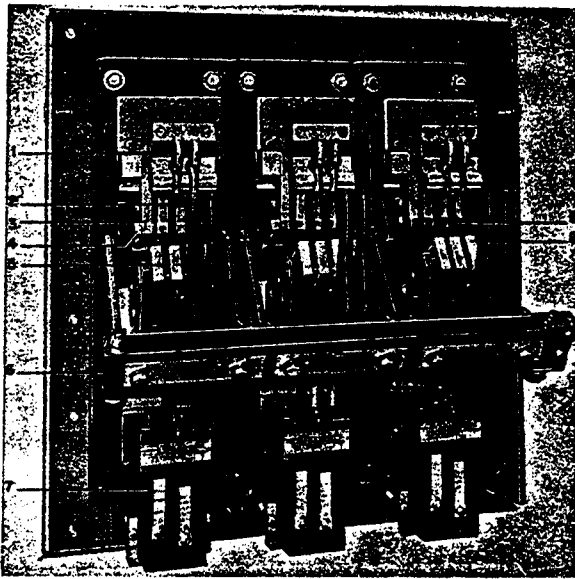

1. Stationary Arcing Contact
2. Movable Arcing Contact
3. Stationary Main Contact
4. Clamp
5. Movable Main Contact
6. Crossbar
7. Series Overcurrent Device
8. Movable Intermediate Contact
9. Stationary Intermediate Contact

Figure 8 Front View of Back Frame Assembly
AK-2-50

The movable arcing contacts (4) should be replaced when the stationary arcing contacts are replaced.

1. Separate the front frame from the back frame as described under SEPARATION OF FRONT AND REAR FRAMES.
2. Remove pins (8) and (19) and withdraw the contacts.
3. Reassemble parts in reverse order.

Stationary, Intermediate and Main Contacts (Fig. 6)

1. Remove stationary arcing contacts as described above.
2. Remove screws (27) and remove bracket which holds pin (25) in place.
3. Remove main-and intermediate-contact stop (20A) which holds the lower part of stationary contact. Removal will be facilitated if the force on the contact springs (21) is neutralized. This can be accomplished by operating the breaker with the maintenance handle, with the safety pin in place, until the load on the contact stop is relieved.

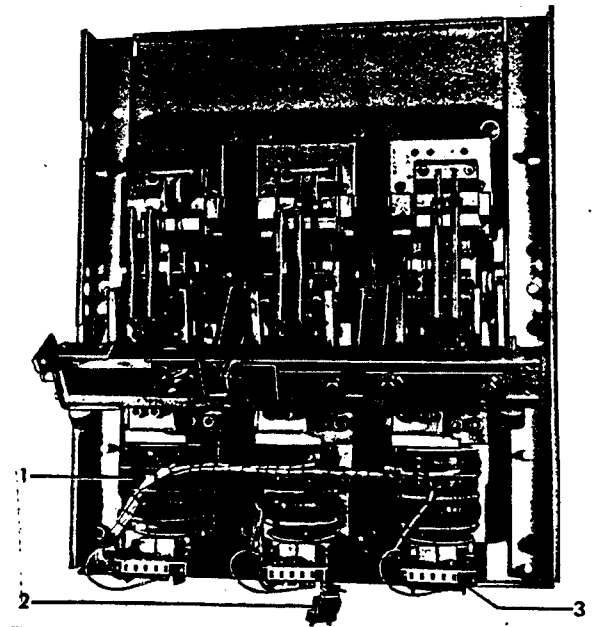

1. Power Sensor Coil Assembly
2. Disconnect Plug
3. Transformer Taps in Amperes

Figure 9 Front View of Back Frame Assembly
AK-3-50

4. Loosen the hardware which fastens the upper stud to the pole unit base until the contact spring load on pin (25) is relieved.
5. Remove pin (25) and screws (27) and lift out contacts.
6. Reassemble contacts in reverse order, being careful to replace the intermediate contact in the proper position.

Movable Intermediate and Main Contacts (Fig. 6)

1. Remove the movable arcing contacts as described above.
2. Loosen spring (17).
3. Remove braid if present by removing screw at bottom of contact.
4. Slide link (12) to the side and off of pin (7).
5. Slide pins (7) and (18) far enough to the side to allow the movable intermediate contacts to be replaced.
6. Reassemble parts in reverse order.

Always check contact wipe and pressure follo contact replacement.

(See ADJUSTING CONTACT WIPE AND PRESSURE).

OPERATING MECHANISMS

ELECTRICALLY OPERATED AK-50, -75 AND -100

The electrically operated mechanism includes a motor and a gear reduction unit, which charges the closing springs (16, Fig. 10) through a crank shaft (14, Fig. 10). The crank shaft has an arm with a roller (12, Fig. 10) which rides on the closing cam (2, Fig. 11). The position of this closing cam roller is shown in Fig. 11A, 11B, and 11C. The closing cam is connected to the center-pole unit through a clevis and through a crossbar it controls the opening and closing of the contacts on all pole units.

Charging the Closing Springs (Fig. 10)

1. The mechanism in position is shown in Fig. 11A.
2. The motor turns the crank (10) which is mounted on the output shaft of the gear reduction unit. The charging roller, which is on the face of the crank, has paddle arm (11) bearing on it.
3. As the crank turns, the roller pushes the paddle arm upward, thereby charging the closing springs through the spring charging arm (15) of the crank shaft.
4. As the charging roller approaches dead center a cut-off switch opens, de-energizing the motor circuit.
5. The breaker is now ready to close when a closing signal is given.
6. With the breaker resting at the precharge position, the trip latch may or may not be in the reset position. This depends on the position of roller (15, Fig. 11B) with respect to the cam (2, Fig. 11B).

Closing the Breaker Electrically Operated (Fig. 10)

1. With the mechanism in the position described above and the closing springs charged, applying a closing signal will cause the motor to continue to charge the closing springs allowing the mechanism to reset, if not already reset, to the position shown in Fig. 11B.
2. As the crank roller (7) passes its top dead-center position, (maximum spring charge position) the closing springs are free to discharge. Crank (10) can be overdriven independently of the motor so that roller (7) assumes its bottom dead-center position without restraint.

As the springs discharge, the rotation of the crank shaft (14) causes roller (15, Fig. 11) to rotate cam (2, Fig. 11) and raise clevis (13, Fig. 11). Prop (16, Fig. 11) holds cam (2, Fig. 11C) in this position.

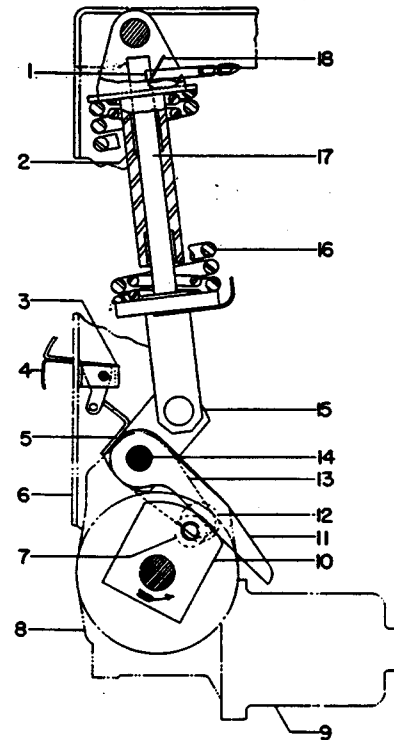

- | | |
|-------------------|---------------------|
| 1. Pin | 11. Paddle |
| 2. Bushing | 12. Closing Cam |
| 3. Bracket | 13. Closing Cam |
| 4. Indicator | 14. Crank Shaft |
| 5. Bracket | 15. Spring Charging |
| 6. Frame | 16. Closing Spring |
| 7. Crank Roller | 17. Push Rod |
| 8. Gear Reduction | 18. Clip |
| 9. Motor | |
| 10. Crank | |

Figure 10 Closing Spring and Charging Mechanism

4. Raising clevis (13, Fig. 11C) closes the breaker contacts through the pole base linkage.

Tripping the Breaker (Fig. 11)

Operation of any of the trip devices rotates the trip shaft (11) which allows the trip latch (10) to release the latch prop (5). This allows the forces of the contact and opening springs to reposition the operating mechanism linkage to the position shown in Fig. 11A. In this position, the operating cycle may be repeated.

Adjustments (Fig. 11)

All adjustments should be made with the operating mechanism in the reset position as shown in Fig. 11B. (The mechanism should be reset by manual operation with the safety pin in place and with roller (15) clear of cam (2).

1. The gap between the trip latch (10) and the roller (9) of the reset latch should be between

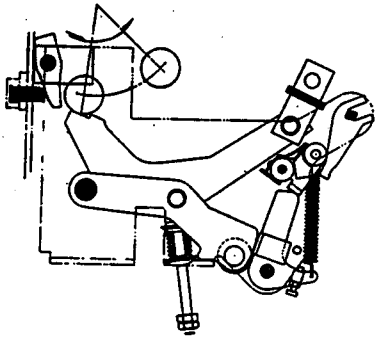

Figure 11A Mechanism in Motion Before Re-
setting As Shown in Figure 11B

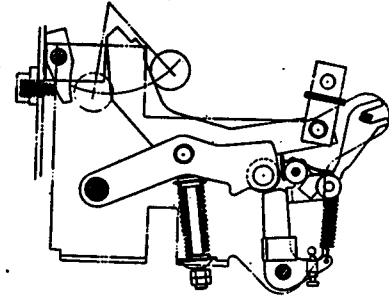

Figure 11B Mechanism in Reset Position

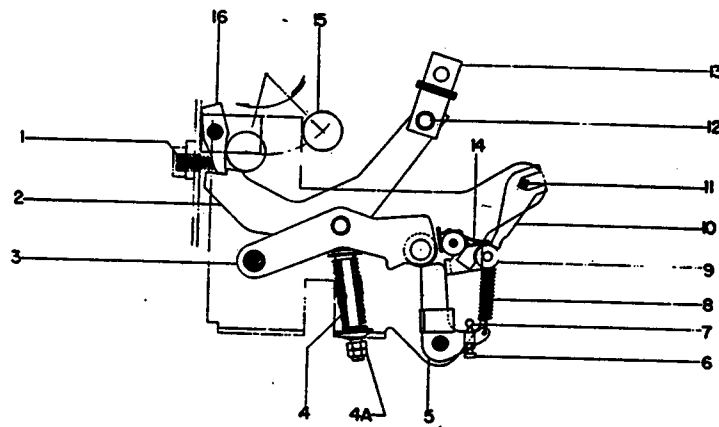

Figure 11C Mechanism in Closed Position
(Closing Spring Discharged)

- | | |
|-----------------------------|--|
| 1. Spring | 9. Roller |
| 2. Cam | 10. Trip Latch |
| 3. Link | 11. Trip Shaft |
| 4. Reset Spring | 12. Clevis Pin |
| 4A. Spring Adjusting Nuts | 13. Clevis |
| 5. Prop | 14. Latch Buffer Stop
(Bronze Material) |
| 6. Adjusting Screw | 15. Roller |
| 7. Adjusting Screw Stop Pin | 16. Prop |
| 8. Prop Return Spring | |

Figure 11 Operating Mechanism

- 1/64 in. and 1/32 in. This adjustment can be obtained by turning screw (6).
- The center line of the trip latch (10) should pass through the center of the roller (9). The latch buffer stop on the mechanism frame can be adjusted by loosening the retaining screws to reposition the latch with respect to the roller.
 - The distance between the roller on link (3) and prop (5) should be between 1/64 in. and 1/32 in. To obtain this gap, advance or retard the nuts (4A) on the bottom of the rod using the reset spring (4).

Replacement

When replacing the operating mechanism, refer to the section titled SEPARATION OF FRONT AND BACK FRAMES under MAINTENANCE in these instructions.

The motor is mounted on the side of the gear-reduction unit and through a worm gear and a planetary gear train drives the crank (10, Fig. 10) with a reduction 1000:1. To remove the motor and gear-reduction unit, proceed as follows:

- Remove the front frame (see SEPARATION OF FRONT AND REAR FRAME).
- Remove closing springs and crank-shaft as illustrated in Fig. 12 and 13.

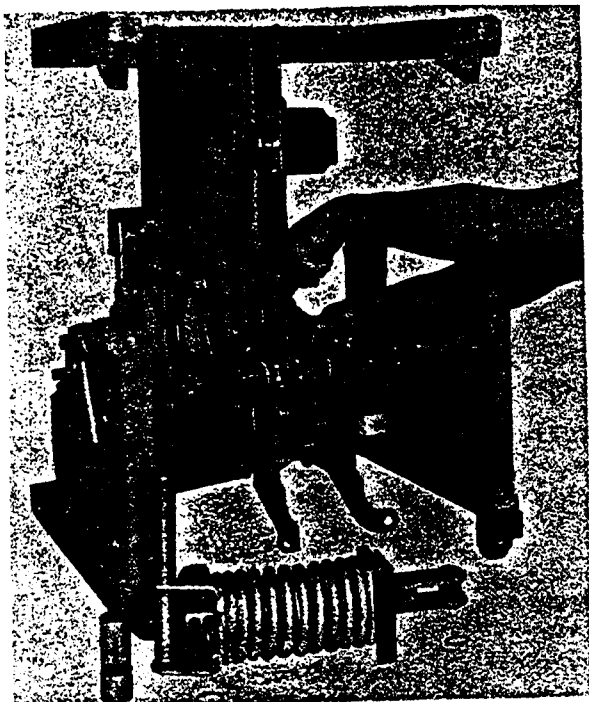

Figure 12 Rear View of Front Frame - AK-50 Showing Cam Shaft Locking Plate Being Loosened

- Disconnect the leads from motor and remove the wires attached to gear unit housing.
- Remove four bolts at the bottom of the front frame and one bolt at top of gear reduction unit. The motor and gear unit may now be removed.

NOTE

If it is desired to replace only the motor unit, disconnect the motor leads and remove only the hardware fastening it to the gear-reduction unit. When removing the motor only, the front frame should be placed front side down to prevent the oil escaping from the gear unit.

The gear reduction unit contains 4 ounces of oil similar to Atlantic Refining Company's Grade HFS No. 3. It should not be necessary to add or change oil except when the gear-reduction unit and motor are disassembled.

QUICK CLOSE BREAKER ADJUSTMENTS

The quick close breaker basically differs from the standard breaker in that the precharging operation is extended to and slightly past the top dead center position of the closing spring assembly. As the springs start to discharge to close the breaker, the discharge operation is arrested by a prop and latch arrangement. The subsequent closing operation

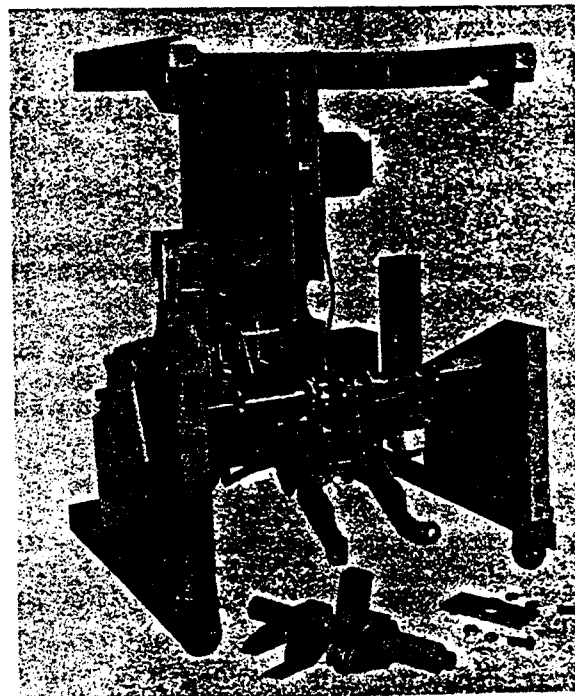
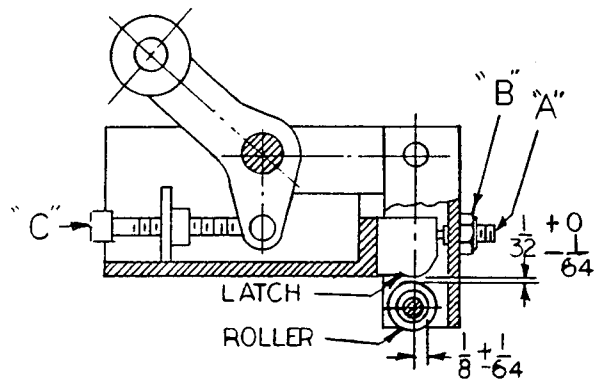
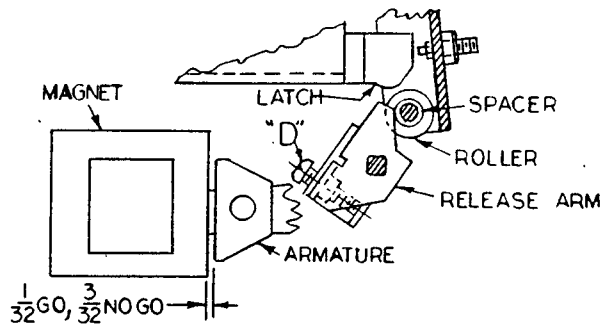

Figure 13 Rear View of Front Frame - AK-50 Showing Cam Shaft Locking Plate And Cam Shaft Removed



Adjust the engagement of the roller on the latch to $1/8'' \pm 1/64''$ by turning the screw 'A'. After adjustment is set, lock the bolt with the hex nut 'B'. Adjust the clearance between the latch and the roller to $1/32'' + 0 - 1/64''$ by turning the screw 'C'.

Figure 14A Quick-Closing Release Latch



Adjust release arm screw 'D' so that the stroke of the armature of the closing solenoid releases the roller from the latch with a minimum of $1/32''$ over-travel. Check by using $1/32''$ GO and $3/32''$ NO GO gauge between armature and magnet.

Figure 14B Release Arm Adjusting

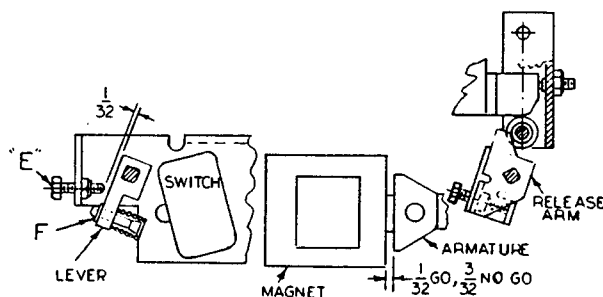

Adjust screw 'E' to $1/32''$ clearance between screw and lever with clearance on release arm taken up by pressing lever lightly forward.

Adjust switchette operation by adding washers 'F' under cotter pin, so that contact is made when armature is adjusted as shown above.

Figure 14C Release Shaft Stop and Switchette

is accomplished by tripping the latch to release the prop which in turn allows the springs to continue the interrupted discharging operation and close the breaker.

The gear reduction unit for the standard breaker is not interchangeable with the gear reduction unit on the quick close unit because the quick close gear reduction unit employs a slip clutch to relieve the pressure that would otherwise be exerted between the output crank plate and the prop.

After the closing springs have been completely charged and the prop and latch system are preventing closure of the breaker, the closing opera-

tion may be accomplished by energizing the closing relay thru the control relay contacts, or manually by depressing the push to close lever which mechanically displaces the latch to allow the breaker to close.

On drawout breakers an interlock between the breaker and enclosure requires the springs to be discharged before the breaker can be removed from the enclosure.

The control relay or (X) relay is located on the left side of the front frame channel. It may be removed by disconnecting the wiring, loosening the (3) two mounting screws and lifting it slightly to

admit the top mounting screw through the keyhole mounting. In general, the entire relay should be replaced rather than changing coils and contacts.

The anti-pump relay is located on the left side of the front channel above the control relay. The connections to this relay are soldered. Removal of the relay is straight forward. When re-installing use extreme care to avoid shorting contact points of different voltage potential with solder or flux.

The closing control relay consists of a strong box solenoid with sufficient linkages to operate the remotely located D switches.

STORED ENERGY MANUAL MECHANISM

This breaker is equipped with a spring-charged stored-energy mechanism similar to the mechanism used on the AK-50, -75 and -100 electrical breakers. The closing springs (5) are charged by operating the manual closing handle (22) on the front of the breaker, instead of the closing motor as is the case with the electrical breaker. Closing this breaker is accomplished by pumping the operating handle four complete cycles, first counterclockwise through 120 degrees from its normal vertical position and then clockwise back through 120 degrees from its normal vertical position and then clockwise back through 120 degrees. When approximately 70 degrees of the fourth clockwise stroke have been completed, the closing springs, which have been charged during the previous strokes of the closing handle, are driven over-center and the breaker closes.

This mechanism consists basically of a closing spring assembly, ratchet wheel and output crank assembly, handle shaft and pawl assembly, and the closing handle.

CLOSING THE BREAKER (Fig. 15)

The first stroke of the closing handle causes the ratchet pawls (21) attached to the handle shaft (23), to engage the first tooth of the ratchet wheel (17), thus beginning to charge the closing springs. The subsequent closing handle strokes perform the same function as the pawls (21) engage the teeth in the ratchet wheel (17), thus rotating the ratchet wheel and output crank (32) and completely charging the closing springs. This rotation of the ratchet wheel and output crank is in a counterclockwise direction from the lower position, through slightly more than 180 degrees, to a position just beyond dead center. In this position the closing springs are free to release their energy, closing the breaker at a high speed.

INSERTING THE SAFETY PIN (Fig. 15)

If it is desired to slowly close the breaker contacts check contact wipe and sequence, operate the closing handle 3 1/2 complete cycles as described above. At the end of the fourth counterclockwise stroke and before performing the fourth clockwise stroke, insert the safety pin (3) into the hole (4)

in the guide rod (6), thus preventing the closing springs (5) from releasing their energy to close the breaker contacts.

REPLACEMENT (Fig. 15)

If it is necessary to replace any of the mechanism parts, the following total procedure is recommended. This procedure may be halted at the step required to replace any particular part:

1. Install the safety pin (3) as described above.
2. Separate the front and rear frames as described under 'SEPARATION OF FRONT AND REAR FRAMES' in the 'MAINTENANCE' section of these instructions.
3. Remove the closing spring assembly by removing the upper and lower spring pins (1, 31).
4. Remove the right hand bearing side plate (20), and the side plate shims (18) if present, by removing four mounting bolts (19), thus allowing the main closing crank (25) to be removed.
5. Remove the closing handle (22) by removing two set screws threaded in same hole.
6. Remove the front escutcheon by removing four screws holding it to the front frame center support.
7. Remove the handle return spring (29) by unhooking either end of the spring.
8. Disconnect the top end of each pawl spring (7).
9. Remove the roll pin (24), thus allowing the closing handle shaft (23) and pawl assembly (23) to be removed.
10. Remove the ratchet wheel (17) and its assembly (16) by removing Nylok screw (15) and thrust bearing (12). If shims (13) are present they must also be removed.
11. Remove front bearing plate (9) by removing three mounting bolts (10) accessible from the front of the breaker. The mechanism is now completely disassembled. It is not recommended that any of the subassemblies removed during the above operation be further disassembled in the field. Replacement sub-assemblies should be obtained from the factory.
12. To reassemble the mechanism, reverse the procedure described above.

NOTE

When reassembling the mechanism the adjustments listed below should be checked at the appropriate time of reassembly. The appropriate time for each adjustment is indicated in the adjustment text.

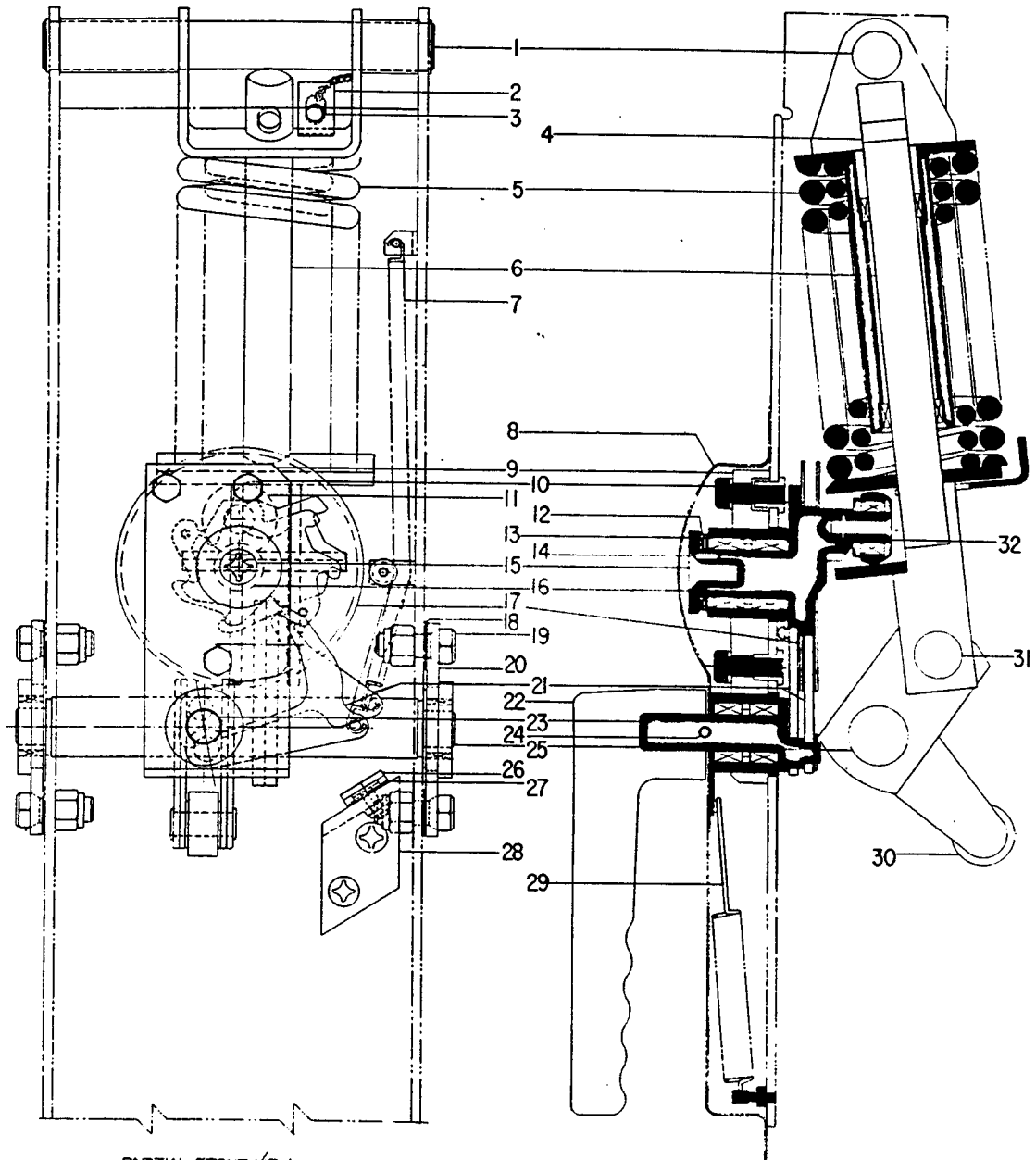

PARTIAL FRONT VIEW
WITH HANDLE AND ESCUTCHEON REMOVED

- | | | |
|----------------------------------|----------------------------------|--|
| 1. Upper Spring Pin | 12. Thrust Bearing | 23. Closing Handle Shaft and Pawl Asm. |
| 2. Safety Pin Holder | 13. Shims | 24. Roll Pin |
| 3. Safety Pin and Chain | 14. Groove Pin | 25. Main Closing Crank |
| 4. Safety Pin Hole | 15. Nylok Screw | 26. Pawl Buffer Stop |
| 5. Closing Springs | 16. Ratchet Wheel Shaft and Asm. | 27. Buffer Stop Shims |
| 6. Guide Rod | 17. Ratchet Wheel | 28. Buffer Stop Support |
| 7. Pawl Springs | 18. Side Plate Shims | 29. Handle Return Spring |
| 8. Front Escutcheon | 19. Side Plate Mounting Bolts | 30. Mechanism Roller |
| 9. Front Bearing Plate | 20. Bearing Side Plate | 31. Lower Spring Pin |
| 10. Bearing Plate Mounting Bolts | 21. Ratchet Pawls | 32. Output Crank |
| 11. Output Crank Roller | 22. Manual Closing Handle | |

Figure 15 Stored-Energy Manual Closing Mechanism Charged Position AK-2

ADJUSTMENTS (Fig. 15)

Frequent adjustments to the mechanism should not be required. If the mechanism has been disassembled, it will be necessary to check the following adjustments:

1. It may be necessary to add shims (13) to reduce the end play of the ratchet wheel shaft (16). An end play of 0.010 to 0.020 of an inch is recommended. Shims should be obtained from the factory.
2. It may be necessary to add buffer stop shims (27) to the buffer stop (26) to provide a clearance of 1/64 to 1/32 inch between the pawls (21) and the buffer stop, when the pawls are touching the ratchet wheel teeth extending a maximum distance from the center of rotation of the ratchet wheel (17). This measurement should be made while operating the closing handle during the four spring charging operations and before the closing springs are re-assembled.
3. The ratchet pawls (21) should operate freely throughout the closing strokes. They should engage the ratchet wheel teeth near the end of each counterclockwise and clockwise stroke of the closing handle with a definite clicking sound, indicating a free non-binding operation. After the clicking sound is detected, the closing handle should have a minimum overtravel of 1/2 in. or 3 1/2 degrees, measured at the end of each handle stroke.
4. The groove pin (14) in the front of the ratchet wheel assembly (16) must be assembled in a manner that will allow Nylok screw (15) to be tightened securely. A clearance of 1/64 to 1/32 in. should exist between the front of the groove pin and the rear surface of the Nylok screw head.

Other adjustments to the closing and operating mechanisms, such as complete contact and latch adjustments, may be made by following the previously described instructions for the AK-50, -75 and -100 breaker mechanisms.

AKF MECHANISM (FIG. 17)

The Type AKF breakers are two-pole breakers with field discharge contacts placed in the center pole. When this breaker is opened, the field discharge contacts close, thus connecting an external discharge resistor across the field of the generator or motor. When the breaker is closed, the field discharge contacts are opened. See Fig. 16 for a typical circuit connection.

When the breaker is tripped, the opening springs pull crossbar (9) downward, opening the breaker's outer poles. As the crossbar moves downward, link (A) rotates about a fixed center (17), collapsing

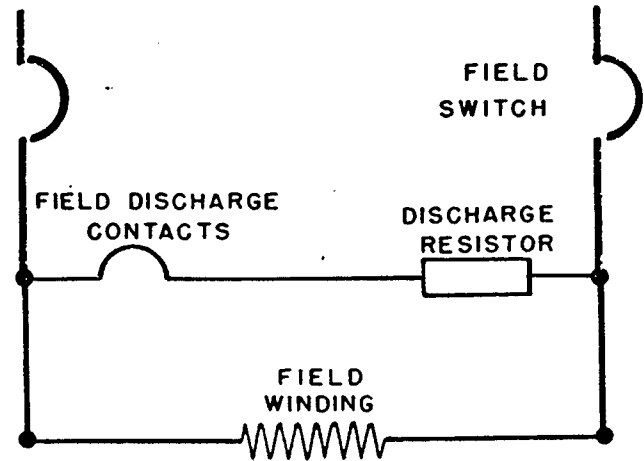

Figure 16 Typical Connection Diagram

toggle links (B) and (C) upward, thereby closing center-pole contacts through connecting link (D). Link (C) consists of two links riveted together, forming a single triangular link.

CONTACT ADJUSTMENTS

Measurements

For contact measurements and adjustments of the two outside poles of the breaker, refer to POLE UNIT ASSEMBLY.

Contact measurements of the center-pole field discharge contacts should be made on the left contact and be within the following limits:

1. Contact wipe, 3/16 in. to 7/16 in.
2. Contact pressure, 10 lb. to 16 lb.
3. Gap between contacts when center pole is open, 1 1/2 in. to 1 3/4 in.
4. Overlap between the center-pole contacts and the arcing contacts of the outer poles, 3/16 in. to 7/16 in.

Measurements of the center-pole contact wipe and pressure may be made by following the same procedure as outlined for the standard pole unit in POLE UNIT ASSEMBLY. Overlap of the center-pole contacts and the outer pole arcing contacts may be checked by the following procedure:

1. Remove arc quenchers (see ARC QUENCHER).
2. Insert safety pin in push rod. (See Fig. 3 under MAINTENANCE).
3. Operate closing mechanism with maintenance handle until arcing contacts of outer poles just touch.

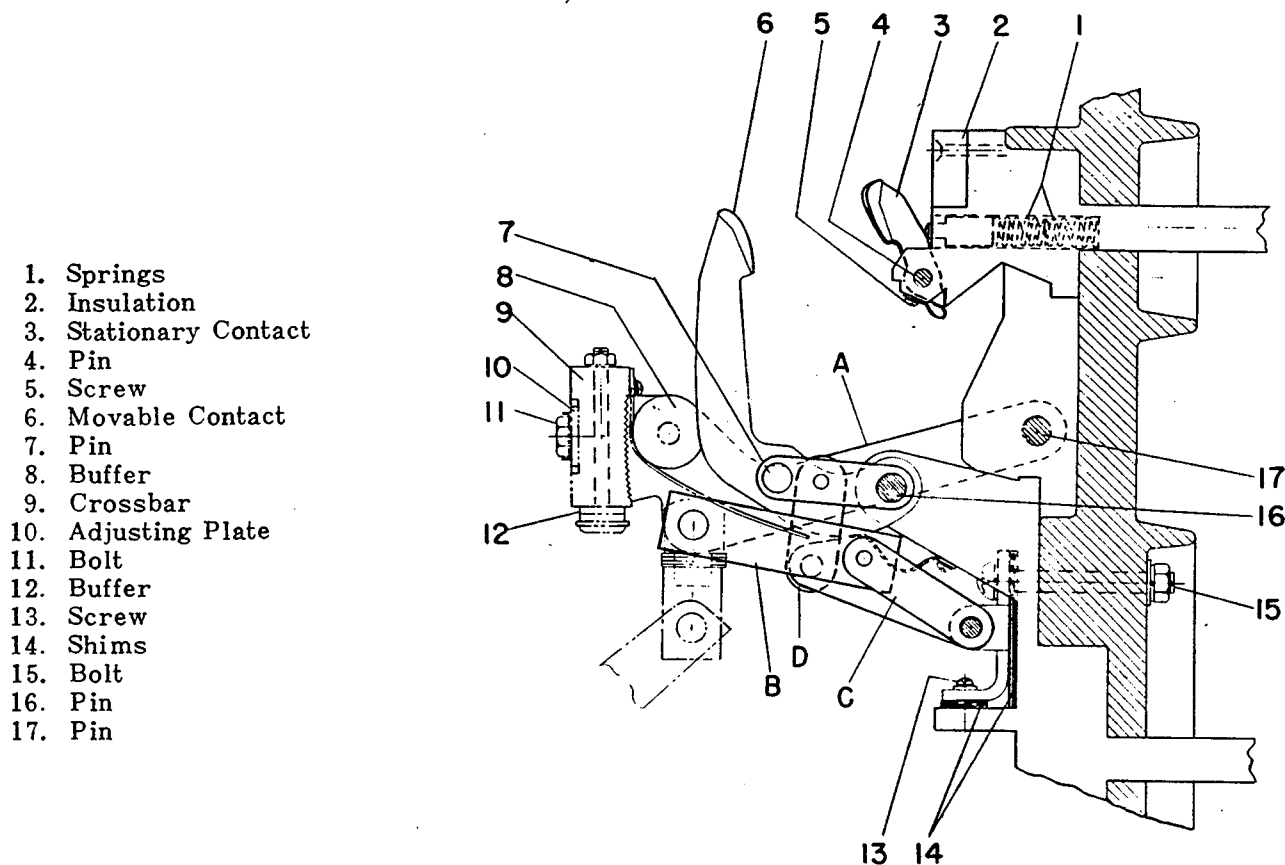

1. Springs
2. Insulation
3. Stationary Contact
4. Pin
5. Screw
6. Movable Contact
7. Pin
8. Buffer
9. Crossbar
10. Adjusting Plate
11. Bolt
12. Buffer
13. Screw
14. Shims
15. Bolt
16. Pin
17. Pin

Figure 17 Field Discharge Contacts (Center Pole)

4. Measure distance between forward edge of left stationary contact of center pole and surface of insulation block behind contact.
5. Continue to operate maintenance closing handle until center-pole contact opens fully.
6. Repeat measurement described in step 4. Difference between measurements indicates amount of overlap.

Adjusting Center-pole Contact Wipe and Overlap (Fig. 17)

If measurements reveal either incorrect center-pole contact wipe or incorrect overlap of contacts, adjustments should be made by the following procedure:

1. With outside poles open, loosen adjustment plate (10) of center pole on crossbar (9) by freeing bolt locking tab and loosening bolts (11).
2. If center-pole wipe or overlap is to be increased, move the adjustment plate to the left; if it is to be decreased, move it to the right.
3. After proper adjustment is made, tighten adjustment plate bolts until plate is snug. Then tap adjustment plate in such a way as to bring

lower edge of slot in plate to bear against bolt. Tighten bolt until lockwasher is fully compressed. Then form locking tabs over bolt heads so that bolts are securely held in place.

NOTE

If the above adjustment has been made, it is necessary to recheck the outer-pole wipe. If this is outside the prescribed limits, correct as described in POLE UNIT ASSEMBLY.

4. If proper wipe cannot be obtained within the range of the adjustment described above, it will be necessary to obtain further adjustment by means of the vertical shims (14) provided for the purpose. In order to accomplish this, proceed as follows:
 - a. Separate the front frame from the back frame (see SEPARATION OF FRONT AND REAR FRAMES).
 - b. Loosen screw (13) and remove bolt (15).
 - c. Remove vertical shims (14) to decrease wipe; add to increase.
 - d. Replace bolt (15) and tighten screw (13).

e. Reassemble front and back frame.

Adjusting Center-pole Open Contact Gap (Fig. 17)

Improper open contact gap of the center pole may be adjusted by the following procedure.

1. Loosen screw (13) and bolt (15).
2. If gap is to be increased, horizontal shims (14) should be removed. If it is to be decreased, they should be added. Shims may be removed by sliding them to the front of the breaker. They are slotted for easy removal. (Effect of this adjustment on contact wipe and overlap is negligible).
3. Tighten hardware.

CONTACT REPLACEMENT

Stationary Contacts (Fig. 17)

1. Remove arc quencher (see ARC QUENCHER).
2. Remove screw (5) from braid.
3. Drift out pin (4) and remove contacts.
4. Reassemble in reverse order with new contacts.
5. Check contact overlap and wipe, and readjust if necessary (see above).

Movable Contacts (Fig. 17)

1. Remove arc quencher (see ARC QUENCHER).
2. Remove tru-arc retainers on right side of pins (7) and (16).
3. Drift pins (7) and (16) to the left far enough to free movable contacts.
4. Reassemble in reverse order with new contacts.
5. Check contact overlap and wipe and readjust if necessary (see above).

AUXILIARY SWITCH

AK BREAKERS (Fig. 18)

The auxiliary switch is used to make and break various control circuits as the circuit breaker is opened and closed. The auxiliary switch is mounted on the left side of the front frame. As the crossbar (4) moves, with the contacts, to the open or closed position it operates a triangular link (6) through an operating rod (5). The triangular link rotates the operating shaft (8) of the auxiliary switch, which, through cams located on this shaft, opens and closes the auxiliary switch contacts. The top terminals of the switch are 'a' contacts (open when the breaker is open) and the bottom terminals are 'b' contacts (closed when the breaker is open).

Replacement (Fig. 18)

1. Disconnect all leads to auxiliary switch.

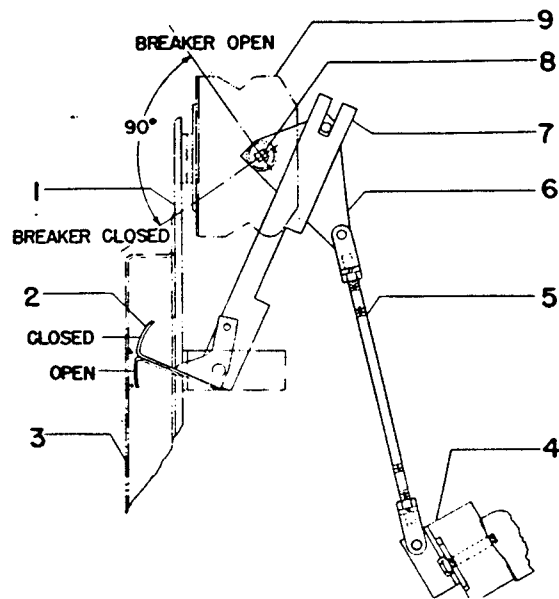

1. Frame
2. Open & Closed Indicator
3. Front Eschutcheon
4. Crossbar
5. Operating Rod
6. Triangular Link
7. Link
8. Operating Shaft
9. Auxiliary Switch

Figure 18 Auxiliary Switch Linkage
- Standard Breaker

2. Remove two mounting bolts.
3. Disengage auxiliary switch shaft (8) from the triangular link (6).
4. Set arrow on new auxiliary switch shaft.
5. Push auxiliary switch shaft (8) into square hole in link (breaker open).
6. Replace mounting hardware and wiring.

Adjustment (Fig. 18)

The 'a' contacts of the auxiliary switch should close before the arcing contacts of the breaker close. This may be checked by slowly closing the breaker with the maintenance handle, with the safety pin restraining the closing springs, and with a bell set across the 'a' terminals of the auxiliary switch.

The closing of the 'a' contacts can be advanced or retarded by extending or reducing the external length of the operating rod (5). The length of the operating rod (5) should be adjusted so that the switch 'a' contacts close when the arcing contacts are parted by 1/8 to 1/4 in. The operating rod should also be aligned vertically so that it is parallel with the sides of the breaker frame center channel and perpendicular with the crossbar (4). This alignment may be

1. Mounting Bolt
2. Tie Bolt
3. Shaft
4. Screw
5. Bottom Cover
6. End Plate
7. Top Cover
8. 'a' Contacts
9. Contact Spring
10. Rocker Arm
11. Pin
12. Cam
13. 'b' Contacts
14. 'b' Terminals
15. 'a' Terminals
16. Barrier

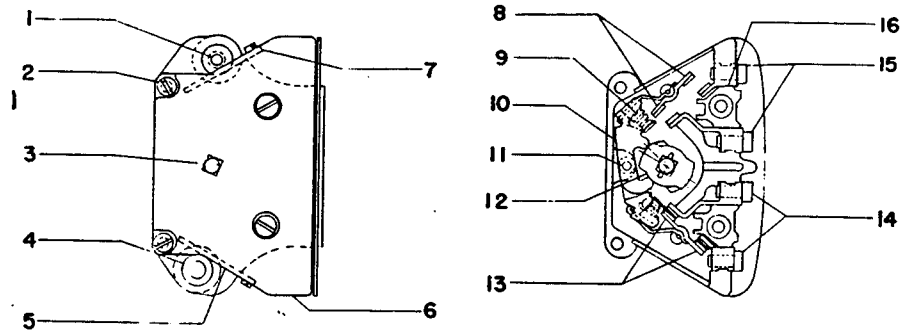

Figure 19 Auxiliary Switch - Standard Breaker

secured by relocating the washers on the pin which connects the operating rod to the crossbar.

AKF BREAKERS (Fig. 20)

The auxiliary switch mounting and linkage on the AKF breakers are different from that of the standard AK breakers. Figures 18 and 20 show the difference in the mounting positions, with the AKF switches rotated 90 degrees with respect to the mounting position of the standard breaker switch. There is also a slight difference between the linkage of the AKF breaker switches, however the principle of operation remains the same.

When the breaker operates, the movement of the crossbar (4) rotates triangular link (11) about fixed center (1). This rotational motion is transmitted to the auxiliary-switch shaft (3) by the linkage comprised of links (10), (8) and (6). The breaker position indicator is also operated by this mechanism through link (12).

Replacement (Fig. 20)

1. Disconnect all leads to auxiliary switch.
2. Remove mounting bolts (2) and (7).
3. Withdraw auxiliary switch.
4. Insert new switch with arrow on shaft pointing up and towards the back of the breaker as in Fig. 20.
5. Replace mounting hardware and wiring.

Adjustments (Fig. 20)

The auxiliary switch operating rod (5) should be adjusted so that the switch 'a' contacts close when the arcing contacts of the outer poles are parted by 1/8 to 1/4 in. This dimension may be checked in the same manner described for the standard

breakers. The length of the operating rod may be varied by changing dimension 'a' (see Fig. 20) and aligning the operating rod as described for the standard breakers.

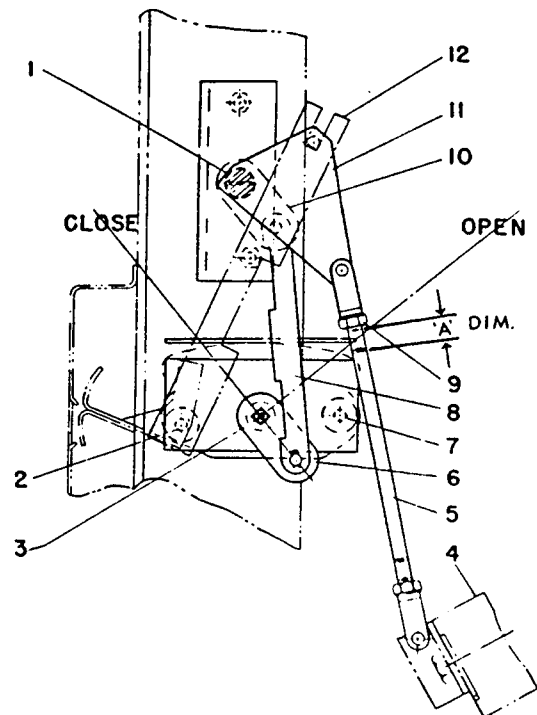

- | | |
|---------------------------|---------------------|
| 1. Pin | 7. Bolt |
| 2. Switch Mounting Bolt | 8. Link |
| 3. Auxiliary Switch Shaft | 9. Lock Nut |
| 4. Crossbar | 10. Link |
| 5. Operating Rod | 11. Triangular Link |
| 6. Link | 12. Link |

Figure 20 Auxiliary Switch Linkage - AKF Breakers

ELECTRICAL CLOSING DEVICES AND CONTROLS

A closing switch and motor mechanism are provided for closing the breaker electrically.

CLOSING SWITCH

The closing button, when provided is mounted on the front frame behind the escutcheon. A hole is provided in the escutcheon to allow operation of the switch. Remove the escutcheon to gain access to the switch.

CUT-OFF SWITCHES (FIG. 21)

The motor cut-off switches are mounted on the side of the front frame. When the breaker control circuit is energized the motor circuit is maintained through the closed contacts of switch (1), thus charging the closing springs. At the end of the charging stroke the cut-off switch is mechanically operated by the charging of the springs and through the operating rod (4), thus opening switch (1) contacts and closing switch (3) contacts. This opens the motor circuit until a closing signal is given.

When a closing signal is given the motor is energized through switch (3) contact, further charging the closing springs and closing the breaker. When the breaker closes, the cut-off switch is again mechanically operated, reverting to its original position with switch (1) contact now closed and switch (3) open, thereby allowing the motor to charge the closing springs for a subsequent closing operation. Most breakers have two normally open auxiliary contacts in series with the motor circuit to prevent pre-charging the closing springs with the breaker closed.

If the switches do not function properly, they should be replaced by disconnecting the wiring and removing them from their mounting bracket.

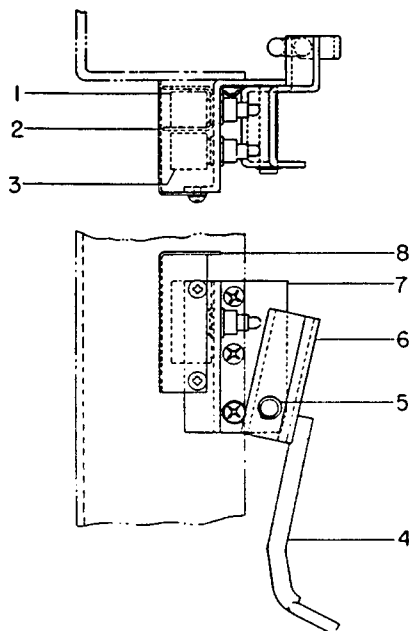

- | | |
|---------------|---------------------|
| 1. 'G' Switch | 5. Retaining Ring |
| 2. Insulation | 6. Lever Bracket |
| 3. 'F' Switch | 7. Mounting Bracket |
| 4. Rod | 8. Cover |

Figure 21 Motor Cut-Off Switch

CONTROL RELAY

The control relay is mounted on the left side of the front frame. It is used to open and close the motor circuit. To replace, remove wiring and holding screws. 3, (Fig. 2)

PROTECTIVE DEVICES

STATIC TIME DELAY UNDER-VOLTAGE TRIPPING DEVICE (FIG. 22)

The Static Time Delay Undervoltage Tripping Device consists of an undervoltage device mounted in the breaker, a static time delay box mounted separately from the breaker and a control power transformer if the voltage is other than D.C., 208V AC or 230V, AC. Refer to wiring diagram 0102C-3698 (Fig. 23).

The voltage 208V AC or 230V AC, to be monitored is connected to Terminals #1 and #2 of the time delay box. The undervoltage device on the breaker is always connected through either its secondary disconnects or terminal board, to terminals #4 and #5 of the time delay box.

The undervoltage device is set to pickup at approximately 80% of bus voltage and drop out between 3% and 60%.

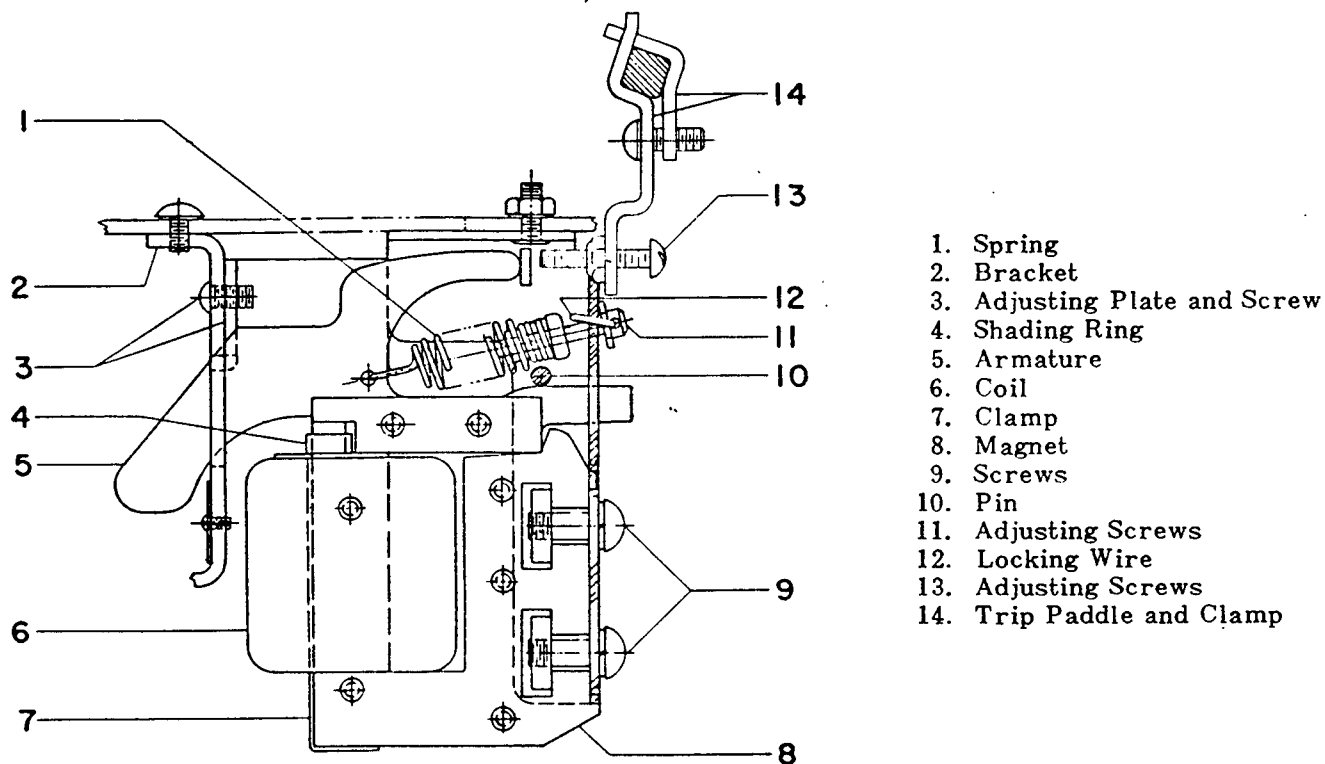

Figure 22 Static Time-Delay Undervoltage Tripping Device

The undervoltage device coil circuit is continuously rated and will remain picked up as long as the voltage remains above the predetermined drop out voltage. The time delay is field adjustable between 1 and 5 seconds. It is factory set at the minimum setting, and once the time delay is established, it is consistent.

No more than one undervoltage device should be connected to a static time delay box.

The Static Time Delay Undervoltage can also be furnished in conjunction with the thermotector control package, as shown on wiring diagram 0102C-3699 (Fig. 24). Overheating of the motor windings causes the thermotector, imbedded in the motor windings, to open and allow the 'Z' relay of the control box to instantaneously trip the breaker through a normally closed 'Z' contact in series with the undervoltage device mounted on the breaker.

WARNING

DO NOT USE BELL SET TO CHECK CONTINUITY OF BRIDGE CIRCUIT IN STATIC TIME DELAY BOX. ONLY A VOLT-OHM METER OR VACUUM TUBE VOLT METER SHOULD BE USED.

In the event the device fails to pick-up, the following checks are recommended to determine whether the

magnetic device on the breaker or the static delay unit is the faulty component.

- A. Check input voltages across terminals 1 & 2 on static box. These voltages should be as follows:
 1. Device 177L316 G-12-208 or 230 volts A.C.
 2. Device 177L316 G-14-125 volts D.C.
 3. Device 177L316 G-15-250 volts D.C.
- B. Check output voltages on terminals 4 & 5 (Fig. 23) with the under voltage device connected. The approximate voltages are as follows:
 1. 208 Volt A.C. 177L316 G-12- 110 Volts D.C.
230 Volt A.C. 177L316G-12-120 D.C. Volts D.C.
 2. 125 Volt D.C. 177L316G-14 50 Volts D.C.
 3. 250 Volt D.C. 177L316G-15- 100 Volts D.C.
- C. The resistance of the undervoltage coils is as follows:
 1. 6275081 G-59 - 1830 Ohms.
 2. 6275081 G-61 - 440 Ohms.

REPLACEMENT (REFER TO FIG. 22)

1. Disconnect coil leads.

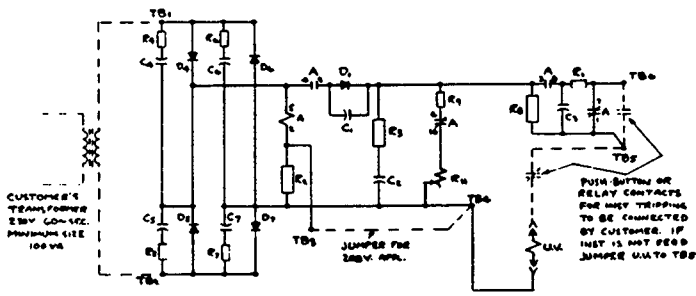

- A - 250V. DC. RELAY
- C₁, C₂, C₃, C₄, C₅, C₆ - 10μf ±10% 600WVDC.
- C₇ - 550μf 350WVDC.
- C₈ - 1000μf 200WVDC.
- D₁, D₂, D₃, D₄, D₅ - 1N360 - 600 mA @ 30°C
- R₁ - 15 A 3W ±5%
- R₂ - 1500 A 3W ±5%
- R₃ - 75 A 5W ±5%
- R₄, R₅, R₆, R₇ - 10 A 1/2 W
- R₈ - 1-20 A 20W ±5%
- R₉ - 0.15, 0.08 A 15W
- R₁₀ - 50 A 3W ±5%

Figure 23 Static Time Delay Undervoltage Wiring Diagram

2. Remove mounting screws and remove device.
3. Install new device in reverse order.

Coil (6)

1. Disconnect leads to coil.
2. Remove two screws (9).
3. Remove magnet and coil assembly.
4. Straighten laminations around shading ring (4).
5. Remove shading ring and straighten lower end of coil clamp (7).
6. Remove coil. Install new coil in reverse order.

INSTANTANEOUS UNDER-VOLTAGE TRIPPING DEVICE

The instantaneous undervoltage device is mounted in the same location and manner as the static time-delay device and its construction is similar.

The adjustments and replacement of this device are the same as those described above for the static time-delay undervoltage device.

UNDERVOLTAGE LOCKOUT DEVICE (FIG. 25)

The undervoltage lockout device holds an open breaker trip-free when the coil of the device is de-energized. When the breaker is in the closed position, linkage operated by the breaker mechanism cam positions itself to mechanically hold the undervoltage device armature in the closed air gap position.

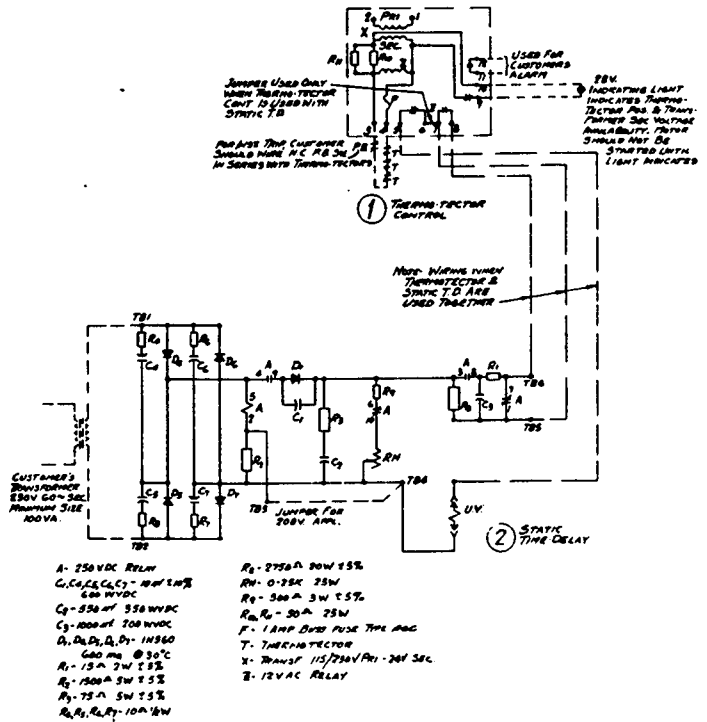

- A - 250 VDC RELAY
- C₁, C₂, C₃, C₄, C₅ - 10μf ±10% 600 WVDC
- C₆ - 550 μf 350 WVDC
- C₇ - 1000 μf 200 WVDC
- D₁, D₂, D₃, D₄, D₅ - 1N360 600 mA @ 30°C
- R₁ - 15 A 3W ±5%
- R₂ - 1500 A 3W ±5%
- R₃ - 75 A 5W ±5%
- R₄, R₅, R₆, R₇ - 10 A 1/2 W
- R₈ - 15 A 3W ±5%
- R₉ - 500 A 3W ±5%
- R₁₀ - 20 A 25W
- F - 1 AMP 5000 FUSE TIME MISC
- T - THERMO-TECTEUR
- X - TRANSF. 115/250V/100 - 200 SEC.
- Z - 12 VAC RELAY

Figure 24 Thermotector Wiring Diagram

tion to prevent tripping the breaker in the event the undervoltage device coil is de-energized. This feature when used in conjunction with normally-closed auxiliary contacts of an alternate breaker presents a convenient method of mechanically interlocking two or more breakers to assure that no two breakers may be closed at the same time.

The undervoltage lockout device is mounted on the right side of the mechanism frame (7) (looking from the front). This device is identical to the standard instantaneous undervoltage trip device, with the addition of the lockout feature. The lockout feature consists of arm (2), lever (3), and spring (6). The lockout linkage is activated by the movement of the mechanism cam (1). When the breaker is closed, the undervoltage device is defeated by the lever (3) holding the armature (4) in the closed air gap position. When the breaker opens, the mechanism cam moves down, allowing spring (6) to rotate arm (2) clockwise which causes lever (3) to rotate counter-clockwise to release armature (4) allowing the undervoltage device to operate normally.

DIRECT ACTING TRIPPING DEVICE EC-1B (FIG. 26) (USED ON AK-2-75 AND AK-2-100)

The type EC-1B overcurrent tripping device is a direct-acting device that causes the power circuit breaker with which it is associated to open within a predetermined time range which depends upon the magnitude of the current overload. The EC-1B

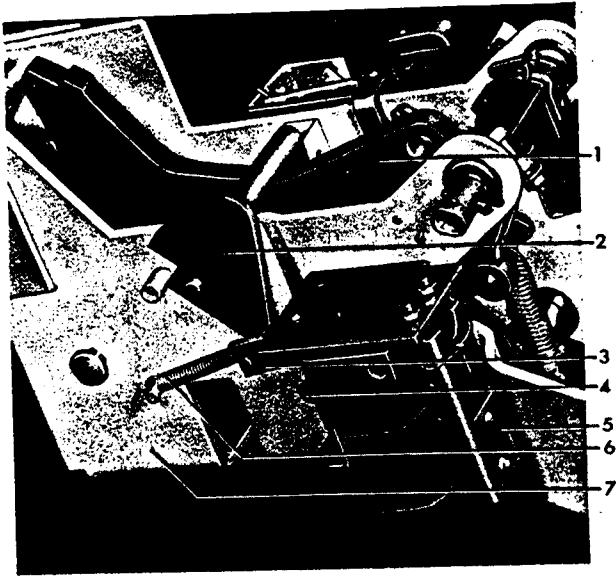

UNDERVOLTAGE LOCKOUT DEVICE
TYPE AK-50, 75 & 100

1. Mechanism Cam
2. Undervoltage Lockout Arm
3. Undervoltage Lockout Lever
4. Undervoltage Device Armature
5. Undervoltage Device
6. Undervoltage Lockout Spring
7. Mechanism Frame

Figure 25 Right Side View of Mechanism Frame
Breaker Shown in Open Position

tripping device can be constructed to supply a variety of different types of time-current characteristics, either alone or in combination. These are long time delay, short time delay, and instantaneous, and they are identified respectively by numbers 1, 2 and 3. Characteristics are further broken down within each of the first two of these general classifications into maximum, intermediate and minimum values of the time delay period. These are coded respectively as AA, BB and CC. Time and current relationships for the various device characteristics are given by curve drawing 289B198.

The EC-1B is adjustable on high-set instantaneous tripping. The adjustable setting mechanism of the EC-1B is shown in Fig. 26.

Low-set instantaneous tripping is adjustable from 80 percent to 250 percent of the continuous current rating of the device. Whenever this is used, it is the only characteristic of the device. Instantaneous tripping used in conjunction with any other characteristic is always high-set.

When armature (1 or 22) closes against the magnet (11), motion is transmitted through the mechanism linkage, rotating tripping link (8) so that

connecting rod (10) is pulled towards the rear of the breaker. By means of trip paddle (14) results in the displacement of the breaker mechanism trip latch which causes the breaker to trip open. Long and short time delay tripping is achieved through separate timing devices as described below:

SHORT TIME-DELAY TRIPPING

(Fig. 26)

The short time delay armature (1) is restrained by a calibration spring (6). If the force tending to close the armature against the magnet (11) is great enough to overcome the spring force, the speed of movement is governed by the mechanical escapement mechanism consisting of parts (2), (3), (4) and (5).

LONG TIME-DELAY TRIPPING (Fig. 26)

The long time delay armature (22) is restrained by the long time delay calibration spring (15). After the magnetic force produced by the overcurrent condition overcomes this restraint, the velocity of the armature movement is governed by the flow of oil through an orifice in the piston of the dashpot (17). The time required to displace the piston is inversely proportional to the force tending to close the magnetic circuit.

INSTANTANEOUS TRIPPING (Fig. 26)

High-set, Non-adjustable

When an overcurrent is of the magnitude of instantaneous trip setting, the magnetic force generated is great enough to extend the instantaneous spring (21), tripping the breaker instantly. If the overcurrent is below this value, the heavy instantaneous spring acts as a link, transmitting the force to the other control elements. If the device has only the instantaneous characteristic, the front end of spring (21) is hooked onto a pin fastened on the frame.

High-set, Adjustable - EC-1B

Adjustable instantaneous tripping is accomplished by varying the amount of tensile force on the high-set instantaneous spring (21). When a magnetic force greater than the restraining spring force is produced by an over-current condition, the armature (22) is pulled upward against the magnet (24), thus tripping the breaker by the movement of the connecting rod (13) against the trip paddle (14).

The pickup value of the device may have one of the following ranges: 4 to 9, 6 to 12, or 9 to 15 times coil rating. Three calibration marks will appear on the calibration scale (18) and the value of these calibration marks will be indicated by stampings on the scale as follows: (4X - 6.5X - 9X) or (6X - 9X - 12X) or (9X - 12X - 15X), depending on the desired range. To set the device at a particular pickup value, loosen the clamping nut (20) and the index pointer on the calibration washer (19) to a position which lines up horizontally with the desired pickup value on the calibration scale (18).

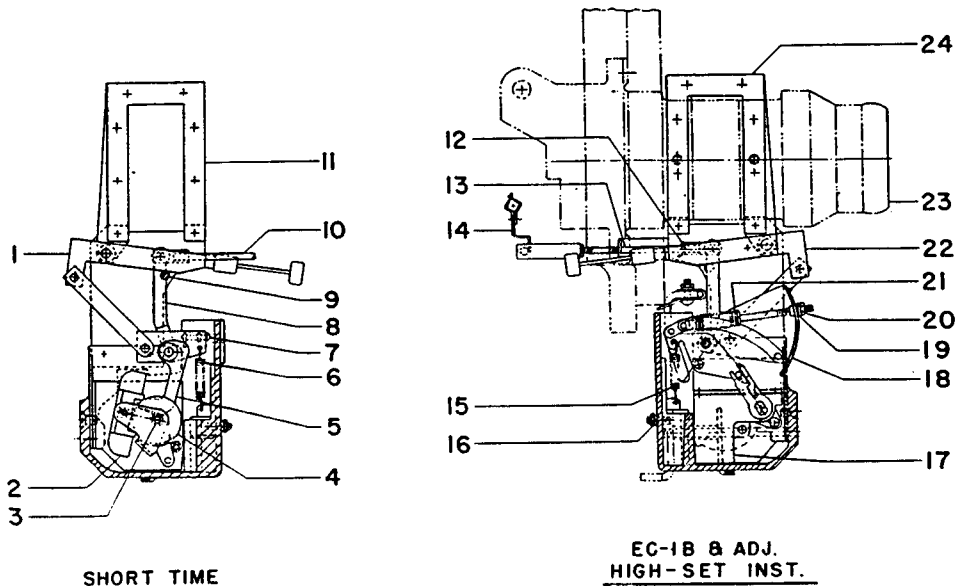

- | | | |
|------------------------------|-------------------------------|------------------------------|
| 1. S.T.D. Armature | 9. Air Gap Adj. | 17. Dashpot |
| 2. Pallet | 10. Connecting Rod | 18. Calibration Scale |
| 3. Pinion | 11. Magnet | 19. Calibration Washer |
| 4. Escape Wheel | 12. Lock Nut | 20. Clamping Nut |
| 5. Driving Segment | 13. Connecting Rod | 21. Inst. Calibration Spring |
| 6. S.T.D. Calibration Spring | 14. Trip Paddle | 22. L.T.D. Armature |
| 7. S.T.D. Trip Adj. | 15. L.T.D. Calibration Spring | 23. Stud |
| 8. Trip Link | 16. Calibration Clamp Nut | 24. Magnet |

Figure 26 Direct-Acting Tripping Device EC-1B

Low-set, Adjustable

If the characteristic of the device is low-set, adjustable instantaneous, a link is installed in place of spring (21) and the instantaneous calibration spring is located where spring (15) is shown in Fig. 26. Dashpot (17) is omitted from assembly.

REPLACEMENT (Fig. 26)

1. Disconnect trip paddle (14) and connecting rod (10) by taking out cotter pin and removing coupling pin.
2. Remove clamp by loosening locking nut and unscrewing slotted stud.
3. Remove stud (23).
4. Remove two screws fastening magnet (11) to lower stud.
5. Device is now free of breaker. Reassembly is accomplished by reversing the procedure.

When reassembling the magnet to the lower stud, be sure to replace any spacing washers in the same location in which they were found during disassembly. If this is not done, misalignment and consequent malfunction may result.

ADJUSTMENTS (Fig. 26)

Before the EC-1B overcurrent device is calibrated at the factory, the air gaps between magnet (11) and armatures (1 and 22) are set. These gaps are measured at their widest point, between the front edge of the armature and magnet. The gap for the short time delay armature is $17/64$ in., and for the long time delay armature is $17/64$ in. Both have a plus and minus tolerance of $1/64$ in.

The air gap setting is a factory adjustment and is not to be attempted in the field. If any change occurs, the calibration of the device will not be true. If any calibration difficulties are experienced, they may be due to the fact that the air gap setting has been altered by rough handling or shipment damage. If a check of the air gap measurement reveals that the setting is beyond the tolerance, the device should be returned to the factory for recalibration.

The adjustment screw (7) is provided so that the short-time mechanism will pick up the trip link (8) at the same point at which it is picked up by the long-time mechanism. This may be checked before the device is mounted by pulling forward on the connecting link (10) and checking visually to see that trip link (8) contacts both the set pin in the long time linkage and the end of adjustment screw (7).

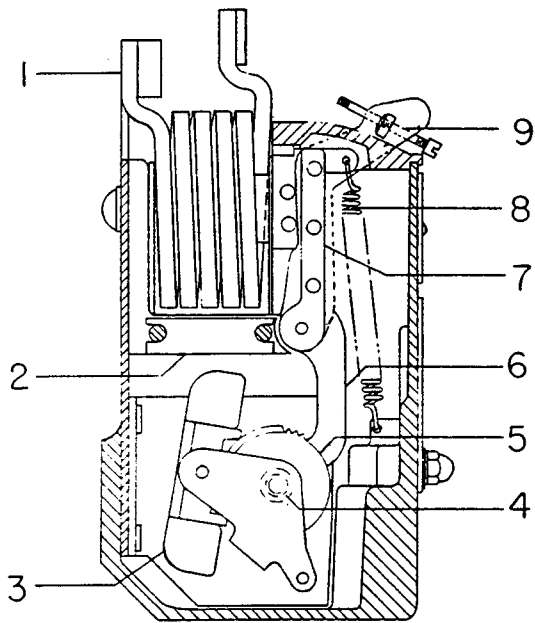

Left Side View Showing Short Time Delay Mechanism

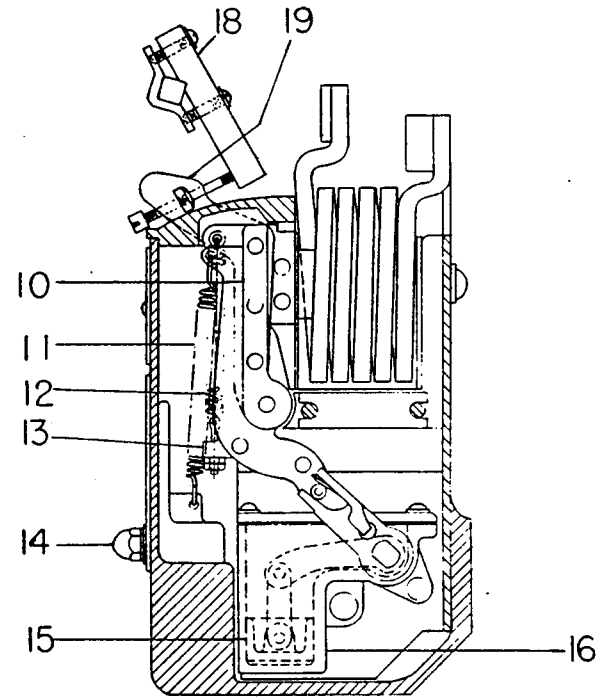

Right Side View Showing Long Time Delay Mechanism

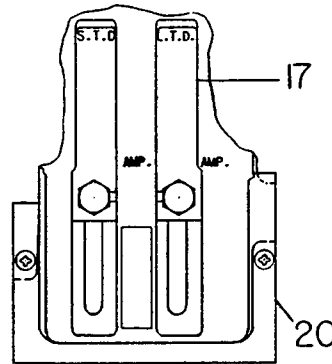

Front View Showing Mounting Bracket

- | | | |
|--------------------|---|---------------------------|
| 1. Series Coil | 8. S.T.D. Calibration Spring | 14. Calibration Clamp Nut |
| 2. Magnet | 9. Trip Paddle Adjusting Screw | 15. Plunger |
| 3. Pallet | 10. L.T.D. Armature | 16. Cylinder |
| 4. Pinion | 11. L.T.D. and Low-Set Inst. Calibration Spring | 17. Calibration Plate |
| 5. Escape Wheel | 12. Inst. Trip Spring (High Set) | 18. Trip Paddle |
| 6. Driving Segment | 13. Spring Holder | 19. Trip Arm |
| 7. S.T.D. Armature | | 20. Clamping Bracket |

Figure 27 Series Overcurrent Tripping Device EC-1 (AK-50 only)

After the device is mounted on the breaker, a final adjustment that must be made is the length of the connecting rod (10). This is made by varying the amount of thread engagement between the connecting rod and the insulated coupling which ties onto the trip paddle (14). The approximate distance between the pivot centers on the ends of the connecting rod assembly is six inches. The correct exact distance is that which will just cause tripping of the breaker when the armature is closed

to a point 1/32 in. short of contact with the magnet. A step-by-step procedure for making this adjustment follows.

1. Before mounting the trip device, set the center distance between the pivot centers of the connecting rod at six inches.
2. Mount the device as described under replacement and insert the pin which couples the connecting rod and the trip paddle.

3. Close the breaker and insert a feeler gage 1/32 in. thick between the armature and magnet. This should be done from the rear of the breaker. The feeler gage should be no wider than 1/2 in. and at least 4 inches long.
4. Close the armature against the gage and magnet.
5. If the breaker does not trip, form paddle 14 to obtain positive trip.
6. Check visually to make sure that the connecting rod does not restrict the engagement of the breaker trip latch when the breaker mechanism resets. It should always be possible to adjust its length to a point where resetting is not interfered with and yet positive tripping by the overcurrent device is achieved.

SERIES OVERCURRENT TRIPPING DEVICE EC-1 (FIG. 27)

Each series overcurrent tripping device is enclosed in a molded case and mounted by three screws and a bracket to the lower part of the pole unit base.

The device can be provided with the same tripping combinations as the EC-1 direct acting device.

SHORT TIME-DELAY TRIPPING (Fig. 27)

The armature (7) is restrained by calibrating spring (8). After the magnetic force produced by an overcurrent condition overcomes this restraining force, the armature movement is further retarded by an escapement mechanism which produces an inverse time delay characteristic. The mechanism is shown in Fig. 27.

LONG TIME-DELAY TRIPPING (Fig. 27)

The armature (10) is restrained by the calibration spring (11). After the magnetic force produced by an overcurrent condition overcomes this restraining force, the armature movement is further retarded by the flow of silicone oil in a dashpot, which produces an inverse time delay characteristic. The mechanism is shown on Fig. 27.

INSTANTANEOUS TRIPPING (Fig. 27)

- (a) Adjustable instantaneous tripping takes place after the magnetic force produced by an overcurrent condition, overcomes the restraining force of the calibration spring which can be adjusted by the calibration clamp nut (14).
- (b) Non-adjustable instantaneous tripping takes place after the magnetic force produced by an overcurrent condition overcomes the restraining force of a non-adjustable spring.

ADJUSTMENTS (Fig. 27)

Calibration clamping nuts (14) are used to set the desired pickup for the adjustable elements.

To adjust for approximately 1/32 in. over-travel of trip arm (19) after tripping:

1. Check trip latch engagement. See ADJUSTMENTS - OPERATING MECHANISM.
2. Loosen the locknut and turn the adjusting screw (9) on the trip arm (19). The screw should not touch the trip paddle when the breaker is 'open'. Adjust positive trip same as EC-2A (see series overcurrent tripping device EC-2, EC-2A, AK-50).
3. Tighten the adjusting screw locknut on the trip arm.

NOTE

In lieu of locknuts, some devices are equipped with self-locking nylon insert nuts.

REPLACEMENT (Fig. 27)

1. Remove front frame (see SEPARATION OF FRONT AND REAR FRAMES).
2. Remove the bolts holding the coil to the lower stud.
3. Remove bracket and mounting screws.
4. Before installing a new device, check the travel of the trip arm with a rod or wire and push the armature solidly against the magnet (see Fig. 28). The trip arm should travel at least 5/32-in.
5. Replace new device in reverse order.

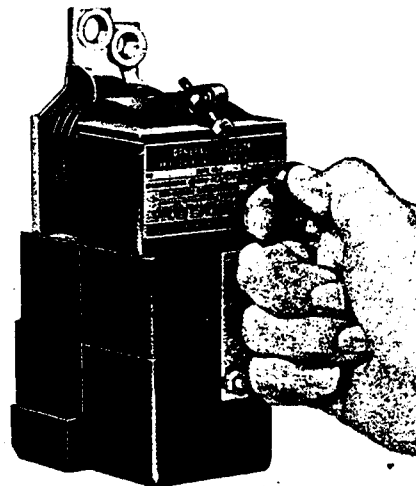

Figure 28 Checking Travel Distance of Series Overcurrent Tripping Device

6. Adjust device as described above.

NOTE

Component parts of any overcurrent tripping devices are not replaceable. It will be necessary to install a new device when parts are worn or damaged.

**SERIES OVERCURRENT TRIPPING DEVICE
EC-2, EC-2A, AK-50**

The Type EC-2, EC-2A, (see Fig. 29) overcurrent tripping device is available in three forms:

1. Dual overcurrent trip, with long-time delay and high-set instantaneous tripping.

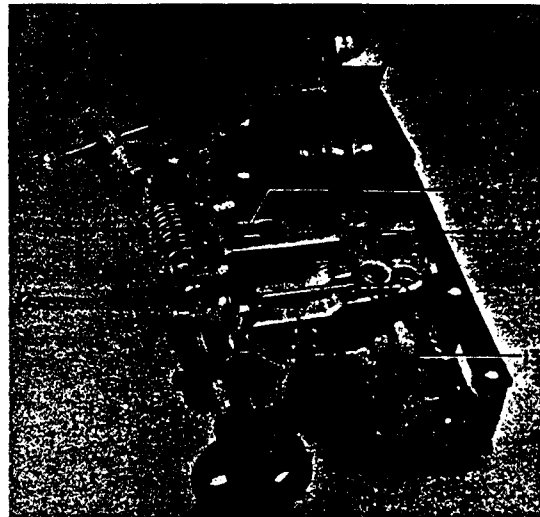
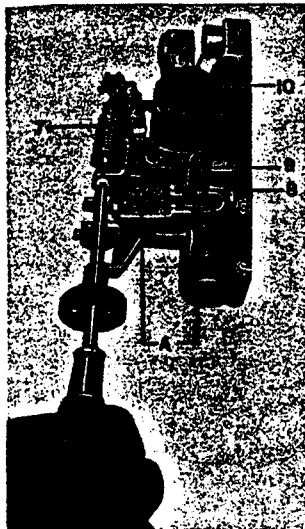
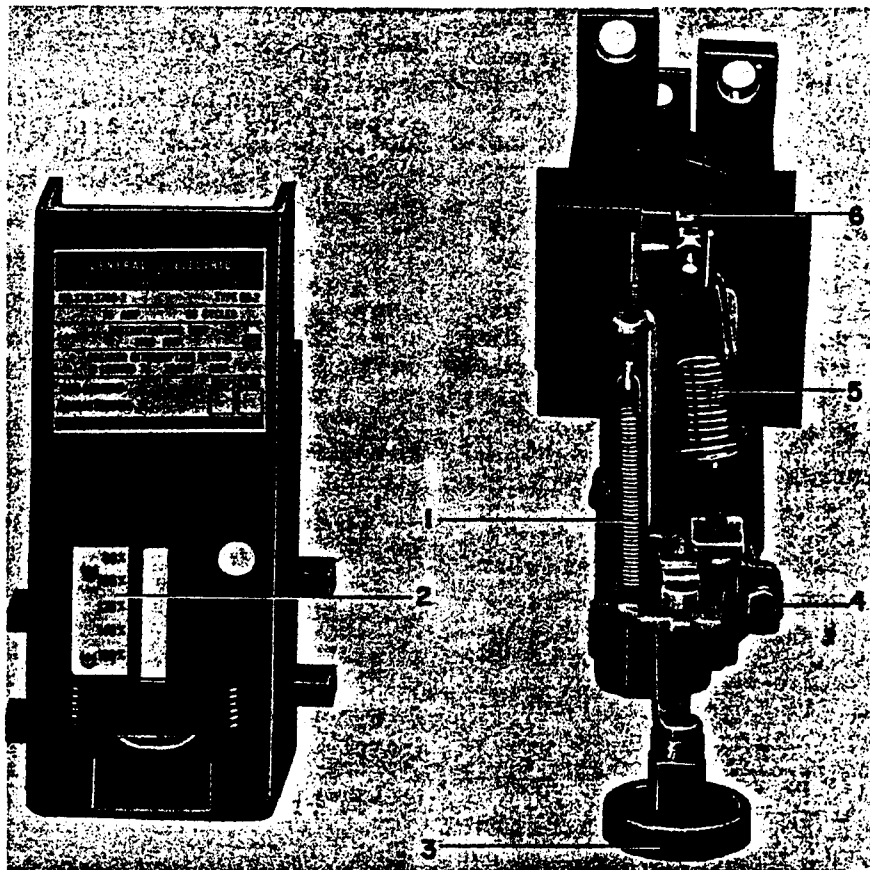

Figure 29 Overcurrent Tripping Device EC-2

2. Low-set instantaneous tripping.

3. High-set instantaneous tripping.

The dual trip has adjustable long-time and instantaneous pick-up settings and adjustable time settings. Both forms of instantaneous trip have adjustable pick-up settings.

LONG TIME-DELAY AND HIGH-SET INSTANTANEOUS TRIPPING (Fig. 29)

By means of the adjustment knob (3), which can be manipulated by hand, the current pick-up point can be varied from 80 to 160 percent of the series coil rating. The indicator and a calibration plate (2) on the front of the case provide a means of indicating the pick-up point setting in terms of percentage of coil rating. The calibration plate is indexed at percentage settings of 80, 100, 120, 140, and 160.

As in the case of the EC-1 over-current trip, the long-time delay tripping feature can be supplied with any one of three time-current characteristics which correspond to the NEMA standards maximum, intermediate and minimum long-time delay operating bands. These are identified as 1A, 1B and 1C characteristics, respectively. Approximate tripping time for each of these, in the same order, are 30, 15, and 5 seconds at 600 percent of the pick-up value of current. (See time-current characteristic curves, Fig. 42).

The tripping time may be varied within the limits shown on the characteristic curves by turning the time adjustment screw (4). Turning in a clockwise direction increases the tripping time; counterclockwise motion decreases it. The dashpot arm (8) is indexed at four points, MIN-1/3-2/3-MAX, as indicated in Fig. 30. When the index mark on the connecting link (9) lines up with a mark on the dashpot arm, the approximate tripping time as shown by the characteristic curve is indicated. The 1A and 1B characteristic devices are shipped with this setting at the 2/3 mark and the 1C characteristic at the 1/3 mark. The standard characteristic curves are plotted at these same settings.

Time values are inversely proportional to the effective length of the dashpot arm. Therefore, the linkage setting that gives the shortest time value is the one at which dimension 'A', Fig. 29, is greatest. The time adjustment screw (4) may be turned by inserting a Phillips head screwdriver through the hole in the front of the case. If it is desired to relate the linkage setting to the index marks on the linkage it will be necessary to remove the case. This may be done by removing the two mounting screws, one on each side of the case, which may be taken off without disturbing the trip unit itself.

If the breaker is provided with a shunt trip or undervoltage device, the EC-2, EC-2A, case on

the center pole must be taken off first before the cases on the outer poles can be removed.

INSTANTANEOUS LOW-SET TRIPPING (Fig. 29)

The low-set instantaneous pick-up point may be varied by the adjustment knob (3). The calibration in this case usually ranges from 80 percent to 250 percent of the series coil rating, with the calibration plate indexed at values of 80, 100, 150, 200, and 250 percent of the rating.

INSTANTANEOUS HIGH-SET TRIPPING (Fig. 29)

The high-set instantaneous pick-up value may have one of the following three ranges: 4 to 9 times coil rating; 6 to 12 times coil rating or 9 to 15 times coil rating. The pick-up setting may be varied by turning the instantaneous pick-up adjusting screw (12).

Three calibration marks (15) will appear on the operating arm (14) and the value of these calibration marks will be indicated by stampings on the arm as follows: (4X - 6.5X - 9X) or (6X - 9X - 12X) or (9X - 12X - 15X).

At the factory, the pick-up point has been set at the nameplate value of the instantaneous trip current. (Usually expressed in times the ampere rating of the trip coil). The variation in pick-up setting is accomplished by varying the tensile force on the instantaneous spring (5). Turning the adjustment screw changes the position of the movable nut (11) on the screw. The spring is anchored to this movable nut so that when the position of the nut is changed, there is a corresponding change in the spring load. As the spring is tightened, the pick-up point is increased.

The top edge of the movable nut (11) serves as an index pointer and should be lined up with the center of the desired calibration mark (15) to obtain the proper instantaneous trip setting.

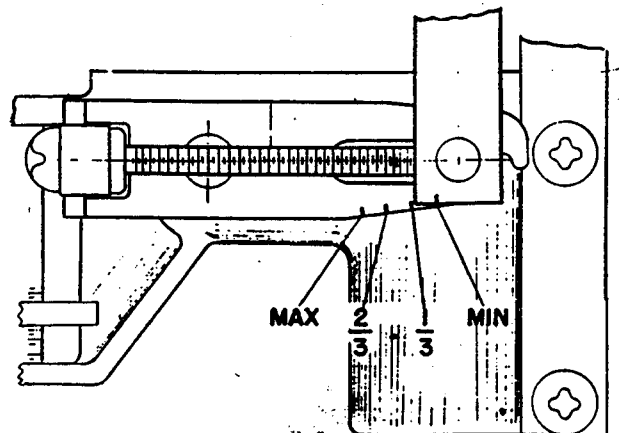

Figure 30 Time-Adjustment Indexing

The trip screw (6) on the end of the armature (7) should be set so that it does not contact the trip paddle on the trip shaft until the air gap between armature and pole piece is reduced to 3/32 in. or less, measured at the rivet in the pole piece. Also, the armature must have a minimum of 1/32 in. of travel beyond the point in its motion at which the breaker is tripped.

Replacement of the EC-2, EC-2A device is accomplished by the same procedure described for the EC-1 series trip device; however, in some cases, when replacing an EC-1 device with an EC-2, EC-2A it will be necessary to replace the trip paddles on the trip shaft with ones which are slightly longer. When required these will be provided with the replacement trip units.

NOTE

Pickup settings on the cover of the EC-2, EC-2A device are calibrated for the specific device. When replacing covers, replace on associated device.

REVERSE CURRENT TRIPPING DEVICE AK-50 ONLY (FIG. 31)

The device is enclosed in a molded case and is mounted on the right pole base similar to the series overcurrent tripping device.

The reverse current tripping device (see Fig. 28) consists of a series coil (2) with an iron core mounted between two pole pieces (9), also a potential coil (7) connected across a constant source of voltage and mounted around a rotary-type armature (10). Calibration spring (6) determines the armature pick-up when a reversal of current occurs.

As long as the flow of current through the breaker is in the normal direction, the magnetic flux of the series coil and the magnetic flux of the potential coil produce a torque which tends to rotate the armature counterclockwise. The calibration spring also tends to rotate the armature in the same direction. This torque causes the armature to rest against the stop screw (12) attached to a bearing plate on the right side of the device.

If the current through the series coil (2) is reversed, the armature (10) tends to move in the clockwise direction against the restraint of the calibration spring (6). When the current reversal exceeds the calibration setting, the armature revolves clockwise causing the trip rod (3) to move upward engaging the trip paddle (1), thereby tripping the breaker.

ADJUSTMENTS (Fig. 31)

The only adjustment to be made on the reverse current device is to make sure that the trip rod has a minimum overtravel of 1/32 in. beyond the point of tripping the breaker. This adjustment should

have to be made only when an old device is being replaced by a new one.

The new device will be factory adjusted so that the top end of the trip rod (3) will extend 1/2 in. above the top of the device case, and no additional adjustments of the trip rod should be required. To obtain the proper 1/32 in. over-travel, close the breaker and proceed as follows:

1. Loosen the locking nut (2B).
2. Manually lift the trip rod and vary the position of the adjusting nut (2A), thus establishing the position of the adjusting nut where the breaker is just tripped.

WARNING

BE SURE TO KEEP CLEAR OF MOVING BREAKER PARTS WHEN TRIPPING THE BREAKER.

3. With this position of the adjusting nut established, advance the adjusting nut upward one and one-half turns.
4. Tighten the locking nut and the minimum 1/32-in. overtravel of the trip rod should be obtained.

REPLACEMENT (Fig. 31)

After removing the wiring for the potential coil the reverse current device can be removed and replaced by following the procedure outlined for replacing the series overcurrent device. For wiring, see Fig. 31.

POWER SENSOR TRIP

GENERAL DESCRIPTION

All AK-3 Type Air Circuit Breakers contain Power Sensor Overcurrent Trip Devices. The Power Sensor Trip functions with solid state components with the exception of the Solenoid Trip which is used to trip the breaker on signal from the Power Sensor Unit. The Power Sensor Overcurrent Trip Device consists of four major components.

1. The magnetic coils around the breaker conductors (Fig. 32 & 33).
2. The Power Supply which provides both the tripping energy and the comparison basis for overcurrent detection (Fig. 34).
3. The Power Sensor Unit with the various pick-up settings and time delay selection taps (Fig. 35).
4. The trip solenoid which physically trips the breaker (Fig. 36).

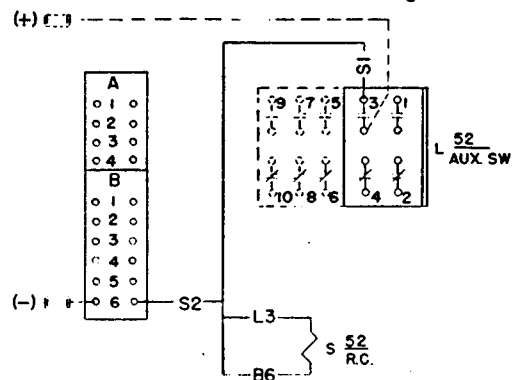
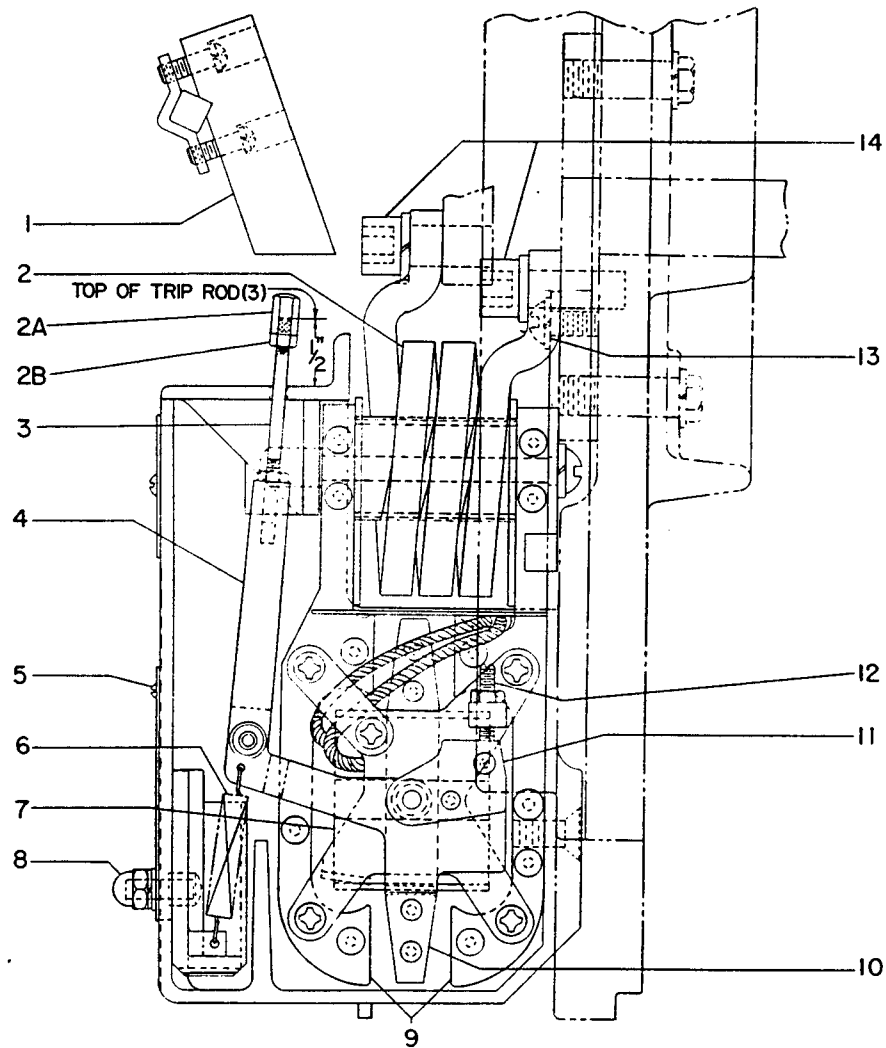

- | | |
|--------------------------|--------------------|
| 1. Trip Paddle | 7. Potential Coil |
| 2. Series Coil | 8. Calibration Nut |
| 2A. Adjusting Nut | 9. Pole Pieces |
| 2B. Locking Nut | 10. Armature |
| 3. Trip Rod | 11. Counter Weight |
| 4. Trip Crank | 12. Stop Screw |
| 5. Setting Sealing Screw | 13. Mounting Screw |
| 6. Calibration Spring | 14. Screw |

Figure 31 Reverse Current Tripping Device

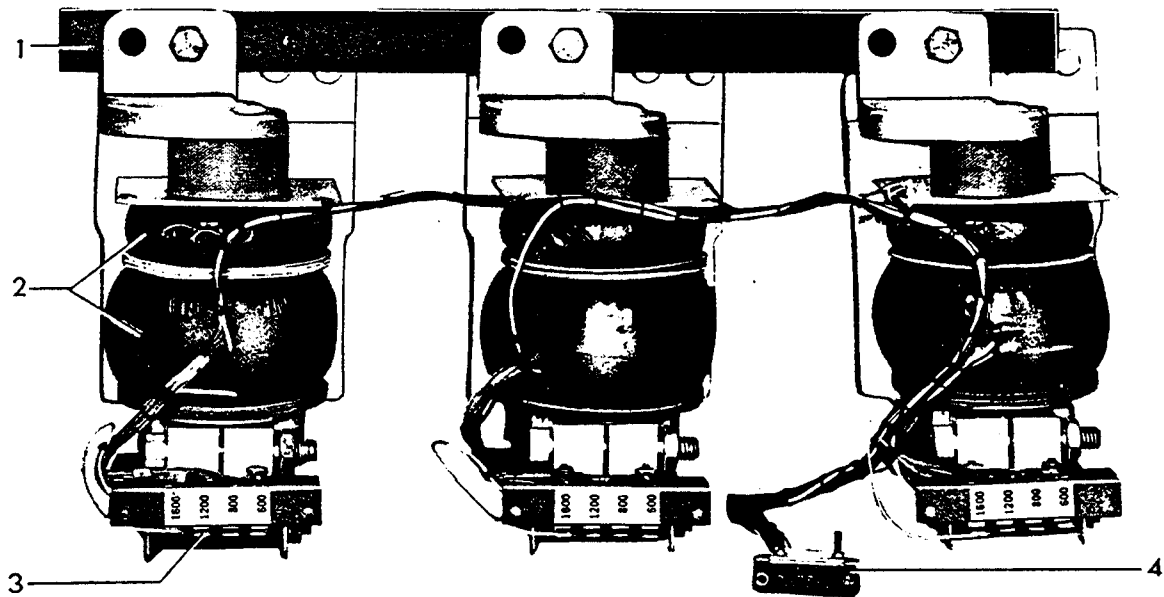

- | | |
|--|--|
| <p>1. Carrying Fixture
2. Power Supply Coil, Current Sensor Coil</p> | <p>3. Transformer Taps (In Amperes)
4. Disconnect Plug</p> |
|--|--|

Figure 32 Magnetic Coil Assembly For AK-3-50 Breakers

In addition to the phase overcurrent protection, a ground fault sensing feature may be provided. The Ground Sensing Device works on the principle that the instantaneous value of current flowing in the three conductors (or in four conductors on four wire systems) must add to zero unless ground current is flowing. Therefore, if the electrical system is a four wire wye system with the neutral grounded at the transformer, the fourth sensing coil Fig. 38 must be included on the neutral conductor with its secondary combined with the secondaries of the three phase sensors which are mounted on the breaker. On Draw-out breakers the output of the external neutral sensor must enter the breaker by a control disconnect which is mounted low and on the centerline on the back of the breaker. Refer to Fig. 37 for Power Sensor Cabling Diagram.

MAINTENANCE

When mal-functioning of the Power Sensor Trip is indicated, the trouble should be traced to one or more of these four components involved, and that component should be replaced as a unit. The following steps should be taken to detect a mal-functioning unit.

NOTE

No adjustment to the taps controlling pick-up should be made with the breaker carrying current.

In the event the Power Sensor Device must be made non-operative to allow the breaker to continue carrying current without overcurrent protection, it is recommended that the leads to the

tripping solenoid be removed to completely eliminate the possibility of the breaker tripping. Do not close breaker with power on the main contact while the disconnect plug to the magnetic coils is disconnected.

1. Check for the existence of overcurrent or ground fault conditions that may be causing the breaker to trip as a proper response to these normal circuit conditions.
2. The possibility of the breaker being trip free by mechanical interferences along the trip shaft or inadvertent shunt trip operations should be positively eliminated before investigating the Power Sensor. Successful operations in the test position should be obtained before proceeding with the Power Sensor trouble shooting.
3. A PST-1 Power Sensor Test Kit must be available (Fig. 39). Check the Power Sensor Unit for correct function for each pick-up setting and one point on each time delay characteristic. Then check for the correct operation of each phase of the Power Supply Unit. This procedure is described in the instruction manual (GEK-7301) for the PST-1 Test Kit. If the test results for this test do not deviate more than 10% from the published curves, proceed to step 4. If the deviation is more than 10% contact the factory for possible replacement of the Power Sensor Unit.
4. If the breaker is equipped with ground fault protection, determine whether the false tripping is the result of falsely answering an over-

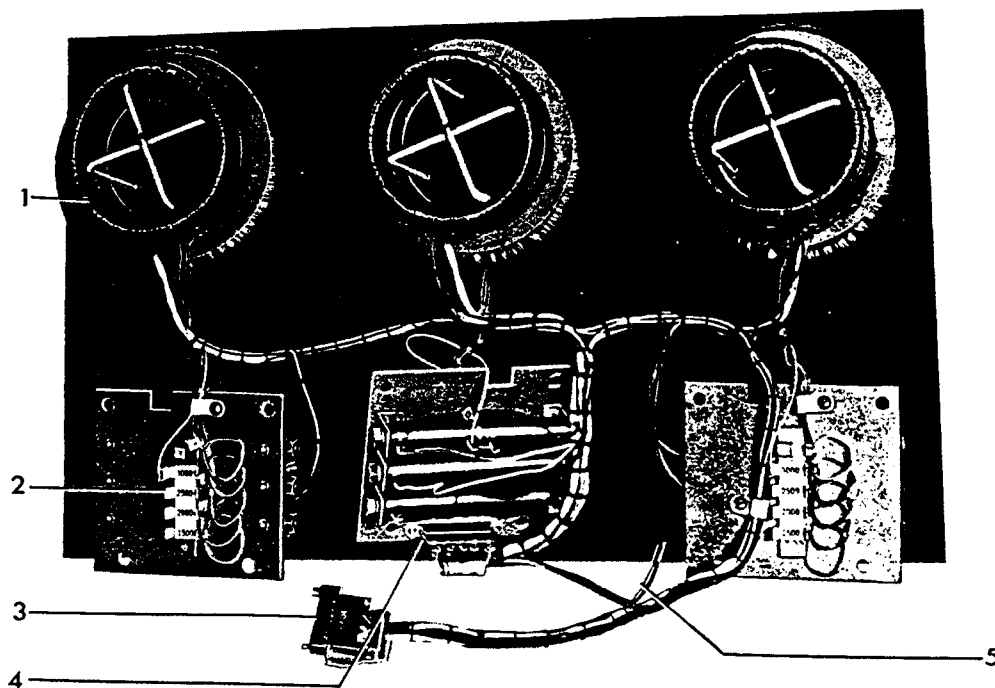

1. Power Sensor Coil Assembly
 2. Transformer Taps in Ampere
 3. Disconnect Plug
 4. Terminal Board
 5. External Ground Sensor Lead

Figure 33 Magnetic Coil Assembly For AK-3 75, 100 Breakers (Only)
 (Mounted on Assembly Fixture)

current trip or a ground trip signal. This may be determined by temporarily eliminating the ground trip signal by shorting out the ground signal points 1 and 5 at the ground signal terminal board on the back frame of the breaker. Terminals 1 and 5 can be identified by the 0.15UF capacitor connected between them. (See drawing 138B2454) (Fig. 40). With the breaker restored to service and with the ground fault detector deactivated, establish whether there is false tripping due to overcurrent.

FALSE TRIPPING CAUSED BY FAULTY GROUND FAULT DETECTION

If the breaker is equipped for four wire service (fourth C.T. remotely (Fig. 38) it is important that the shielding be effective by having continuity from the disconnect plug at the Power Sensor Unit to the external C.T. and further that this shield be isolated from the signal conductors. It is also important that continuity exists through the ground signal circuit. Check these conditions as follows; referring to Fig. 40.

1. Remove connection plug at Power Sensor Unit and check continuity between A and C (Signal). Letters are located on end of plug.
2. Check to be sure no continuity exists between R and C.

3. Temporarily connect jumper from shield to either terminal at remote C.T. and check to assure the shield is continuous from Power Sensor Plug to remote C.T. by checking for continuity between R and A. If continuity does not now exist, shield is not continuous and the point of discontinuity must be found. Check the control disconnect as the possible point of discontinuity. Remove jumper at remote C.T. after shield continuity is established.

Note the polarity marks on the ground sensors. Be sure the external ground C.T. senses the neutral current associated with the particular breaker load current and that polarity marks are in accordance with Fig. 40. If the breaker bottom studs connect to the source, the external C.T. must also have its polarity mark toward the source.

TESTING MAGNETIC COILS

After the PST-1 Test Kit has been used to determine the adequacy of performance of the Power Sensor Unit and the Power Supply Unit, it may be advisable or required to test the magnetic coils by the use of a Hi-current - Low voltage type test set. In this event only one test per phase need be made. This test should be made at some convenient multiple of pick-up setting such as 3X current setting for comparison with published time-current curves.

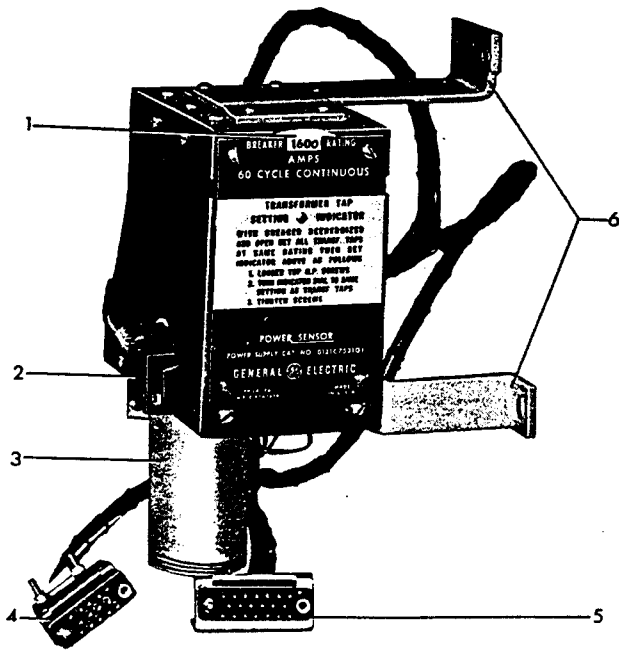

1. Indicator
2. Terminal Block
3. Capacitor
4. Female Disconnect Plug
5. Male Disconnect Plug
6. Mounting Brackets

Figure 34 Power Supply

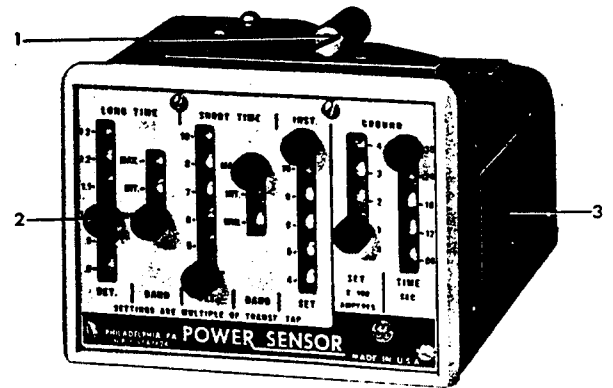

1. Mounting Screw
2. Captive Thumb Screw
3. Name Plate

Figure 35 Power Sensor Unit

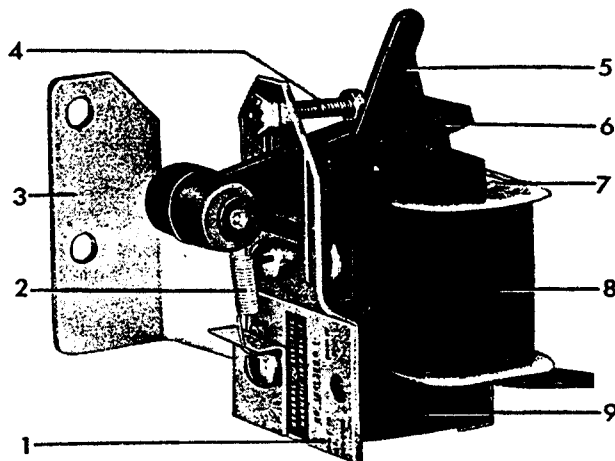

- | | | |
|---------------------|--------------------|-----------|
| 1. Name Plate | 4. Adjusting Screw | 7. Clamp |
| 2. Spring | 5. Trip Arm | 8. Coil |
| 3. Mounting Bracket | 6. Armature | 9. Magnet |

Figure 36 Magnet Trip Device

In the event the breaker is equipped with ground sensor, the ground sensor will cause tripping on single pole testing unless the signal is shorted to the terminal board Fig. (40). Short point 1 and 5 during overcurrent test.

The above considerations should indicate which of the four major components is faulty and in need of replacement.

REPLACEMENT OF POWER SENSOR COMPONENTS

Power Sensor Unit (Fig. 35)

1. Loosen screw connecting the unit to the front frame.
2. Slide unit forward.
3. Remove control plug by alternately loosening the two retaining screws.
4. Replace in reverse order.

Trip Solenoid (Fig. 36)

1. Remove opening springs.
2. Raise cross bar to gain additional access room.
3. Remove two nuts holding device to bracket.

Remove wiring cleats and connections to terminal board on Power Supply to free the trip solenoid for removal.

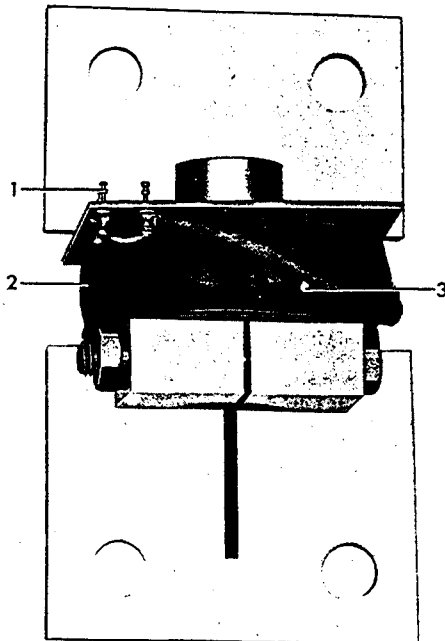

1. Terminal
2. External Ground Sensor Coil
3. White Polarity Dot

Figure 38 Ground Sensor Coil (Remotely Located)

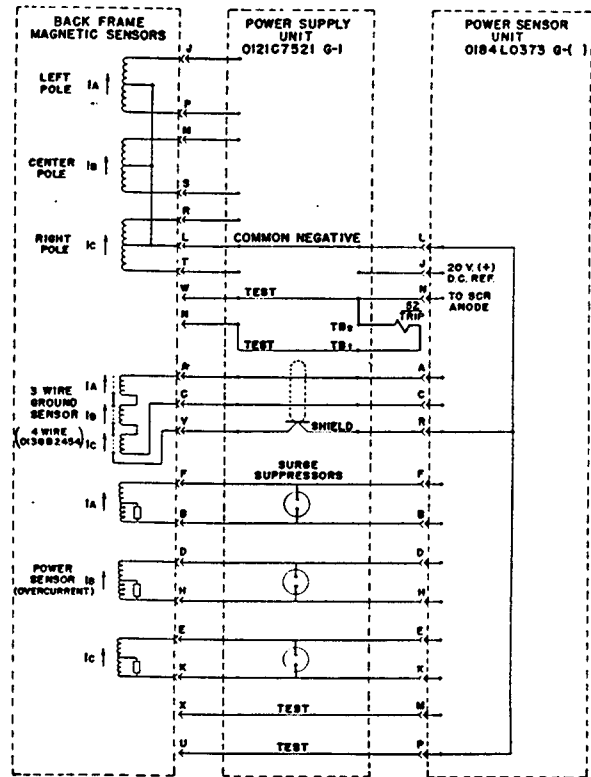
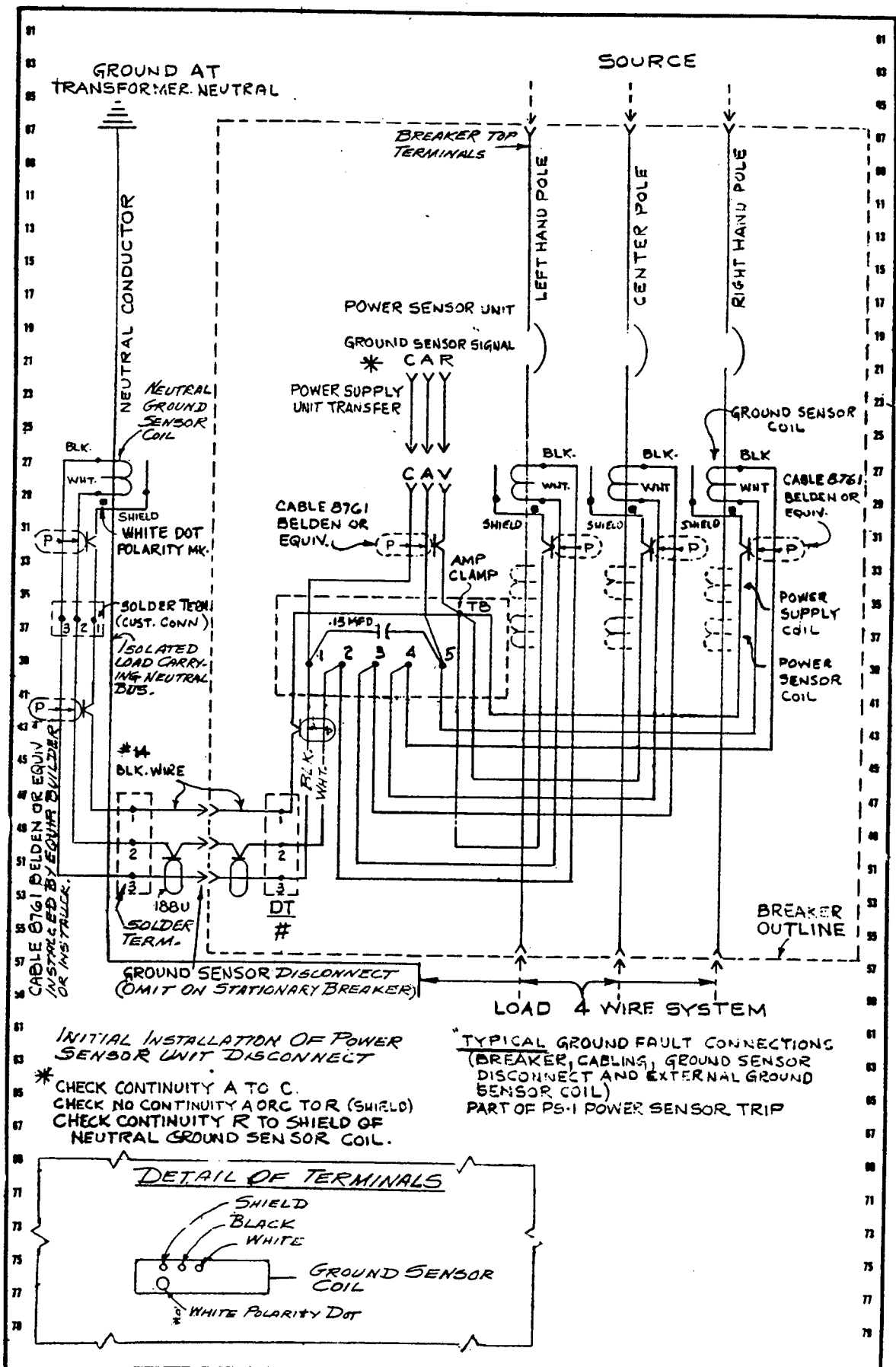

Figure 37 Power Sensor Cabling Diagram



Figure 39 Power Sensor Kit



INITIAL INSTALLATION OF POWER SENSOR UNIT DISCONNECT

- * CHECK CONTINUITY A TO C.
- CHECK NO CONTINUITY A OR C TO R (SHIELD)
- CHECK CONTINUITY R TO SHIELD OF NEUTRAL GROUND SENSOR COIL.

TYPICAL GROUND FAULT CONNECTIONS (BREAKER, CABLING, GROUND SENSOR DISCONNECT AND EXTERNAL GROUND SENSOR COIL) PART OF PS-1 POWER SENSOR TRIP

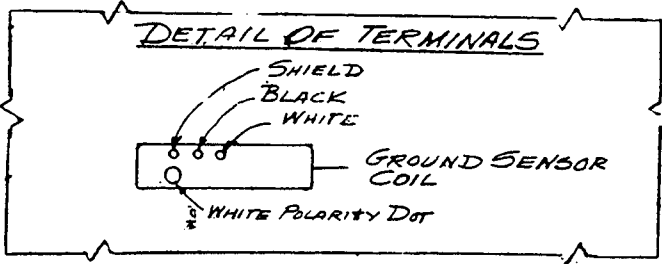

Figure 40 Ground Fault System

5. Replace in reverse order.

6. Check positive trip to obtain approx. $1/32''$ overtravel after armature is moved sufficiently to trip the breaker.

Power Supply (Fig. 34)

1. Remove trip solenoid wires from the terminal board on Power Supply.
2. Remove three bolts holding mounting bracket to mechanism frame.
3. Remove wiring cleats.
4. Remove disconnect plug by alternately loosening two retaining screws.
5. Remove Power Supply Unit with control wiring.
6. Reassemble in reverse order.

Sensor Coils (AK-3-50) Only (Fig. 32)

1. Disconnect plug between the Power Supply Unit and the sensor coils and remove tapped screw holding female plug to breaker mechanism frame.
2. Separate front frame from back frame as described under SEPARATION OF FRONT & REAR FRAMES.
3. On drawout breakers wired for the fourth ground sensor coil, unsolder external sensor coil

leads at terminal board on female disconnect plug. On stationary breakers unsolder twisted shielded pair from Terminal Board (Fig. 40).

4. Remove the four bolts connecting each coil assembly to the pole unit.
5. Remove the coil assemblies taking care not to damage the inter-connecting coil wires.
6. No further breakdown of the coil assemblies should be made. Do not remove the coils from around their iron core.
7. Replace coil assemblies in reverse order.

Sensor Coils (AK-3-75/100) Only (Fig. 33)

1. Disconnect control plug between Power Supply Unit and Sensor Coils.
2. If present, disconnect fourth ground sensor coil lead as described in Step 3 above.
3. Disconnect resistor board from back frame by removing two nuts from studs welded to back frame. Remove the two remaining hex head bolts and nuts. Lift board from the two studs.
4. Remove collar at end of primary disconnects by loosening two allen head bolts and sliding off collar.
5. Work coils toward end of stud. Starting with one outside pole, slip coils off stud and onto

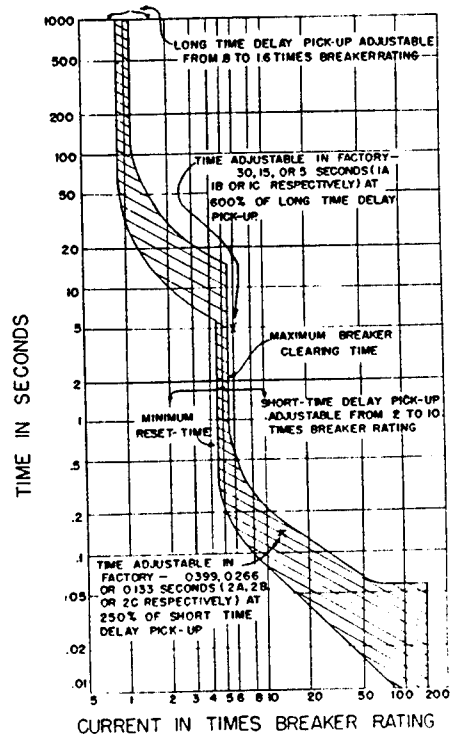
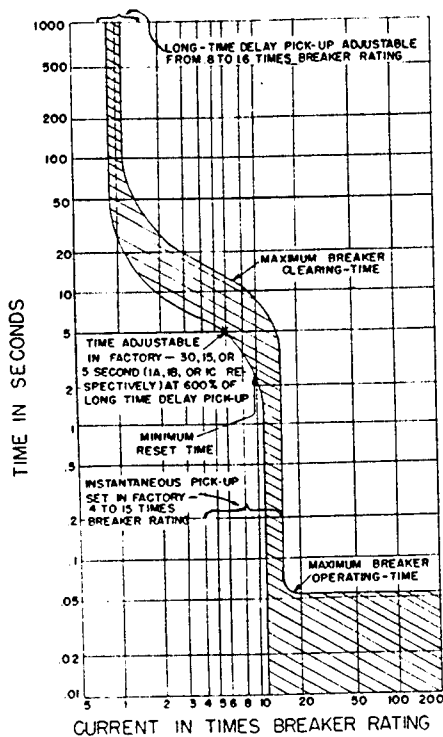

Figure 41 Typical Time-Current Characteristics for Magnet Overcurrent Trip Devices

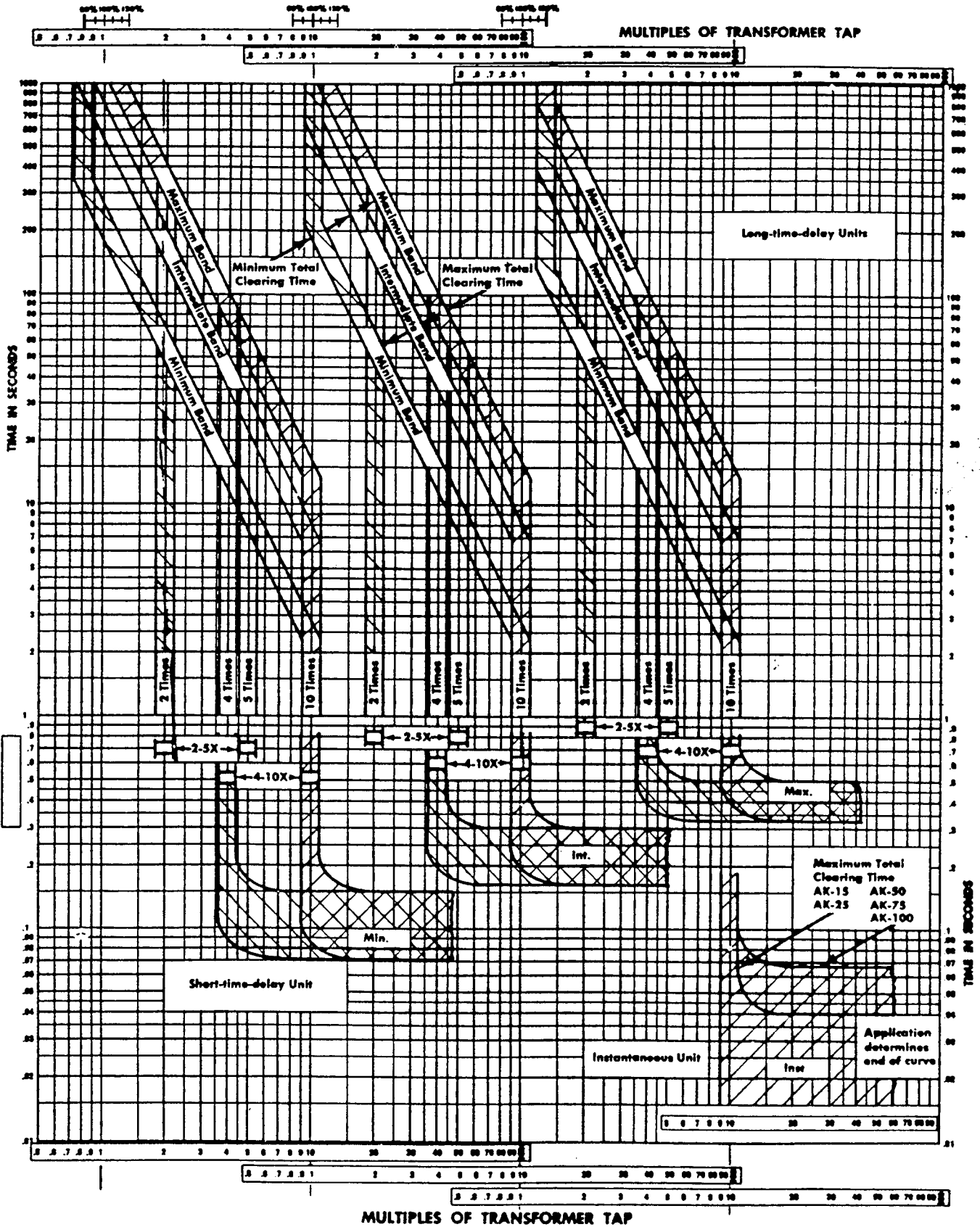

Figure 42A Long-Time-Delay, Short-Time-Delay and Instantaneous Time Current Curves For Solid-State Trip Device

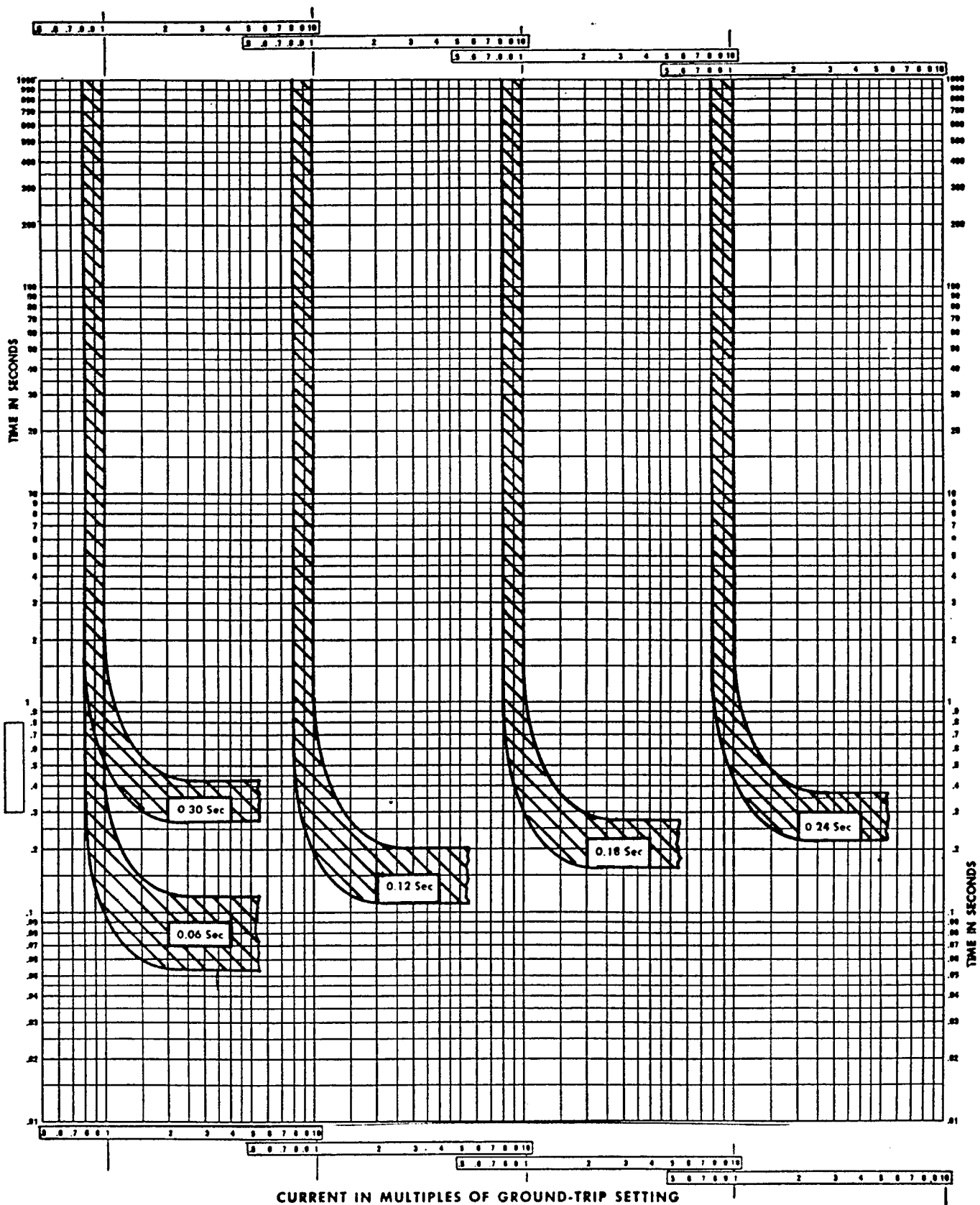

Figure 42B Ground Fault Short-Time-Delay Time-Current Curves For Solid-State Trip Device

your right arm or properly supported cylinder. Now move to center pole and outside pole until coils are removed. Place coils with resistor-board on clean flat surface. When removing coils from your arm be careful not to break or foul interconnecting coil wires. Also note location of spacers. Spacers may vary in thickness. Their purpose is to space coils out for a firm fit.

SELECTIVE TRIPPING

Selective tripping is obtained when the breakers in the electrical distribution system are arranged on the basis of a progressive series of time and current pickup. This will allow the breaker having the shorter time setting and the lower pickup to trip before the breaker having the longer time setting and the higher current pickup, provided the

fault is on the part of the line protected by the breaker having the lower setting. Hence, if a fault occurs in any part of the electrical system, only the breaker nearest the fault will trip.

In order to reduce the possibility of damaging the equipment and to provide maximum safety to the operator, the overload caused by a fault is removed in a minimum amount of time by selective tripping. Overloads producing current up to five or ten times the breaker rating are removed in a matter of a few cycles while currents in excess of this value are removed instantaneously.

For the exact characteristics and setting of each breaker in a selective system, reference should be made to the co-ordination chart furnished for the particular system.

BREAKER ACCESSORIES

PRIMARY DISCONNECTS AK-50 ONLY

The primary disconnects are attached to the circuit breaker studs at the rear of the breaker base. Each disconnect assembly consists of four pairs of opposed contact fingers. The contact fingers are secured to the breaker stud by two bolts which pass through the assembly and the stud of the enclosure. The disconnect fingers exert a set amount of force against the stationary stud through the action of the compression springs. Retainers and spacers hold the contact fingers in correct alignment for engagement with the stud. The amount of force which the fingers exert against the stud is determined by the degree to which the springs are compressed by the bolt and nut which hold the assembly together.

REPLACEMENT

If for any reason the disconnects must be replaced or removed, the position of the nuts on the bolts should be carefully noted and the number of turns of the nuts should be counted, so that in reassembly the original amount of compression can be restored by replacing the nuts to their former position on the bolts.

The primary disconnects should always be kept lubricated with G.E. Co. D50H47 grease.

SECONDARY DISCONNECTS

The secondary disconnects for all breakers serve as connections between breaker control circuit elements and external control circuits. They are used only on drawout breakers and are mounted on a horizontal cross-channel at the top rear of the breaker.

A terminal board serves the same purpose on stationary mounted and general purpose enclosure mounted breakers. These secondary disconnects allow removal of the breaker without the necessity of having to detach external connections.

The movable part of the secondary disconnects consists of an insulating body which holds a conducting spring-loaded plunger to which a flexible lead is attached. As the breaker moves into its enclosure, the plunger is depressed by sliding onto the stationary disconnects of the enclosure.

REPLACEMENT

1. Unfasten disconnect body from breaker cross-channel.
2. Open tabs which hold wires on inner side.
3. Pull contact tip loose from hollow tube.
4. Remove contact tip by cutting wire at its base.
5. Push wire through hollow tube of new disconnect assembly.
6. Strip insulation off end of wire to about 1/4 in. from the end.
7. Place new contact tip on end of wire and crimp.
8. Pull wire through hollow tube until contact fits snugly against end of hollow tube.
9. Crimp tab on other side of assembly to hold wire in place.

10. Any hollow tubes which are not used should be pushed into the disconnect body and held in that position by placing fiber spacers over inner ends of tubes and spreading tabs.
11. When all wires have been connected, refasten the body of the movable disconnect assembly to the breaker cross-channel.

DRAWOUT MECHANISM (FIG. 43)

Drawout breakers are furnished with a drawout mechanism which facilitates the inserting and withdrawing of the breaker from its enclosure. It provides a suitable means of forcing the breaker through the part of the inserting and withdrawal operations when the stationary and movable halves of the disconnects engage and disengage. For complete details of inserting and withdrawing the breaker, such as the number of racking handle strokes required to install or withdraw the breaker, refer to instruction GEK-7302 furnished with the breaker.

The drawout mechanism is equipped with a drawout trip interlock which prevents a racking operation from being performed when the breaker is closed. Inserting the breaker into the housing causes the racking pins on the housing to engage the semi-circular slot in the racking cam (4). In this position the breaker is ready to be fully racked-in by operating the racking handle (1). The first upward stroke of the racking handle causes the racking pin on the housing to engage the trip interlock link and pin assembly (2, 3), rotating the link (2) and causing the pin (3) to move upward against the adjusting screw on the interlock trip paddle. This trips the breaker and holds it trip-free during the entire racking operation. The fifth and final stroke of the

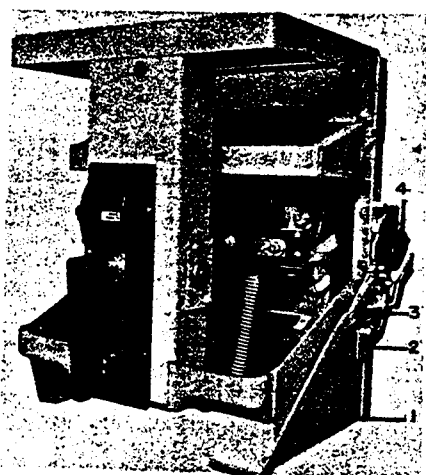

1. Racking Handle
2. Link
3. Pin
4. Racking Cam

Figure 43 Typical Drawout Mechanism

racking handle releases the trip interlock and allows the breaker to be closed, since the breaker is now fully racked-in.

ADJUSTMENTS (Fig. 43)

One adjustment on the trip interlock is required. With the breaker mechanism in the reset position and the racking cam (4) not engaging the racking pins on the housing, there should be at least 1/8 in. clearance between the top edge of the trip interlock pin (3) and the adjusting screw on the interlock trip.

The Drawout Mechanism for AK-2A/3A -50, 75, 100 Breakers is located in the equipment. Four racking pins (1, Fig. 44), two on either side of the breaker are furnished to facilitate the drawout mechanism tray in the equipment.

SHUNT-TRIPPING DEVICE (FIG. 45)

The shunt tripping device is mounted on a bracket attached to the left side of the operating mechanism (looking from the front).

A remote switch or relay contacts are used to close the circuit of the device causing the armature (9) to engage the trip paddle (11), thereby tripping the breaker. The spring (2) is used to return the armature to the neutral position after the breaker trips.

To prevent overheating, the coil (7) is cut off by contacts of the auxiliary switch which are open when the breaker is open.

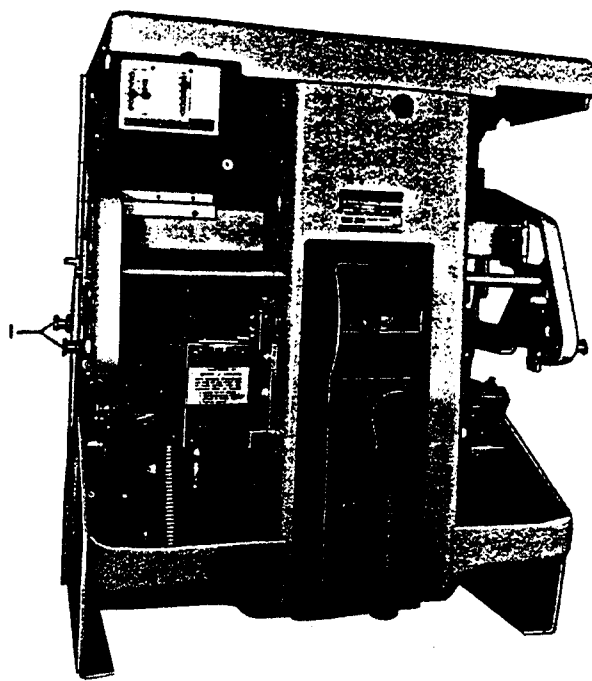

1. Racking Pins

Figure 44 AK-3A-50

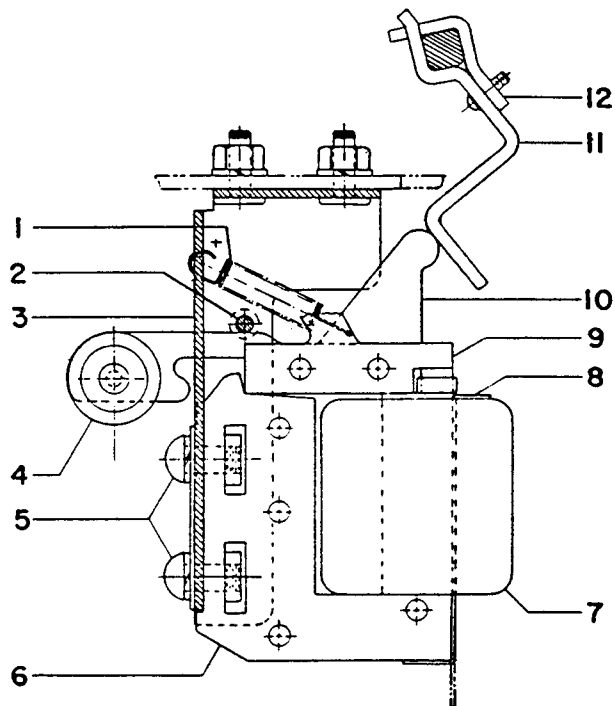

- | | |
|-----------|------------------|
| 1. Spring | 7. Coil |
| 2. Pin | 8. Clamp |
| 3. Frame | 9. Armature |
| 4. Weight | 10. Armature Arm |
| 5. Screws | 11. Trip Paddle |
| 6. Magnet | 12. Clamp |

Figure 45 Shunt Tripping Device

ADJUSTMENTS

From 1/32 in. to 1/16-in. over-travel of the armature is required when the breaker is tripped. If any adjustment is necessary to provide this amount of overtravel, the trip lever is bent in or out accordingly.

REPLACEMENT OF COIL (Fig. 45)

1. Disconnect leads to coil (7).
2. Remove magnet (6) and coil from frame (3).
3. Bend lower end of clamp (8) straight and remove.
4. Remove coil and install new coil in reverse order.

BELL ALARM AND LOCKOUT DEVICE (FIG.46)

The device operating link (2) is engaged with the breaker crossbar side-link pin (1), thereby operating the device whenever the breaker is tripped by the overcurrent trip devices, the under-voltage device or the drawout trip interlock. The shunt trip device and the manual trip button will defeat

the device. The bell alarm and lockout device can be reset only by the manual trip button on the escutcheon. If the lockout device is omitted, the device can be reset by manual trip button or by closing the breaker, provided the fault has been eliminated.

ADJUSTMENTS

1. Adjust the bell alarm-device latch (4) so that a clearance of 1/16 in. \pm 1/64 in. is maintained with the catch (15) when the breaker is closed.
2. With the breaker fully open, adjust the device adjusting screw (12), on the operating arm (13), for an overtravel of 1/16 to 3/32 of an in. after the device contacts are just touching. This will

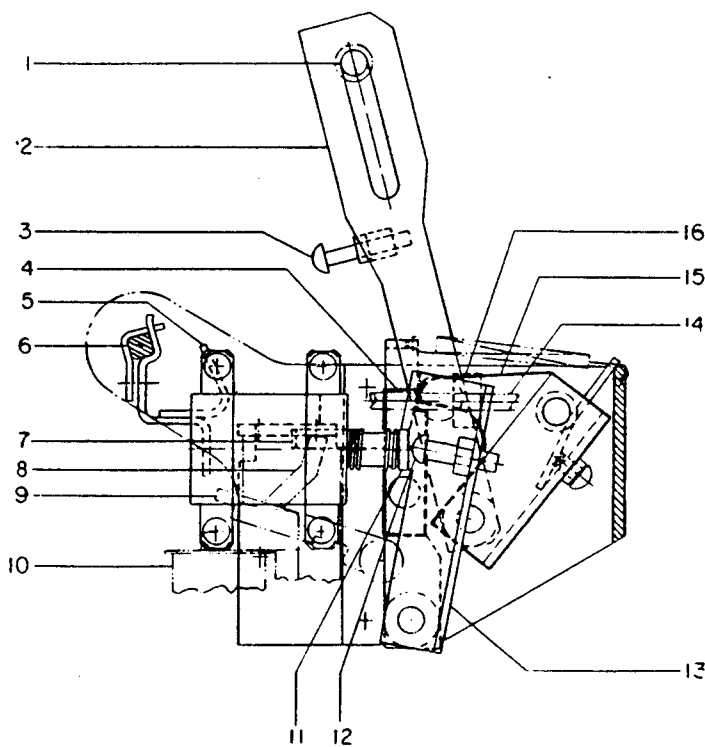

1. Crossbar Side-Link Pin
2. Operating Link
3. Lockout Adjusting Screw
4. Device Latch
5. Lockout Trip Paddle
6. Trip Shaft
7. Latch Release Strap
8. Shunt Trip Armature Lever
9. Shunt Trip Armature
10. Shunt Trip Device
11. Bell Alarm Plunger
12. Device Adjusting Screw
13. Operating Arm
14. Manual Trip Rod
15. Catch
16. Trip Rod Release Collar

Figure 46 Bell Alarm and Lockout Device
AK-50, AK-75 and AK-100

assure that the device is operated when the breaker is tripped by an overcurrent or under-voltage condition, and by the drawout trip inter-lock.

3. The lockout adjusting screw (3) should be adjusted so that it engages the lockout trip paddle (5) and displaces the trip shaft (6) when the breaker is opened. This assures that the breaker is locked open until the device is reset as described above. The lockout adjusting screw is furnished only with the lockout feature.
4. With the manual trip button fully depressed, position the trip-rod release collar (16) on the trip rod (14) so that the latch (4) and catch (15) are disengaged before the breaker opens.
5. This device is equipped with latch release strap (7) which is engaged by the shunt trip

armature lever (8) when the shunt trip device is operated. This defeats the device when the shunt trip device operates. The latch release strap (7), which is a part of the device latch (4), must be formed to hook around the shunt trip armature lever (8) in a manner that will assure the device latch and catch are disengaged before the breaker opens.

OPEN FUSE LOCKOUT DEVICE (FIG. 47)

The open fuse lockout device consists of 2 or 3 separately operated devices (one per phase) each wired in parallel to corresponding breaker fuses. This device is furnished on all AKU breakers, breaker fuse combinations and LB-1 protectors furnished after August, 1960. The devices are mounted on the left hand side of the breaker (looking from front). The purpose of this device is to trip the breaker upon the blowing of any one of the breakers fuses.

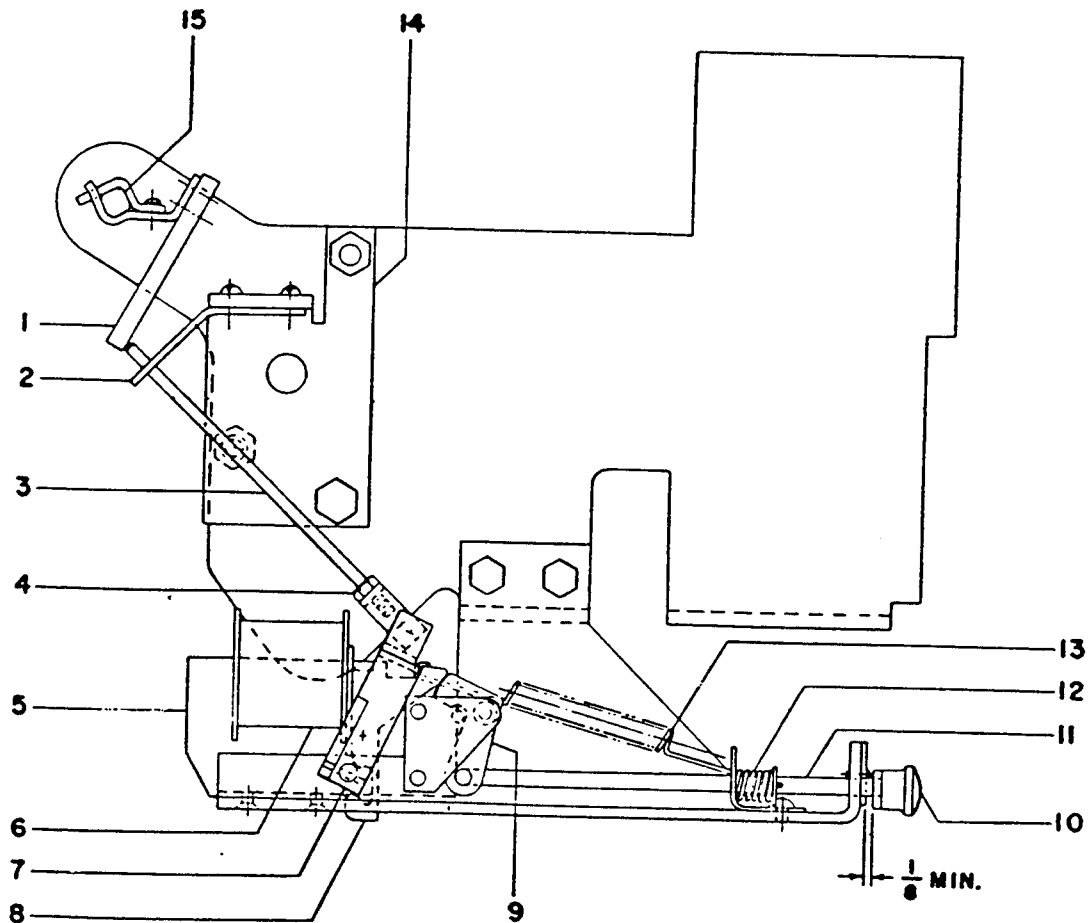

- | | | |
|----------------|------------------|---------------------------|
| 1. Trip Paddle | 6. Coil | 11. Rod, Reset Button |
| 2. Rod Guide | 7. Link Assembly | 12. Springs, Reset Rod |
| 3. Rod | 8. Armature | 13. Spring, Link Assembly |
| 4. Lock Nut | 9. Arm | 14. Mounting Bracket |
| 5. Trip Device | 10. Reset Button | 15. Trip Shaft |

Figure 47 Open Fuse Lockout Device

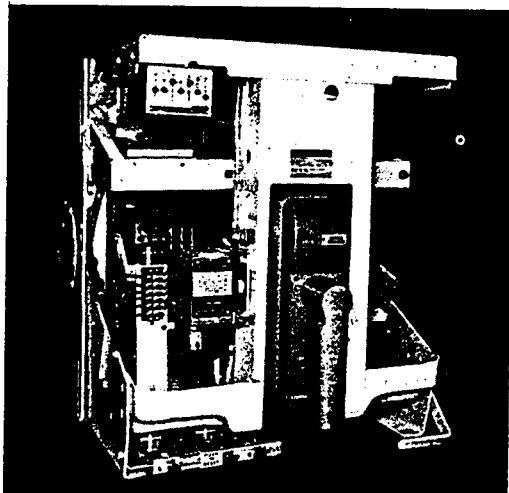

Figure 48 AKU-3-50 With Open Fuse Lockout Device

OPERATION

When any one of the breakers fuses blow, the coil (6), in that particular phase, is energized and the armature (8) closes. The armature (8) moving to the closed air gap position engages the trip paddle (1) and trips the breaker. With the armature closed, spring (13) discharges, pivoting the arm (9) in a clockwise direction and latches the armature (9) in the closed position. This motion also moves the reset button (10) forward in the extended position indicating which fuse has blown. The latch closed armature holds the breaker in the trip free position

until it is released by operation of the manual reset button (10). The coil (6) is de-energized as the breaker is tripped open.

ADJUSTMENTS

From 1/32 inch to 1/16 inch overtravel of the armature is required when the breaker is tripped. If adjustment is necessary, loosen lock-nut (4) and turn rod (3) in or out to obtain the proper overtravel. Retighten lock nut (4).

A 1/8" Min. dimension should be maintained for the reset button (10). To adjust reset button, loosen lock nut ahead of reset button and turn button until proper adjustment is made. Retighten lock nut.

REPLACEMENT

If it becomes necessary to replace coil (6) proceed as follows:

1. Remove five bolts connecting the device to the side plate and front frame. Lower lockout device, guiding rod (3) through rod guide (2). Continue lowering the device until movement is restricted by the device wiring harness.
2. Disconnect leads to coil (6).
3. Remove two screws holding the trip device to the device mounting plate.
4. Bend lower end of brass clamp straight.
5. Remove coil. Install new coil and replace parts in reverse order.

MISCELLANEOUS TOOLS

The following tools are recommended for proper maintenance of the breakers to which this maintenance manual applies.

Screwdrivers

- Phillips No. 1
- Phillips No. 2, 8 in. shank
- Phillips No. 3
- Long thin, slotted screw
- Standard, slotted screw
- Short shank, slotted screw
- Offset ratchet screwdriver, slotter (No. 3400)
Yankee
- Offset ratchet screwdriver, Phillips (No. 3412)
Yankee

Pliers

- Gas pliers, 8 in.
- Long nose, side cutting, 6 in.

- Waldes Truarc No. 2, straight
- Waldes Truarc No. 2, 90 degree angle

Socket Wrench (1/2 in. drive)

- | | |
|-------------------|------------------|
| Ratchet handle | 5/8 in. socket |
| Extension, 10 in. | 3/4 in. socket |
| Extension, 6 in. | 13/16 in. socket |
| 7/16 in. socket | 15/16 in. socket |
| 9/16 in. socket | |

End Wrenches

- 8 in. adjustable
- 1/4 in. -5/16 in. open end
- 1/2 in. -9/16 in. open end
- 5/8 in. -3/4 in. open end
- 3/8 in. -7/16 in. open end
- 11/32 in. -5/16 in. open end
- 5/8 in., 6 point open, box