

**14**

**GENERAL  
ELECTRIC**

## GENERAL ELECTRIC

1. GEH-1798A INSTRUCTIONS FOR TYPE  
AK-1-50 ELECTRICALLY OPERATED
2. GEH-1799 INSTRUCTIONS FOR TYPE  
AK-1-50 MANUALLY OPERATED
3. GEF-3878 RENEWALL PARTS FOR TYPES  
AK-1-50-1 AND AK-1-50-2

**INSTRUCTIONS**

---

*Switchgear*

# AIR CIRCUIT BREAKERS

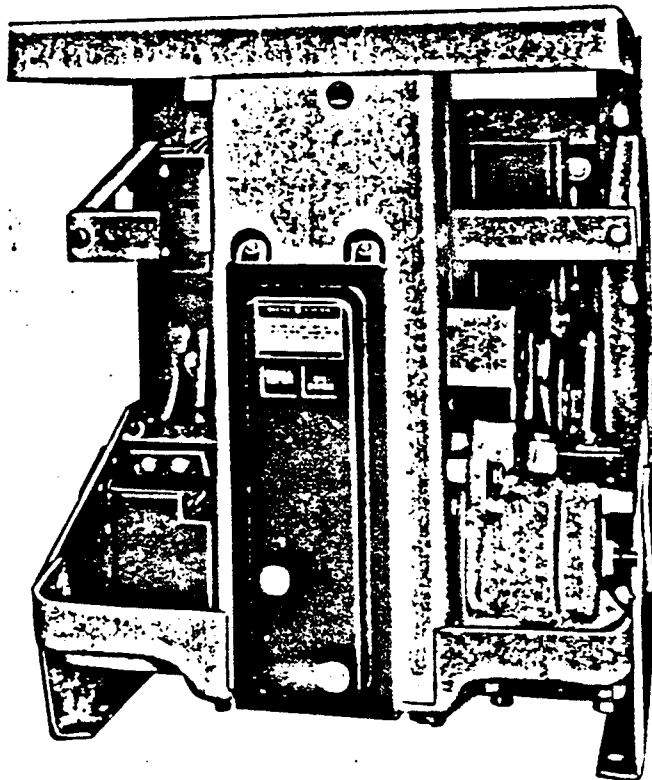

**Type AK-1-50  
Electrically  
Operated**

LOW VOLTAGE SWITCHGEAR DEPARTMENT  
**GENERAL**  **ELECTRIC**  
PHILADELPHIA, PA.

# CONTENTS

	PAGE
INTRODUCTION . . . . .	3
RECEIVING, HANDLING, AND STORAGE . . . . .	3
INSTALLATION . . . . .	3
LOCATION . . . . .	3
MOUNTING . . . . .	3
CONNECTIONS . . . . .	3
OPERATION . . . . .	5
MANUAL MAINTENANCE CLOSING . . . . .	5
ELECTRICAL . . . . .	5
MAINTENANCE . . . . .	5
INSPECTION . . . . .	6
REPAIR AND REPLACEMENT . . . . .	6
TROUBLE SHOOTING . . . . .	7
BASIC BREAKER COMPONENTS . . . . .	8
ARC QUENCHER . . . . .	8
POLE UNIT ASSEMBLY . . . . .	8
OPERATING MECHANISM . . . . .	11
AUXILIARY SWITCH . . . . .	12
ELECTRICAL CLOSING DEVICES AND CONTROLS . . . . .	15
PROTECTIVE DEVICES . . . . .	15
TIME DELAY UNDERVOLTAGE TRIPPING DEVICE . . . . .	15
INSTANTANEOUS UNDERVOLTAGE TRIPPING DEVICE . . . . .	16
SERIES OVERCURRENT TRIPPING DEVICE . . . . .	18
REVERSE CURRENT TRIPPING DEVICE . . . . .	19
MISCELLANEOUS . . . . .	21
SHUNT TRIPPING DEVICE . . . . .	21
BELL ALARM AND LOCKOUT DEVICE . . . . .	22
DISCONNECTS . . . . .	23
RENEWAL PARTS . . . . .	23

# AIR CIRCUIT BREAKERS

## TYPE AK-1-50-1, AND AK-1-50-2

### ELECTRICALLY OPERATED

#### INTRODUCTION

Before unpacking, installing, or attempting to operate the Type AK-1-50 Air Circuit Breaker described herein, these instructions should be thoroughly and carefully read.

The ratings for the AK-1-50 is as follows:

Continuous Current Rating	Interrupting Rating	Voltage	
		A.C.	D.C.
RMS Amperes	RMS Amperes	600	250
15* to 1600	50,000		

\*The interrupting rating is limited on the lower rated coils.

These circuit breakers are generally used for protection and control of feeder and branch circuits, including equipment in buildings, industries, power stations and for marine applications within the ratings designated.

The AK-1-50 breaker for D.C. application differs from the breaker used for A.C. applications. The difference in the D.C. breaker is an extra arcing contact per pole with corresponding difference in the upper stud and interrupter.

These instructions apply to breakers used for both D.C. and A.C. applications.

#### RECEIVING, HANDLING AND STORAGE

Immediately upon receipt of the circuit breaker, an examination should be made for any damage or loss sustained in transit. If injury or rough handling is evident, a damage claim should be filed at once with the transportation company and the nearest General Electric Sales Office should be promptly notified.

The circuit breaker should be unpacked as soon as possible after being received as difficulty may be experienced in making claim for damage, not evident upon receipt. Care should be used in unpacking to avoid damaging any of the breaker parts. Be sure that no loose parts are

missing or left in the packing material. Blow out any dirt or particles of packing material that may have accumulated on the breaker parts.

If the circuit breaker is not installed at once, it should be stored in a clean dry place and preferably placed in a vertical position. It should be supported to prevent bending of studs or damage to the breaker parts. It is advisable not to cover the breaker with any packing or other material that absorbs moisture which may cause corrosion of breaker parts. A covering of paper will prevent dust from settling on the breaker parts.

#### INSTALLATION

##### LOCATION

The Air Circuit Breaker should be installed in a clean dry place where it is readily accessible for operation, inspection and proper maintenance. Special enclosures are available for the installation of circuit breakers which may be subjected to dust and moisture or other unfavorable locations.

a plate bolted to the panel.

##### MOUNTING

Dead front circuit breakers are designed for mounting in a switchboard or an enclosing case. The mounting of dead front breakers consists of placing the breakers within the enclosed structure and connecting the power buses or cables and making the necessary control connections. The standard mounting depth from the back surface of the breaker base to the back side of the front panel is 16". The front cover of dead front breakers consists either of a hinged door with cut-out or

The structural surface to which the breaker is bolted must be flat throughout and the supporting structure must be of sufficient strength to hold the breaker firmly in place. Minimum cutout dimensions must be maintained in order to have proper electrical clearance.

##### CONNECTIONS

The connections to the circuit breaker studs should be firmly clamped or bolted in place to prevent excessive heating. The connecting cables or bus bars should have a current-carrying capacity specified to limit their temperature rise to that specified for the breakers. If these connecting cables or bus bars are not of sufficient size, heat will be conducted from them to the breaker so that the breaker cannot carry normal current without

*These instructions do not purport to cover all details or variations in equipment nor to provide for every possible contingency to be met in connection with installation, operation or maintenance. Should further information be desired or should particular problems arise which are not covered sufficiently for the purchaser's purposes, the matter should be referred to the General Electric Company.*

# Air Circuit Breaker Type AK-1-50

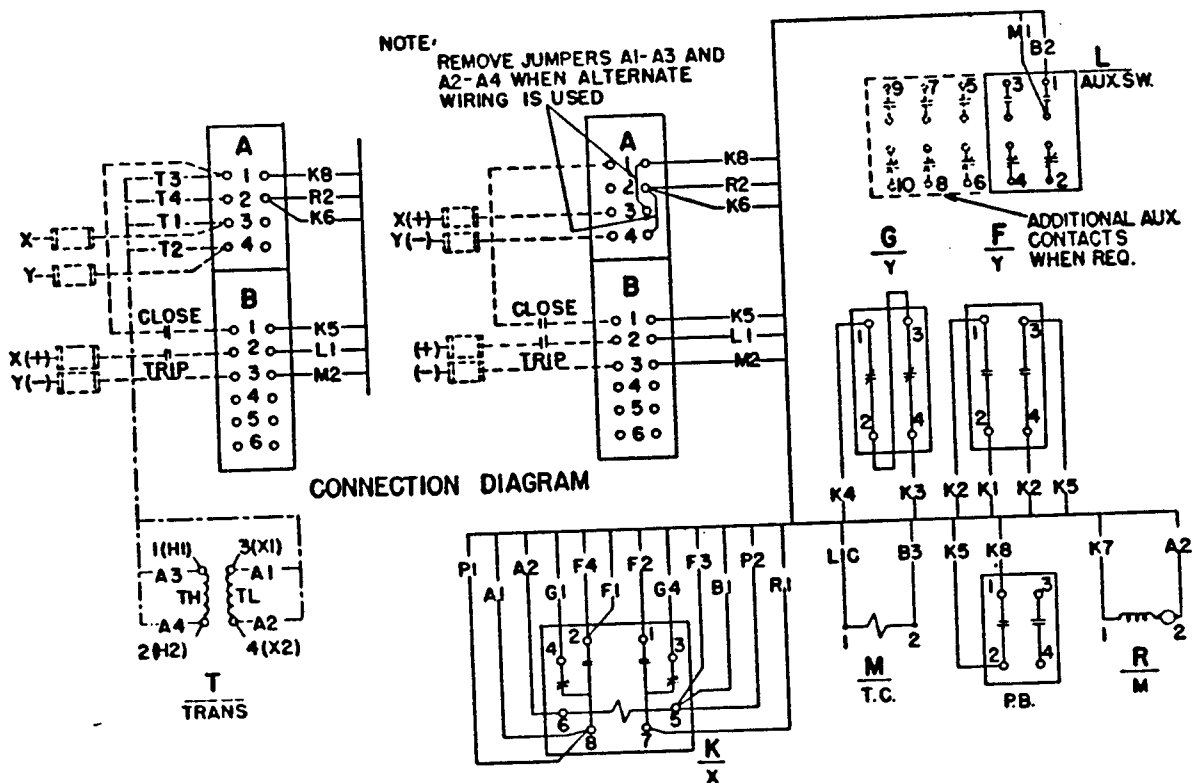

ALTERNATE WIRING USED WITH FOLLOWING POWER VOLTAGE RATING:

- 380/230 V. AC 50 S
- 460/230 V. AC 25 S
- 460/230 V. AC 50 S
- 460/230 V. AC 60 S
- 575/230 V. AC 25 S
- 575/230 V. AC 50 S
- 575/230 V. AC 60 S

CUSTOMER WIRING - - - - -

FACTORY WIRING - - - - -

FACTORY WIRING FOR ENCLOSED BRKRS. } - - - - -

CUSTOMER WIRING FOR STATIONARY BRKRS. } - - - - -

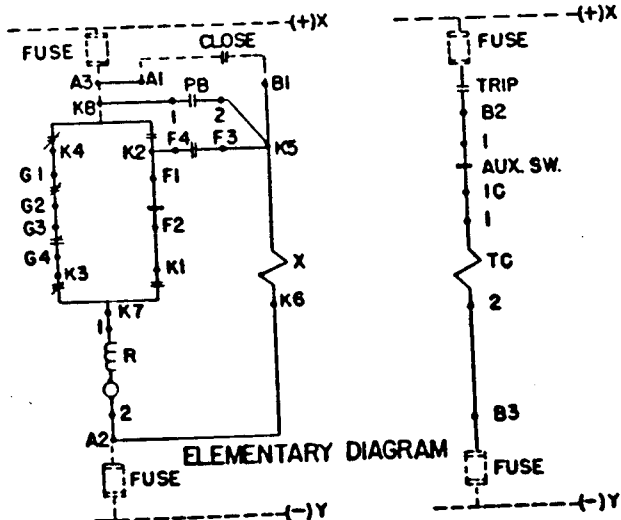

### LIST OF ABBREVIATIONS

- A- TERMINAL BOARD LOCATED LEFT SIDE FRONT VIEW
- B- TERMINAL BOARD LOCATED LEFT SIDE FRONT VIEW
- F- CUT OFF SWITCHES
- K- CLOSING RELAY TYPE H.G.A.(X)
- L- AUXILIARY SW. "O" "B" "D" CONTACTS TYPE SB-12 (AUX.SW)
- M- SHUNT TRIP (TC)
- P- PUSH BUTTON CLOSING SW. ON BRKR. (PB)
- R- CLOSING SPRING CHARGING MOTOR (M)
- T- AUXILIARY POWER TRANSFORMER (TRANS)

Fig. 1 Connection Diagram

exceeding the specified temperature rise. Connecting cables or bus bars should be supported so that the breaker studs will not be subjected to unnecessary strains.

### WIRING DIAGRAM

Fig. 1 shows the typical elementary and connection diagrams for the control system of electrically operated breakers. It shows the control circuit when the closing springs are discharged and the breaker is open. When rated voltage is applied to the control circuit, the motor will be energized through contacts K (8-4), G (1-2), G (3-4), K (3-7) to motor <sup>M</sup>52. The motor will charge the closing springs until the motor circuit is opened by cut-off switch contacts G (1-2) and G (3-4). When the G cut-off switches open the F cut-off switches close. Operation of the breaker

closing switch will energize the relay coil <sup>X</sup>52, which in turn opens contacts K (8-4) and K (3-7) and closes contacts K (8-2) and K (1-7). The circuit thru contacts K (8-2) and F (4-3) seals in the coil <sup>X</sup>52. The motor circuit is now energized

through contacts K (8-2), F (1-2), and K (1-7). The motor will then cause the charging crank (10) Fig. 7 to travel beyond the position of right angles to the paddle (11) Fig. 7. Beyond this position the springs will discharge independently of the charging motor and the breaker will close. When the breaker closes the control circuit reverts to its original position and the above cycle can be repeated.

Operating the breaker control switch to the trip position will cause the shunt tripping device to open the breaker. An auxiliary switch "a" contact will interrupt the flow of current through the shunt trip coil.

## OPERATION

### MANUAL MAINTENANCE CLOSING

To observe the operation of the breaker without power, with breaker open and springs discharged, proceed as follows:

1. Charge the closing spring with the maintenance handle (1), Fig. 3, until the indicator reads "charged".
2. Continue to operate the maintenance handle until the breaker closes.
3. Open the breaker by pushing the trip button (5), Fig. 2.

### ELECTRICAL

With the breaker in the open position and the closing springs discharged, as shown by their respective indicators, (3) and (8) Fig. 2, the cycle of operation is as follows:

1. The motor mechanism charges the closing

springs, in the front frame, through a linkage. This pre-charging operation occurs automatically if the control circuit is energized.

2. When the closing circuit is energized, either thru a closing switch on the breaker or a remote switch, the motor mechanism drives the spring charging lever over center. This discharges the closing springs and closes the breaker. After the breaker closes, the springs will automatically be pre-charged provided the control circuit has not been opened.

NOTE: The operating mechanism may reset when the closing springs are in the pre-charged position or during the over-running section of the closing operation.

3. After the breaker is tripped, the above cycle can be repeated.

## MAINTENANCE

**BEFORE INSPECTION OR ANY MAINTENANCE WORK IS DONE, BE SURE THAT THE BREAKER IS IN THE OPEN POSITION. ALL ELECTRICAL POWER, BOTH PRIMARY AND CONTROL SOURCES, SHOULD ALSO BE DISCONNECTED.**

**CAUTION:** Care must be taken when the circuit breaker is being installed and when any inspection or maintenance work is being done so that the breaker is in the open position and the closing springs are being restrained by the safety pin. The procedure for inserting the safety pin is given below.

The closing spring should be charged with the

maintenance handle (1), so that the safety pin (3) can be placed in the lower hold of the push rod (2), refer to Fig. 3. (The upper hole is used in the initial assembly of the springs). Continue to operate the maintenance handle, closing the breaker. This is done so that the safety pin takes the spring force.

Following the inspection period, the closing springs must be recharged, the safety pin removed from the push rod and the pin placed in the retaining spring clip adjacent to the push rod.

### INSPECTION

Periodic inspection of the circuit breaker

## Air Circuit Breaker Type AK-1-50

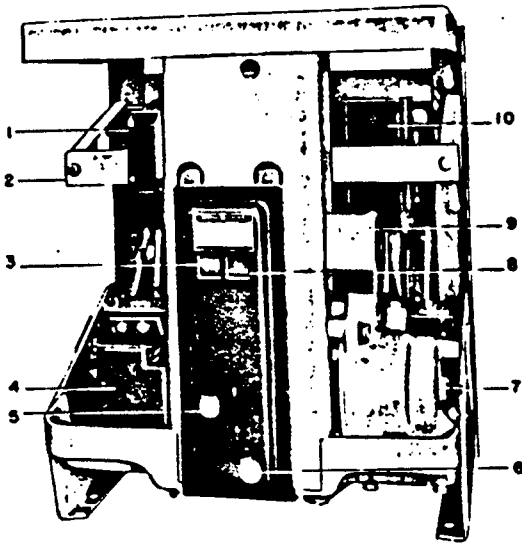

- |                       |                                                |
|-----------------------|------------------------------------------------|
| 1. Auxiliary Switch   | 7. Shaft For Manual Maintenance Closing Handle |
| 2. Channel Shaped Bar | 8. Spring Charged-Discharged Indicator         |
| 3. Position Indicator | 9. Motor Out-Off Switches                      |
| 4. Relay              | 10. Arc Quencher                               |
| 5. Manual Trip Button |                                                |
| 6. Closing Button     |                                                |

Fig. 2 Front View Of Breaker

is recommended at least once a year. More frequent inspections are recommended, if severe load conditions, dust, moisture or other unfavorable conditions exist. A complete inspection of the breaker, including contacts and arc quenchers, should always be made after the breaker has interrupted a short circuit current.

After the breaker has been installed, as well as at the regular inspection periods, slowly operate it manually several times as described above and observe whether the contacts line up properly and make sure that all parts move freely without binding or excessive friction.

If the breaker remains open or closed for a period of six months or more it is recommended that arrangements be made to open and close it several times in succession, preferably under load.

If overheating, not caused by overcurrent, is observed, a complete inspection of the breaker should be made including connections, contacts and flexible connectors.

At all times it is important not to permit pencil lines, paint, oil or other foreign materials to remain on the insulating surfaces of the breaker as they may cause low resistance between points of different potential and result in eventual electrical breakdown.

The breaker should be operated several times

at rated voltage to ascertain whether the control circuits are properly connected and that all electrical attachments are functioning properly.

The contacts should be inspected at the regular inspection periods and always after a known short circuit current has been interrupted, to ascertain whether the contacts are worn or pitted, in which case they should be dressed or replaced. It is necessary to remove the arc quenchers in order to properly inspect the contacts.

### LUBRICATION

In general, the circuit breaker requires moderate lubrication. Bearing points and sliding surfaces should be lubricated at the regular inspection periods with a thin film of G.E. Lubricant D50H15. Hardened grease and dirt should be removed from latch and bearing surfaces by using kerosene. **ALL EXCESS LUBRICANT SHOULD BE REMOVED WITH A CLEAN CLOTH IN ORDER TO AVOID ANY ACCUMULATION OF DIRT OR DUST.**

The use of cotton waste to wipe bearing surfaces should be avoided, as the cotton ravelings might become entangled under the bearing surfaces and destroy the surface of the bearing.

### REPAIR AND REPLACEMENT

In order to repair or replace contacts, operating mechanism or the overcurrent devices, the

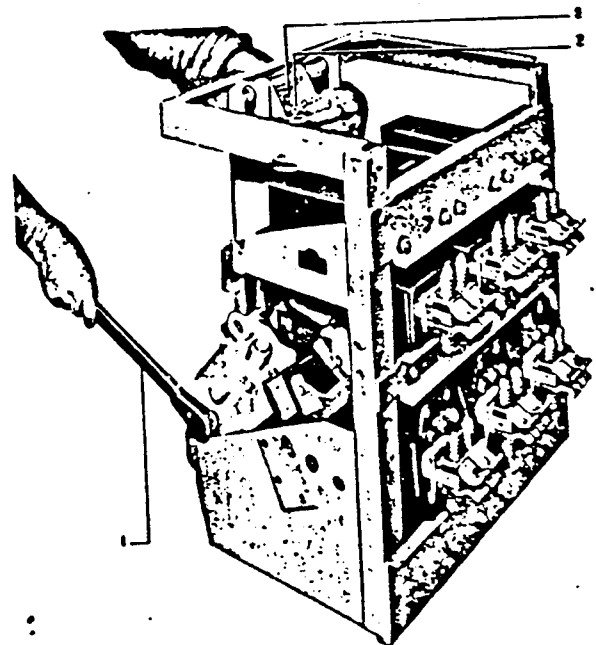

- |                              |             |               |
|------------------------------|-------------|---------------|
| 1. Manual Maintenance Handle | 2. Push Rod | 3. Safety Pin |
|------------------------------|-------------|---------------|

Fig. 3 View Showing Operation Of Breaker With Manual Maintenance Handle And Installation Of Safety Pin



front frame must be separated from the back frame. To separate the two frames proceed as follows:

1. The breaker contacts must be open with the safety pin in place. (See 'Maintenance').
2. Remove the two opening springs (on lower part of breaker) from the out-side pole units.
3. Remove the clevis pin (14) Fig. 5 from the center pole unit.

4. Remove the six nuts from the back frame using a socket wrench with an extension. These include the two nuts at the top of the frame.
5. Remove the operating rod (5) Fig. 10. The two frames can now be separated.

NOTE: It is recommended that the breaker be fastened to a suitable mounting base and a sling or hook hold the front frame as the bolts are being removed.

**TROUBLE SHOOTING**

TROUBLE	CAUSE	REMEDY
Overheating	<p>Contacts not aligned.</p> <p>Contacts dirty, greasy or coated with dark film.</p> <p>Contacts badly burned or pitted.</p> <p>Current carrying surfaces dirty.</p> <p>Bolts and nuts at terminal connections not tight.</p> <p>Current in excess of breaker rating.</p> <p>Excessive ambient temperature.</p>	<p>Adjust contacts.</p> <p>Clean contacts.</p> <p>Replace contacts.</p> <p>Clean surfaces of current carrying parts.</p> <p>Tighten, but do not exceed elastic limit of bolts or fittings.</p> <p>Decrease load, rearrange circuit or install larger breaker.</p> <p>Provide adequate ventilation.</p>
Failure to Trip	<p>Travel of tripping device does not provide positive release of tripping latch.</p> <p>Worn or damaged trip unit parts.</p>	<p>Re-adjust or replace tripping device.</p> <p>Replace trip unit.</p>
False Tripping	<p>Binds in overload device.</p>	<p>Replace overload device.</p>
Failure to Close and Latch	<p>Binding in attachments preventing resetting of latch.</p> <p>Chipped or worn latch.</p> <p>Latch out of adjustment.</p> <p>Latch return spring too weak or broken.</p> <p>Hardened or gummy lubricant.</p> <p>Safety pin left in push rod.</p> <p>Motor burned out.</p> <p>Control devices burned out.</p>	<p>Re-align and adjust attachments.</p> <p>Replace latch.</p> <p>Adjust latch.</p> <p>Replace spring.</p> <p>Clean bearing and latch surfaces.</p> <p>Remove safety pin.</p> <p>Replace motor.</p> <p>Replace device.</p>

## BASIC BREAKER COMPONENTS

### ARC QUENCHER

The arc quenchers should be inspected at the regular inspection period and if the barriers are cracked or eroded, they should be replaced.

#### REPLACEMENT

1. Remove the channel shaped retaining bar by removing two screws.
2. Lift the quencher clear of the movable arcing contacts.
3. During replacement be careful not to overtighten the screws which secure the channel shaped retaining bar. Overtightening the screws will bow the bar and leave the center arc quencher loose.

#### INSPECTING INNER, SLIDE, AND POCKET BARRIERS, FIG. 4

1. Remove arc quenchers (see above).
2. Remove screws holding spacer block (9).
3. Remove spacer block, steel backplate (8) and compound support (7).
4. Slide muffler (6) from slot and remove. The inner barriers (5) can now be removed for inspection.
5. Remove nut and withdraw stud (1) from cap (2).
6. Remove cap (2). The side (3) and pocket (4) barriers can now be removed.
7. Re-assemble and replace the arc quenchers in the reverse order. Tighten all fastenings after replacement.

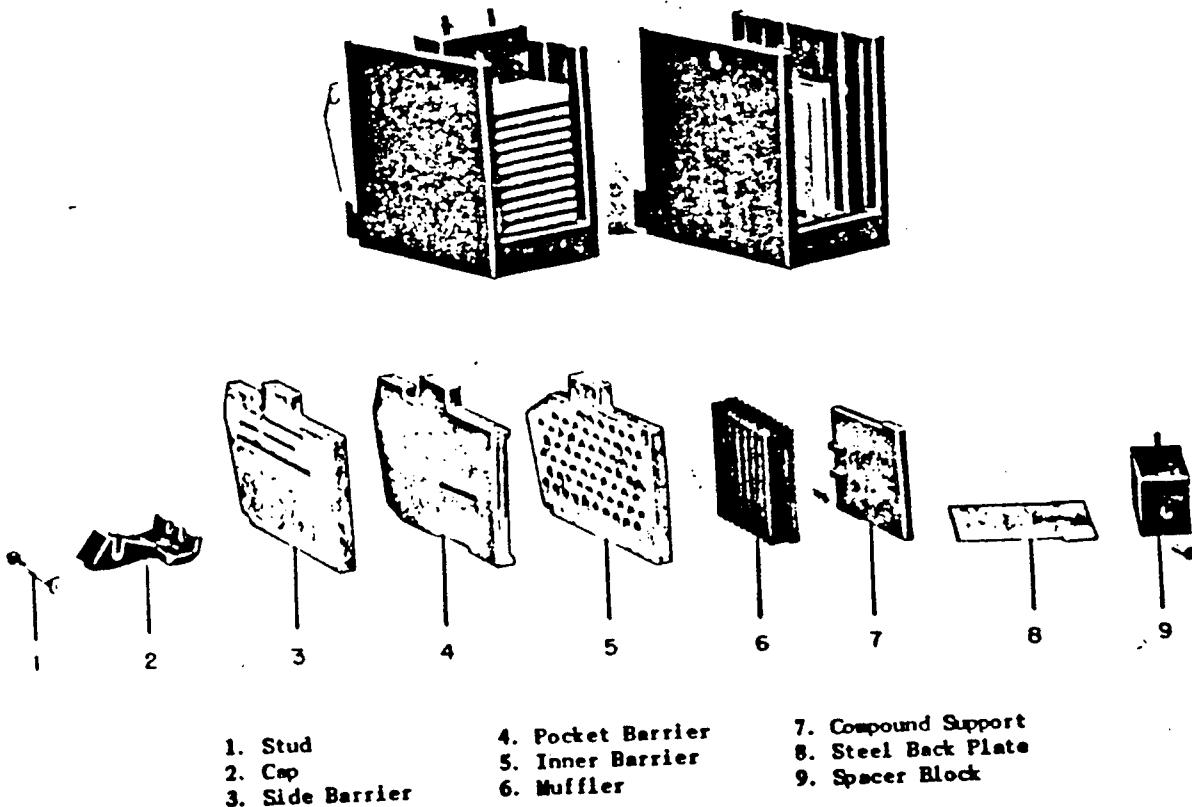

Fig. 4 Dis-Assembly Of Arc Quenchers To Inspect Inner, Side, And Pocket Barriers

### POLE UNIT ASSEMBLY

Each pole unit assembly consists of a set of arcing contacts, a set of main contacts, the operating linkage and the mounting base. See Fig. 5.

The stationary arcing contact consists of a set of parallel contact fingers (2), pin (3), and compression springs (22), which provide continuous contact pressure for the full travel of the contact.

Flexible braid leads shunt the pivot pin to prevent possible pitting at the pivot point when interrupting high currents.

The movable arcing contact assembly consists of parallel contact arms (4) carried on two movable pivot pins (8) and (19). The arcing contacts interleaf the main contacts and pivot with them about pin (19). This relative motion is obtained by linkages from the upper pin (7) to the breaker mechanism.

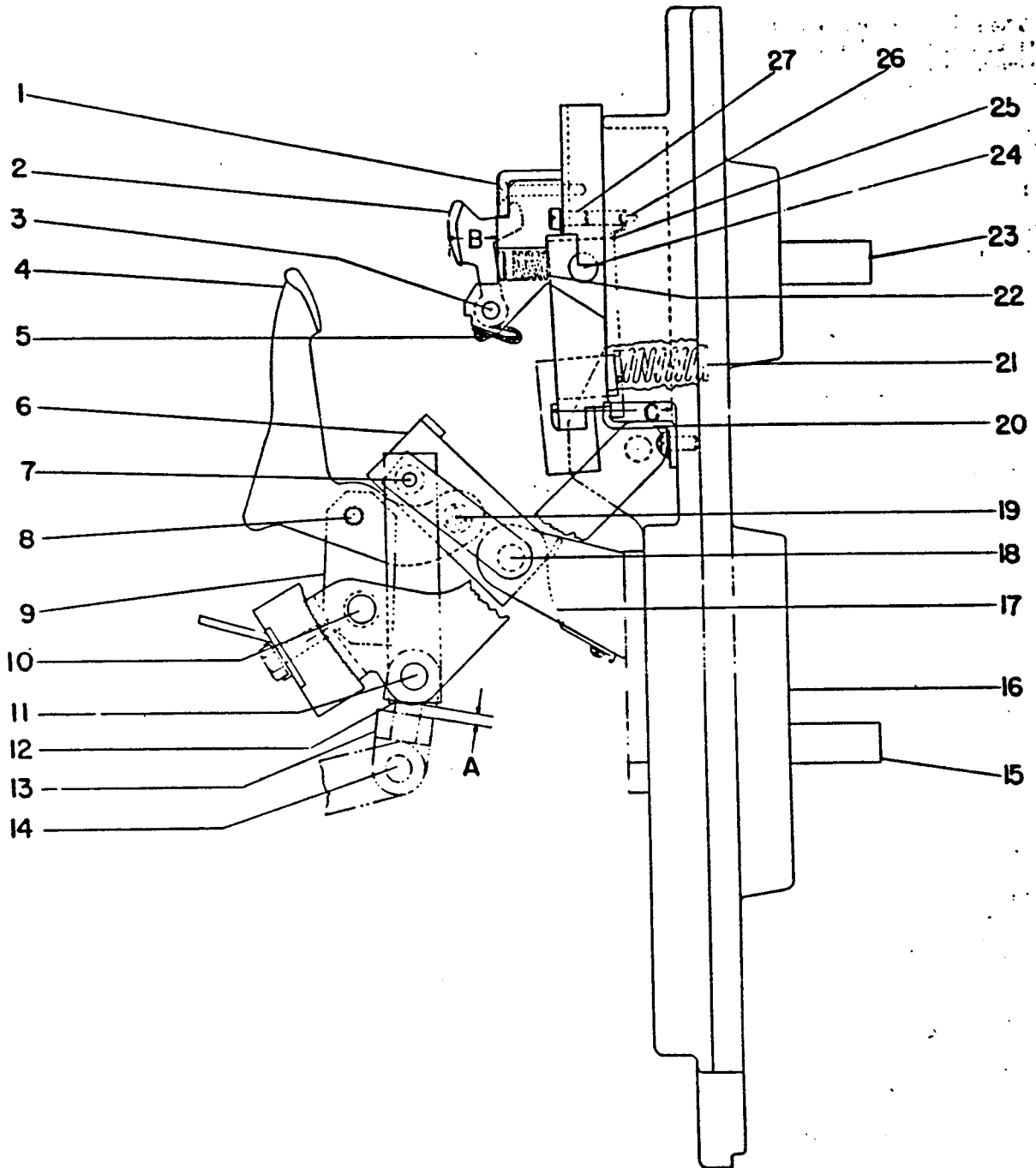

- |                            |                                 |                                |
|----------------------------|---------------------------------|--------------------------------|
| 1. Screw                   | 10. Pin (Insulating Link)       | 19. Pin (Movable Arcing Cont.) |
| 2. Sta. Arcing Contact     | 11. Pin (Side Link)             | 20. Side Link                  |
| 3. Pin (Sta. Arcing Cont.) | 12. Link                        | 21. Spring (Sta. Main Cont.)   |
| 4. Movable Arcing Contact  | 13. Clevis                      | 22. Spring (Sta. Arcing Cont.) |
| 5. Braid                   | 14. Clevis Pin                  | 23. Upper Stud                 |
| 6. Movable Main Cont.      | 15. Lower Stud                  | 24. Pin (Sta. Main Cont.)      |
| 7. Shouldered Pin          | 16. Pole Unit Base              | 25. Stationary Main Contact    |
| 8. Pin (Arcing Cont. Link) | 17. Spring (Main Movable Cont.) | 26. Screw                      |
| 9. Insulating Link         | 18. Pin (Movable Main Cont.)    | 27. Screw                      |

Fig. 5 Pole Unit Assembly

Fig. 5 (2150150)

AJN

## Air Circuit Breaker Type AK-1-50

The stationary main contact assembly includes main contacts and intermediate contacts. The intermediate contact surface extends beyond the main contacts and will, therefore, make before the main contacts and break after the main contacts. The number of contacts for each rating is given in Table I.

The movable main contacts pivot around a stationary pin (18), which holds them to the lower block, motion is obtained from a second pin (7), connected by an insulated link (12) to the breaker

mechanism. Steel springs (17) force the contacts against the pin to prevent pitting at the pivot point. The movable main contact assembly also contains main and intermediate contacts.

In order to function properly, a definite amount of contact pressure and contact wipe must exist between the movable and stationary contacts. Table I gives the figures for contact wipe and contact pressure. Both wipe and pressure should be checked during the regular inspection period.

TABLE I

Breaker Type	Main Contacts			Intermediate Contacts			Arcing Contacts		
	No. of Con-tacts	Pres-sure lbs.	Wipe in Inches	No. of Con-tacts	Pres-sure lbs.	Wipe in Inches	No. of Con-tacts	Pres-sure lbs.	Wipe in Inches
AK-1-50-1 For D. C.	3	55-65	1/16-3/32	1	55-65	*	3	25-35	5/16-7/16
AK-1-50-1 For A. C.	3	55-65	1/16-3/32	1	55-65	*	2	25-35	5/16-7/16

\* The Intermediate contact wipe should be at least 1/16" more than the main contact wipe.

### MEASURING CONTACT PRESSURE, FIG. 5

1. Remove arc quenchers, (see replacements under "Arc Quencher").
2. With the breaker open, measure the "B" dimension of the stationary arcing contact with the spring (22) full compressed.
3. Place a push-type scale against the stationary arcing contact and push the contact backward until the "B" dimension is 1/16" more than the measurement taken in item 2. The scale should then be read.

### MEASURING CONTACT WIPE, FIG. 5

1. Remove the arc quencher.
2. With the breaker open, measure the horizontal distance from the edge of the contact to the surface behind it. ("B" and "C" dimensions).
3. Close the breaker and repeat item 2. The difference between the readings in item "2 and 3" determines the wipe of the contacts. For safety reasons be extremely careful not to trip the breaker.

### ADJUSTING CONTACT WIPE AND PRESSURE, FIG. 5

1. With the breaker open, measure dimension "A".
2. Remove the clevis pin (14) and increase dimension "A" to increase the wipe, and decrease dimension "A" to decrease the wipe by turning the clevis (13).

NOTE: If the proper contact pressure does not exist when the contact wipe is within its limits, the stationary contact springs should be replaced.

### REPLACEMENTS, FIG. 5

#### Stationary Arcing Contacts (2)

1. Remove the upper plate by removing two screws (1).
2. Remove screw from braid (5).
3. Remove pin (3) allowing the stationary contacts and springs (22) to fall free.
4. Install new springs and stationary arcing contacts in reverse order.
5. Adjust contact wipe and pressure (see "Adjusting Contact Wipe and Pressure").

#### Movable Arcing Contacts (4)

The movable arcing contacts should be replaced when the stationary arcing contacts are replaced.

1. Separate the front frame from the pole unit frame (see "Repair and Replacement").
2. Remove pins (8) and (19) and withdraw the contacts.
3. Re-assemble parts in the reverse order.

#### Stationary Intermediate Contacts (9), Fig. 6

1. Remove screws (27) and remove bracket which holds pin (24) in place. See Fig. 5.
2. Remove clamp which holds lower part of stationary contact.
3. Remove pin (24) and screws (26).
4. Lift out the intermediate contacts.
5. Replace the contacts remembering to match the intermediate contacts on each pole.
6. Re-assemble in the reverse order.

## Movable Intermediate Contacts (8), Fig. 6

1. Remove the movable arcing contacts as described above.
2. Loosen spring (17). See Fig. 5.
3. Slide link (12) to the side and off of pin (7).
4. Slide pins (18) and (7) far enough to the side to allow the movable intermediate contact to be replaced.
5. Re-assemble parts in reverse order.

Always check the contact wipe and pressure following contact replacement.

## OPERATING MECHANISM

The electrically operated mechanism includes a motor and a gear reduction unit, which charges the closing springs (16) Fig. 7, through a crank shaft (14) Fig. 7. The crank shaft has an arm with a roller (12) Fig. 7, which rides on the closing cam (2) Fig. 8. The position of this closing cam roller is shown in Figs. 8A, 8B, and 8C. The closing cam is connected to the center pole unit thru a clevis, and through a cross bar controls the opening and closing of the contacts on all pole units.

With the breaker open and the closing springs discharged, the sequence of operation is as follows:

## CHARGING THE CLOSING SPRINGS, FIG. 7

1. The mechanism in position shown in Fig. 8A.
2. The motor turns the crank (10) Fig. 7, which is mounted on the output shaft of the gear reduction unit. The charging roller, which is on the face of the crank, has paddle arm (11) bearing on it.
3. As the crank turns, the roller pushes the paddle arm upward, thereby charging the closing springs through the spring charging arm (15) of the crank shaft.
4. As the charging roller approaches dead center a cut-off switch opens, de-energizing the motor circuit.
5. The breaker is now ready to close.

## CLOSING THE BREAKER

1. Mechanism in reset position, closing springs charged.
2. When the closing circuit is energized, the motor rotates causing crank (10) and roller (7) to move past dead center.
3. The crank (10) is free to rotate counter-clockwise. This permits release of the charging springs, rotating the crank shaft (14).
4. Referring to Fig. 8B and Fig. 8C, rotation of the crank shaft causes the closing roller (15) to push the closing cam (2) into the position shown in Fig. 8C.
5. With the closing cam in this position, the breaker contacts are closed through a clevis and linkage.

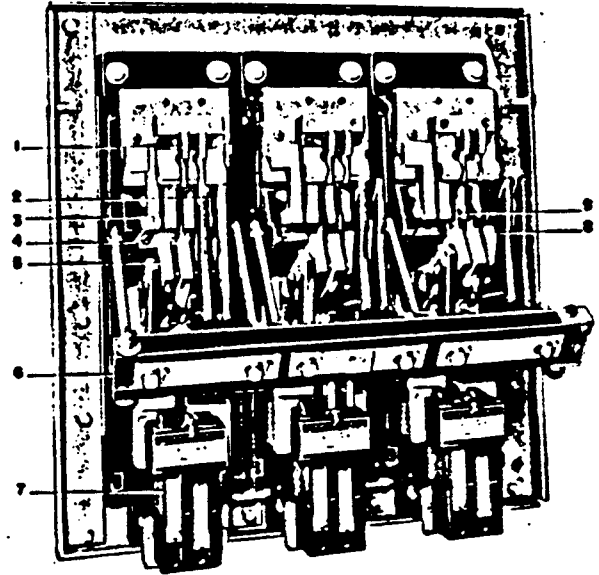

- |                              |                                    |
|------------------------------|------------------------------------|
| 1. Stationary Arcing Contact | 5. Movable Main Contact            |
| 2. Movable Arcing Contact    | 6. Cross Bar                       |
| 3. Stationary Main Contact   | 7. Series Overcurrent Device       |
| 4. Clamp                     | 8. Movable Intermediate Contact    |
|                              | 9. Stationary Intermediate Contact |

Fig. 6 Front View Of Back Frame Assembly

6. The prop (16) engages the closing cam (2), locking it in this position until the breaker is opened.
7. The motor will continue to operate until it has recharged the closing springs (16) Fig. 7, in preparation for the next opening and closing operation.

## OPENING THE BREAKER, FIG. 8

1. The rotation of the trip shaft (11) by any of the trip devices allows trip latch (10) to release the prop (5) and the forces from the contact and opening springs reposition the linkage of the operating mechanism into position shown in Fig. 8A.
2. The operating cycle can now be repeated.

## ADJUSTMENTS

All adjustments should be made with the operating mechanism in the reset position as shown in Fig. 8B. (The mechanism should be reset by manual operation).

1. The gap between the trip latch (10) and the roller of the reset latch (9) should be between 1/64 to 1/32 inches. This adjustment can be obtained by turning screw (6).
2. The center line of the trip latch (10) should pass through the center of the roller (9). Form the stop (14) to make this adjustment.

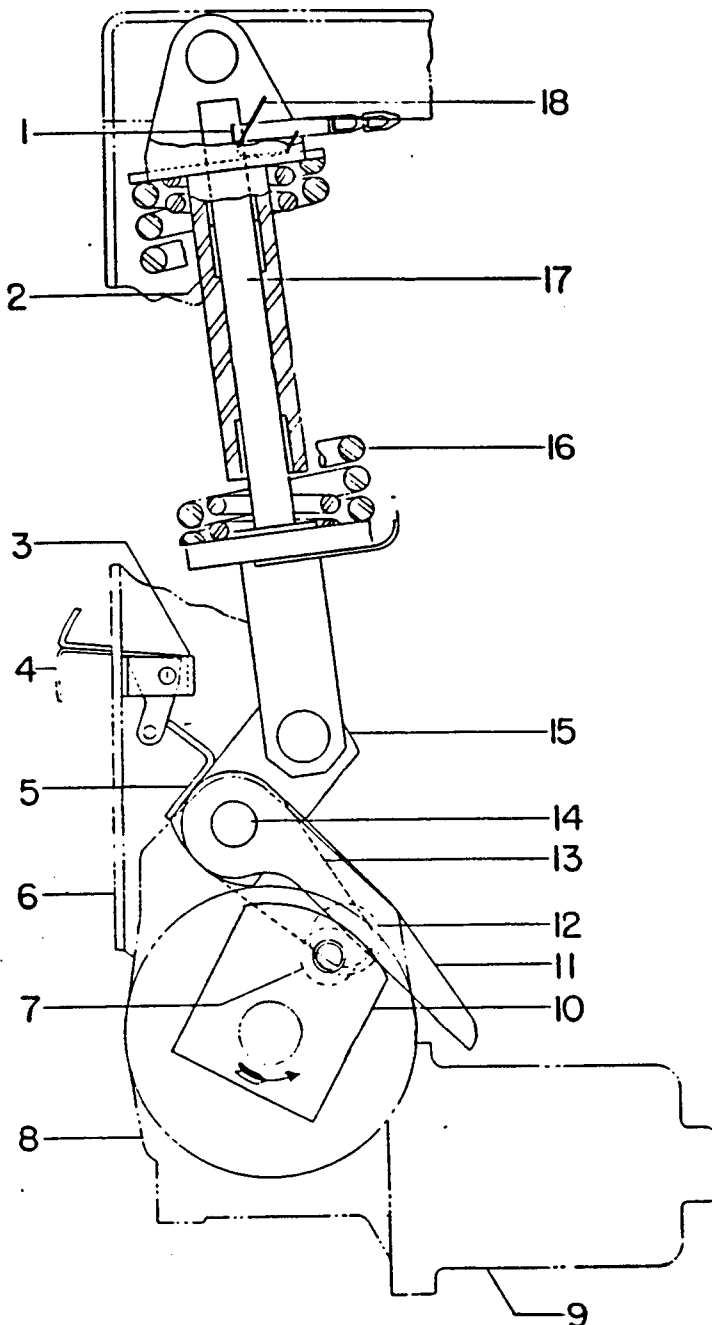

- |                        |                         |
|------------------------|-------------------------|
| 1. Pin                 | 10. Crank               |
| 2. Bushing             | 11. Paddle              |
| 3. Bracket             | 12. Closing Cam Roller  |
| 4. Indicator           | 13. Closing Cam Arm     |
| 5. Bracket             | 14. Crank Shaft         |
| 6. Frame               | 15. Spring Charging Arm |
| 7. Crank Roller        | 16. Closing Spring      |
| 8. Gear Reduction Unit | 17. Push Rod            |
| 9. Motor               | 18. Clip                |

Fig. 7 Closing Spring And Charging Mechanism

3. The distance between the roller on link (3) and prop (5) should be 1/64 to 1/32 of an inch. To obtain this gap advance or retard the nuts on the bottom of the rod thru reset spring (4).

**REPLACEMENT**

1. Remove the front frame (see "Repair and Replacement" under "Maintenance").
2. Remove pins holding spring charging arms (15) Fig. 7 to closing springs.
3. Remove two bolts underneath frame and two bolts from the front of the frame.
4. Remove any wiring which is attached to the mechanism frame.
5. Note the position of the trip paddles on the trip shaft. Remove the two cotter pins which hold the sections of the trip shaft together. The mechanism is now free to be removed.
6. Re-assemble parts in reverse order. Be sure to replace the trip shaft with the trip paddles in the right position.

**MOTOR AND GEAR REDUCTION UNIT**

The motor is mounted on the side of the gear reduction unit and through a worm gear and a planetary gear train drives the crank (10) Fig. 7 with a reduction of 1000:1.

**REPLACEMENT, FIG. 7**

1. Remove front frame (see "Repair and Replacement" under "Maintenance").
2. Remove pins from closing spring charging arm (15).
3. Remove the plate from right end of crank shaft (14).
4. Slide crank shaft to right until left end of shaft clears gear unit housing.
5. Remove the buffer stop which is mounted to the side of the frame and directly over the motor.
6. Open wire connections on motor, and remove wires attached to gear unit housing.
7. Remove four bolts on bottom of front frame and the bolt at the top of the gear reduction unit. The motor and gear reduction unit can now be removed.

The gear reduction unit contains 4 to 6 ounces of oil similar to Atlantic Refining Company's Grade HFS#3. It should not be necessary to add or change oil except when the gear reduction unit and motor are dis-assembled.

**AUXILIARY SWITCH**

The auxiliary switch is used to make and break various control circuits as the circuit breaker is opened and closed.

The auxiliary switch, refer to Fig. 10, is mounted on the left side of the front frame. As the cross bar (4) moves, with the contacts, to the open

Air Circuit Breaker Type AK-1-

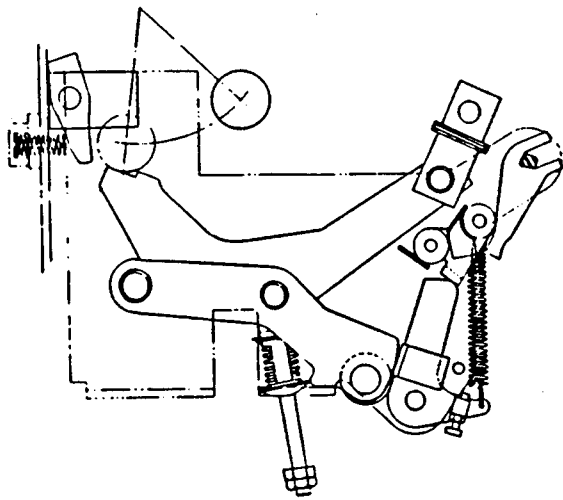

FIG-8A  
MECHANISM IN MOTION BEFORE  
RESETTING AS SHOWN IN FIG-8B

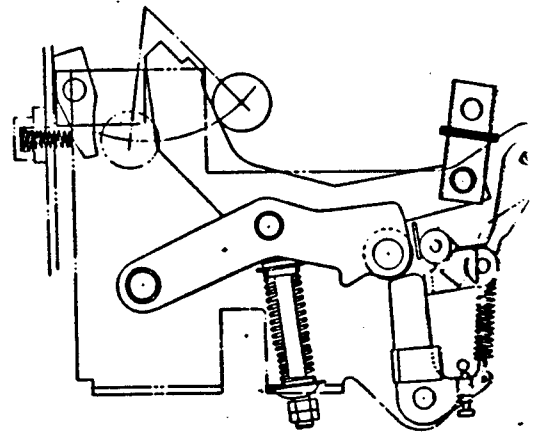

FIG-8B  
MECHANISM IN RESET POSITION  
(CLOSING SPRING CHARGED)

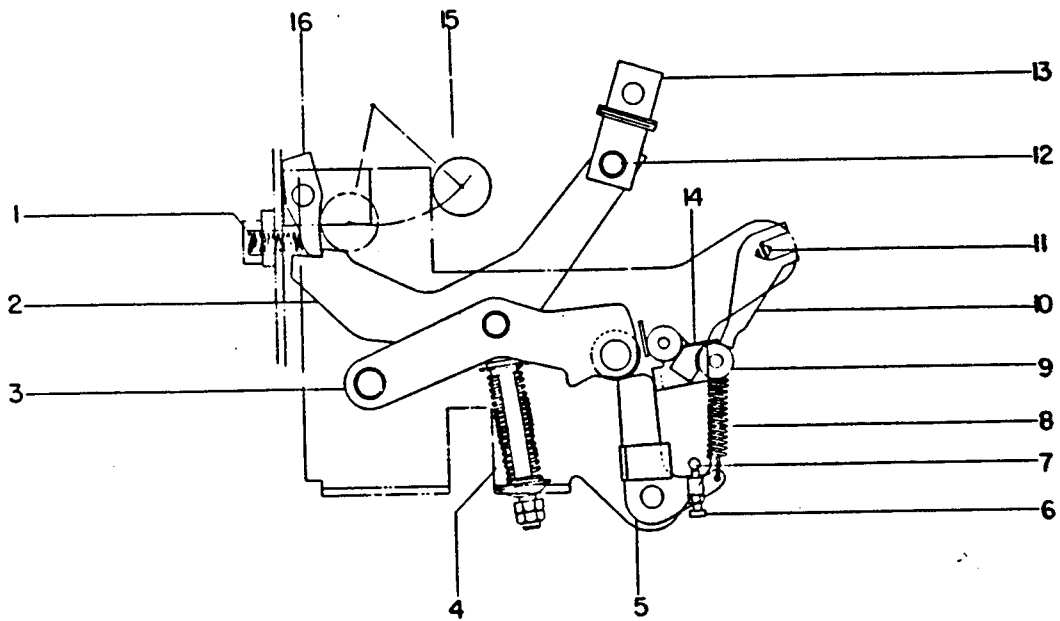

FIG-8C  
MECHANISM IN CLOSED POSITION  
(CLOSING SPRING DISCHARGED)

- |                        |                |
|------------------------|----------------|
| 1. Spring              | 9. Roller      |
| 2. Cam                 | 10. Latch      |
| 3. Link                | 11. Trip Shaft |
| 4. Reset Spring        | 12. Clevis Pin |
| 5. Prop                | 13. Clevis     |
| 6. Adj. Screw          | 14. Latch Stop |
| 7. Adj. Screw Stop Pin | 15. Roller     |
| 8. Prop Return Spring  | 16. Prop       |

Fig. 8 Operating Mechanism

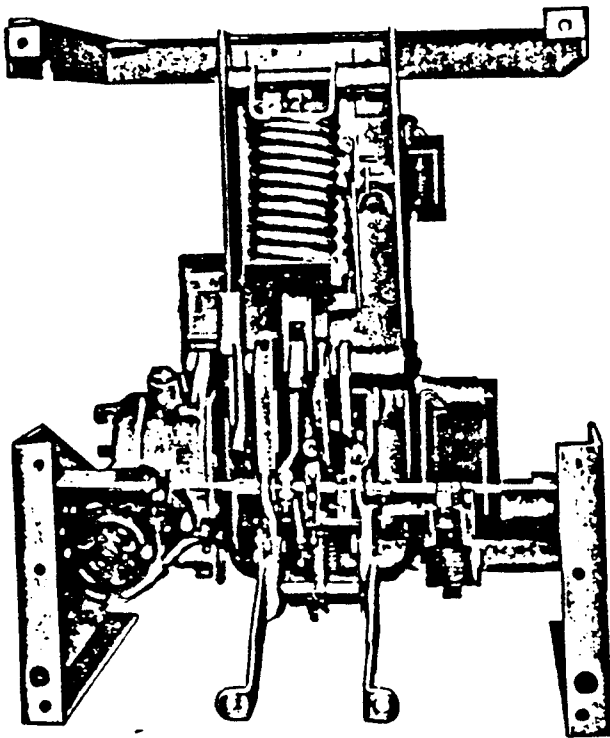
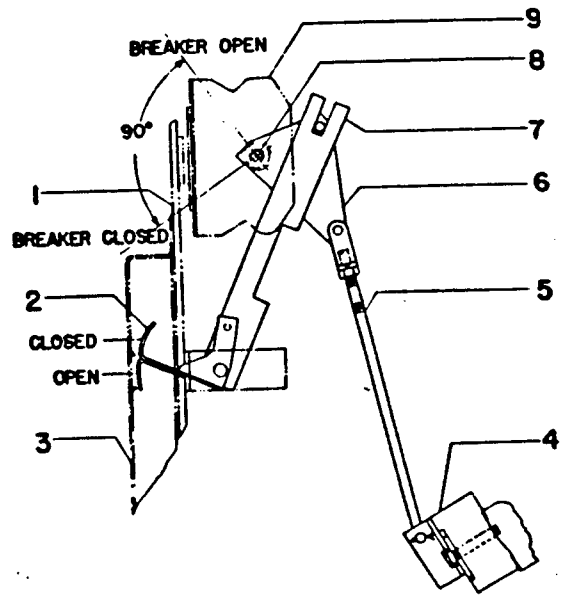
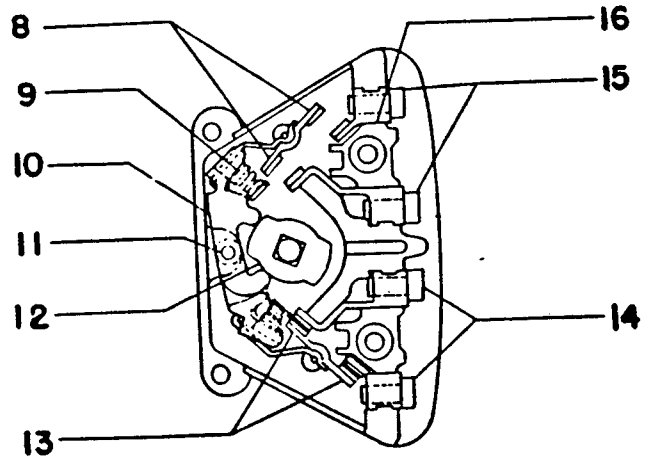
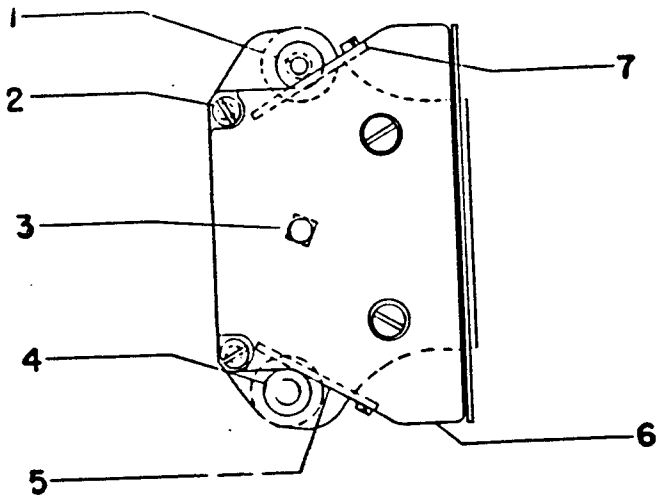

Fig. 9 Back View of Front Frame Assembly



- |                            |                    |
|----------------------------|--------------------|
| 1. Frame                   | 5. Operating Rod   |
| 2. Open & Closed Indicator | 6. Triangular Link |
| 3. Front Escutcheon        | 7. Link            |
| 4. Cross Bar               | 8. Operating Shaft |
|                            | 9. Auxiliary Shaft |

Fig. 10 Open And Closed Indicator Linkage



STAGE OF SWITCH SHOWING BREAKER IN OPEN POSITION

- |                  |                 |                   |                   |
|------------------|-----------------|-------------------|-------------------|
| 1. Mounting Bolt | 5. Bottom Cover | 9. Contact Spring | 13. 'b' Contacts  |
| 2. Tie Bolt      | 6. End Plate    | 10. Rocker Arm    | 14. 'b' Terminals |
| 3. Shaft         | 7. Top Cover    | 11. Pin           | 15. 'a' Terminals |
| 4. Screw         | 8. 'a' Contacts | 12. Cam           | 16. Barrier       |

Fig. 11 Rotary Auxiliary Switch



or closed position it operates a triangular link (6) through an operating rod (5). The triangular link rotates the operating shaft (8) of the auxiliary switch, which, through cams located on this shaft opens and closes the auxiliary switch contacts. The top terminals of the switch are 'a' contacts (open when the breaker is open) and the bottom terminals are 'b' contacts (closed when the breaker is open).

**REPLACEMENT, FIG. 10**

1. Disconnect all leads to auxiliary switch.
2. Remove two mounting bolts.
3. Disengage auxiliary switch shaft (8) from the triangular link (6).
4. Set arrow on new auxiliary switch shaft as shown in Fig. 10.
5. Push auxiliary switch shaft (8) into square hole in link (breaker open).
6. Replace mounting hardware and wiring.

**ELECTRICAL CLOSING DEVICES AND CONTROLS**

A closing switch and motor mechanism are provided for closing the breaker electrically.

**CLOSING SWITCH**

The closing button is mounted on the right side of the front escutcheon. When the closing button is pressed inward it engages a rod which in turn operates a switch, which is mounted on the front frame to the right of the operating mechanism.

To replace the closing switch, disconnect the wiring and remove the nuts which hold the switch to its mounting bracket.

**CUT-OFF SWITCHES**

The motor cut-off switches are mounted on the side of the front frame as shown in Fig. 12. At the end of the charging stroke, the cut-off switch (1) opens de-energizing the motor circuit. The cut-off switch (3) closes. When the closing control circuit is energized, the motor operates to discharge the closing springs and close the breaker. After this is completed, the cut-off switch (3) opens, de-energizing the motor circuit. The cut-off switch (1) closes, and the above cycle can be repeated.

**REPLACEMENT**

If the switches do not function properly, they

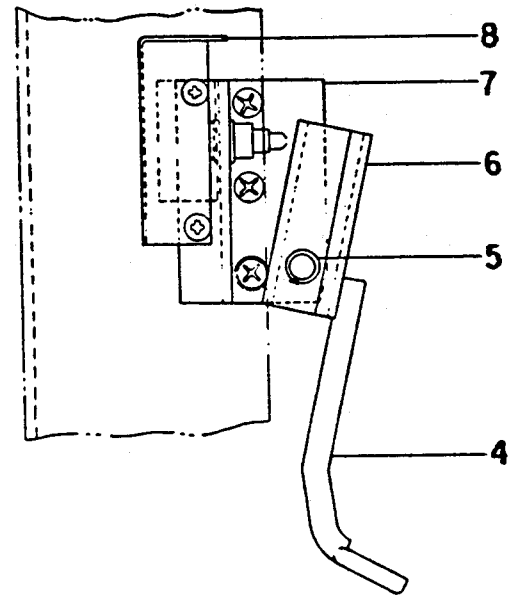
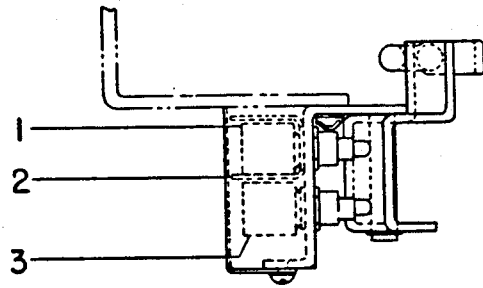

- |               |                   |
|---------------|-------------------|
| 1. "G" Switch | 5. Retaining Ring |
| 2. Insulation | 6. Lever Bracket  |
| 3. "F" Switch | 7. Mtg. Bracket   |
| 4. Rod        | 8. Cover          |

Fig. 12 Motor Cut-Off Switch

should be replaced by disconnecting the wiring and removing them from their mounting bracket.

**CONTROL RELAY**

The control relay is mounted on the left side of the front frame. It is used to open and close the motor circuit. To replace remove wiring and holding screws.

**PROTECTIVE DEVICES**

**TIME DELAY UNDERVOLTAGE TRIPPING DEVICE**

This device is mounted to a bracket on the left side of the operating mechanism (looking from the front). The purpose of this device is to trip the breaker for undervoltage. For rated voltage,

the armature (3) is attracted by the magnet (14). If the voltage falls below the predetermined value the magnet (14) releases the armature (3). Spring (4) then pulls armature (3) upward against the restraining force of the oil in cylinder (10); this action caused a time delay. When the spring overcomes the restraining force of the oil, the arma-

Fig. 12 (242C899)

ture engages screw (20) thus rotating the trip shaft and opening the breaker. (For parts reference refer to Fig. 13).

**ADJUSTMENTS, FIG. 13**

An adjusting screw (20) in the trip lever is used to allow from 1/32 to 1/16 inch overtravel after tripping the breaker.

Adjusting screw (2) is used to adjust the armature so that it will pick up at 80% of normal voltage and drop out between 30% and 60% of normal voltage.

Adjusting nut (8) on connecting rod (11) is intended for a minimum amount of adjustment of the time delay setting.

From 1/4 to 3/8 inch of oil should be maintained in the cylinder at all times. In order to make an inspection of the oil, the cylinder may be unscrewed from the cap. G.E. silicone oil 9981LT40NV or similar grade should be used in the cylinder.

**REPLACEMENTS**

Time Delay Undervoltage Device, Fig. 13

1. Disconnect coil leads.

2. Remove two screws from bracket (1). (Bracket is omitted when instantaneous undervoltage device is used).
3. Remove four mounting screws (21) and remove device.
4. Install new device in reverse order.

**Coil 15**

1. Disconnect leads to coil.
2. Remove two screws (16).
3. Remove magnet and coil assembly.
4. Straighten laminations around shading ring (5).
5. Remove shading ring and straighten lower end of coil clamp (13).
6. Remove coil. Install new coil in reverse order.

**INSTANTANEOUS UNDER-VOLTAGE TRIPPING DEVICE**

The undervoltage tripping device is constructed similarly to the time delay undervoltage tripping device with the exception that the cylinder (10), plunger (12), connecting rod (11), clevis (7), bracket (1), and adjusting nut (8), as shown in Fig. 13, are omitted.

The adjustments and replacements for this device are also the same as those for the time delay undervoltage tripping device.

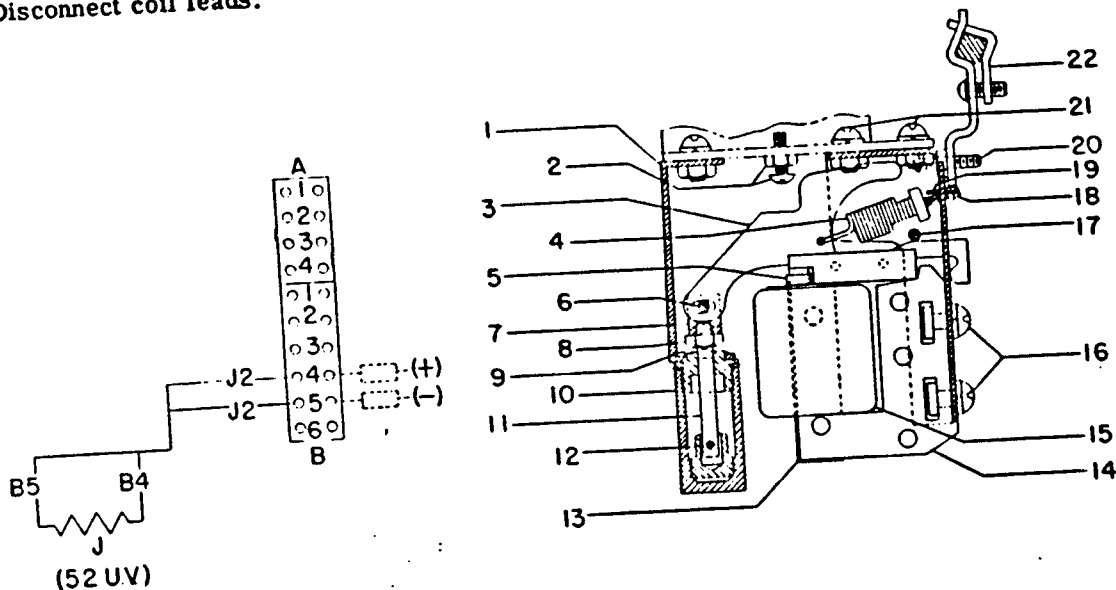

- |                          |                    |                         |
|--------------------------|--------------------|-------------------------|
| 1. Bracket               | 8. Adjusting Nut   | 16. Screws              |
| 2. Adjusting Screw & Nut | 9. Cap             | 17. Pin                 |
| 3. Armature              | 10. Cylinder       | 18. Adjusting Screw     |
| 4. Spring                | 11. Connection Rod | 19. Locking Wire        |
| 5. Shading Ring          | 12. Plunger        | 20. Adjusting Screws    |
| 6. Pin                   | 13. Clamp          | 21. Mounting Screws     |
| 7. Clevis                | 14. Magnet         | 22. Trip Paddle & Clamp |
|                          | 15. Coil           |                         |

Fig. 13 Time Delay Undervoltage Tripping Device

Fig. 14 (P-6123678)

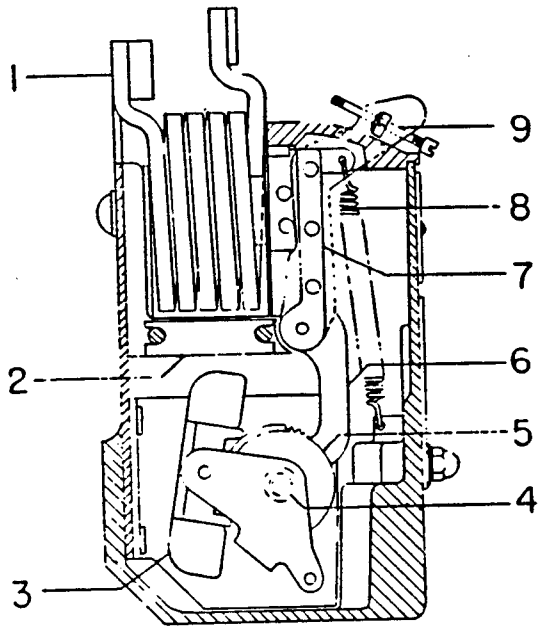

LEFT SIDE VIEW SHOWING  
SHORT TIME DELAY MECHANISM  
FIG. 9A

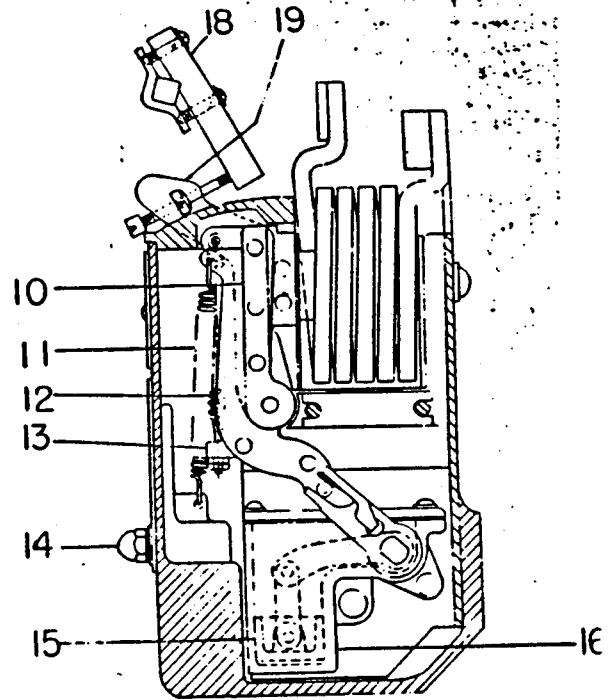

RIGHT SIDE VIEW SHOWING  
LONG TIME DELAY MECHANISM  
FIG. 9B

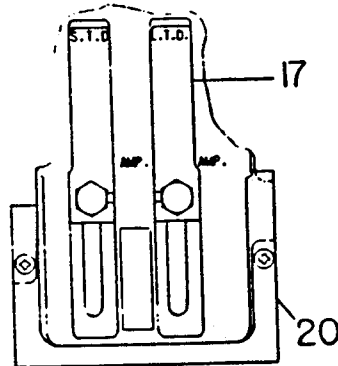

FRONT VIEW SHOWING  
MOUNTING BRACKET

- |                    |                               |                                    |
|--------------------|-------------------------------|------------------------------------|
| 1. Series Coil     | 8. S.T.D. Calibration Spring  | 15. Plunger                        |
| 2. Magnet          | 9. Trip Arm                   | 16. Cylinder                       |
| 3. Pallet          | 10. L.T.D. Armature           | 17. Calibration Plate              |
| 4. Pinion          | 11. L.T.D. Calibration Spring | 18. Trip Paddle                    |
| 5. Escape Wheel    | 12. Instantaneous Trip Spring | 19. Trip Paddle<br>Adjusting Screw |
| 6. Driving Segment | 13. Spring Holder             | 20. Clamping Bracket               |
| 7. S.T.D. Armature | 14. Calibration Clamp Nut     |                                    |

Fig. 14 Series Overcurrent Tripping Device

## SERIES OVERCURRENT TRIPPING DEVICE

Each series overcurrent tripping device is enclosed in a molded case and mounted by three screws and a bracket to the lower part of the pole unit base.

The device can be provided with the following tripping combinations:

1. Long time delay, short time delay and instantaneous tripping.
2. Long time and short time delay tripping only.
3. Long time delay and instantaneous tripping.
4. Short time delay and instantaneous tripping.
5. Short time delay tripping only.
6. Instantaneous tripping.
  - (a) Adjustable
  - (b) Non-adjustable

### SHORT TIME DELAY TRIPPING, FIG. 14

The armature (7) is retained by calibrating spring (8). After the magnetic force, produced by an overcurrent condition, overcomes this restraining force, the armature movement is further retarded by an escapement mechanism which produces an inverse time delay characteristic. The mechanism is shown on Fig. 14a.

### LONG TIME DELAY TRIPPING, FIG. 14

The armature (10) is retained by the calibration spring (11). After the magnetic force, produced by an overcurrent condition, overcomes this restraining force, the armature movement is further retarded by the flow of silicone oil in a dashpot, which produces an inverse time delay characteristic. The mechanism is shown on Fig. 14b.

### INSTANTANEOUS TRIPPING, FIG. 14

- (a) Adjustable instantaneous tripping takes place after the magnetic force produced by an overcurrent condition, overcomes the restraining force of the calibration spring which can be adjusted by the calibration clamp nut (14).
- (b) Non-adjustable instantaneous tripping takes place after the magnetic force produced by an overcurrent condition overcomes the restraining force of a non-adjustable spring.

Selective tripping is obtained when the breakers in the electrical distribution system are arranged on the basis of a progressive series of time and current pickup. This will allow the breaker having the shorter time setting and the lower pickup to trip before the breaker having the longer time setting and the higher current pickup, provided the fault is on the part of the line protected by the breaker having the lower setting. Hence, if a fault occurs in any part of the electrical system, only the breaker nearest the fault will trip.

In order to reduce the possibility of damaging the equipment and to provide maximum safety to the operator, the overload caused by a fault is removed in a minimum amount of time by selective tripping. Overloads producing current up to 5 or 10 times the breaker rating are removed in a matter of a few seconds while currents in excess of this value are removed in a fraction of a second.

For the exact characteristics and setting of each breaker in a selective system, reference should be made to the coordination chart furnished for the particular system.

### ADJUSTMENTS, FIG. 14

Calibration clamping nuts (14) are used to set the desired pickup for the adjustable elements.

To adjust for approximately  $1/32$ " overtravel of trip arm (9) after tripping:

1. Check trip latch engagement. See "Adjustments - Operating Mechanism".
2. Loosen the locknut and turn the adjusting screw (19) on the trip arm (9). The screw should not touch the trip paddle when the breaker is "open" and the latch is reset, but should have a clearance not exceeding  $1/32$ ".
3. Tighten the adjusting screw locknut on the trip arm.

### REPLACEMENT

1. Remove front frame (See "Repair and Replacement").
2. Remove the bolts holding the coil to the lower stud.
3. Remove bracket and mounting screws.

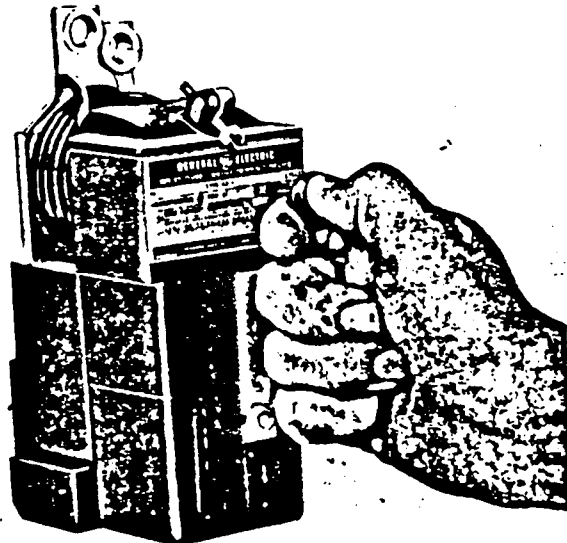

Fig. 15 Checking Travel Distance Of Series Overcurrent Tripping Device

4. Before installing a new device, check the travel of the trip arm with a rod or wire and push the armature solidly against the magnet (see Fig. 15). The trip arm should move at least  $5/32"$ . If there appears to be insufficient movement of the trip arm, or if the armature appears to be binding, the device should not be used.
5. Replace new device in reverse order.
6. Adjust device as described above.

NOTE: No component parts of the overcurrent tripping devices are replaced. It will be necessary to install a new device when parts are worn or damaged.

### REVERSE CURRENT TRIPPING DEVICE

The device is enclosed in a molded case and is mounted on the right pole base similarly to the series overcurrent tripping device.

The reverse current tripping device (see Fig. 17) consists of a series coil (2) with an iron core mounted between two pole pieces (9), also a potential coil (7) connected across a constant source of voltage and mounted around a rotary-type armature (10). Calibration spring (6) determines the armature pick-up when a reversal of current occurs.

As long as the flow of current through the breaker is in the normal direction, the magnetic flux of the series coil and the magnetic flux of the potential coil produce a torque which tends to rotate the armature counter-clockwise. The calibration spring also tends to rotate the armature in the same direction. This torque causes the armature to rest against the stop screw (12) attached to bearing plate on the right side of the device.

If the current through the series coil (2) is reversed, the armature (10) tends to move in the clockwise direction against the restraint of the

Fig. 16 (2150180)

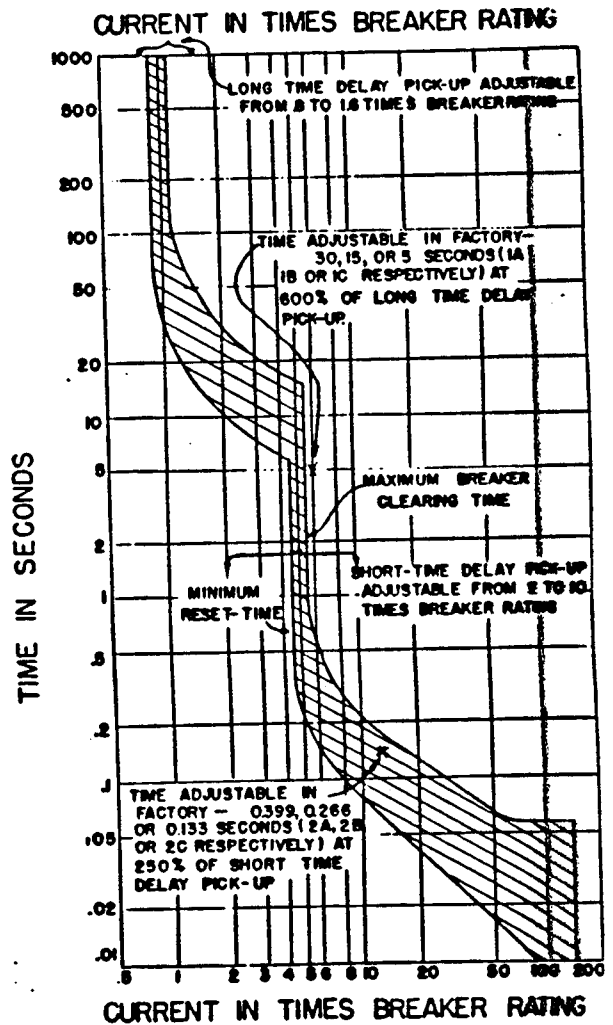
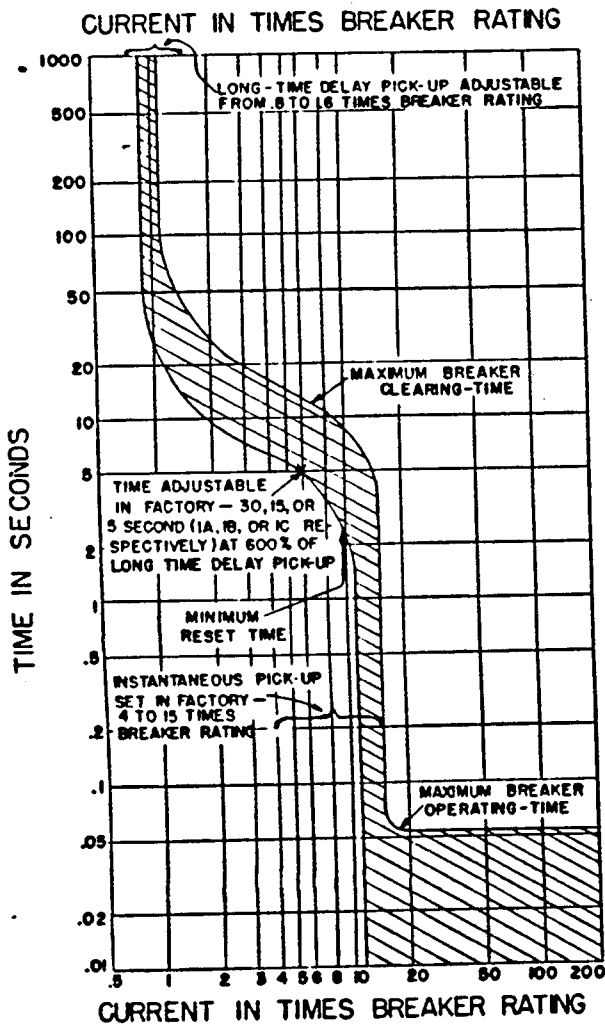
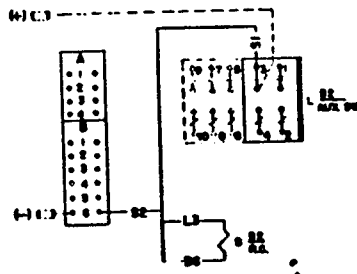
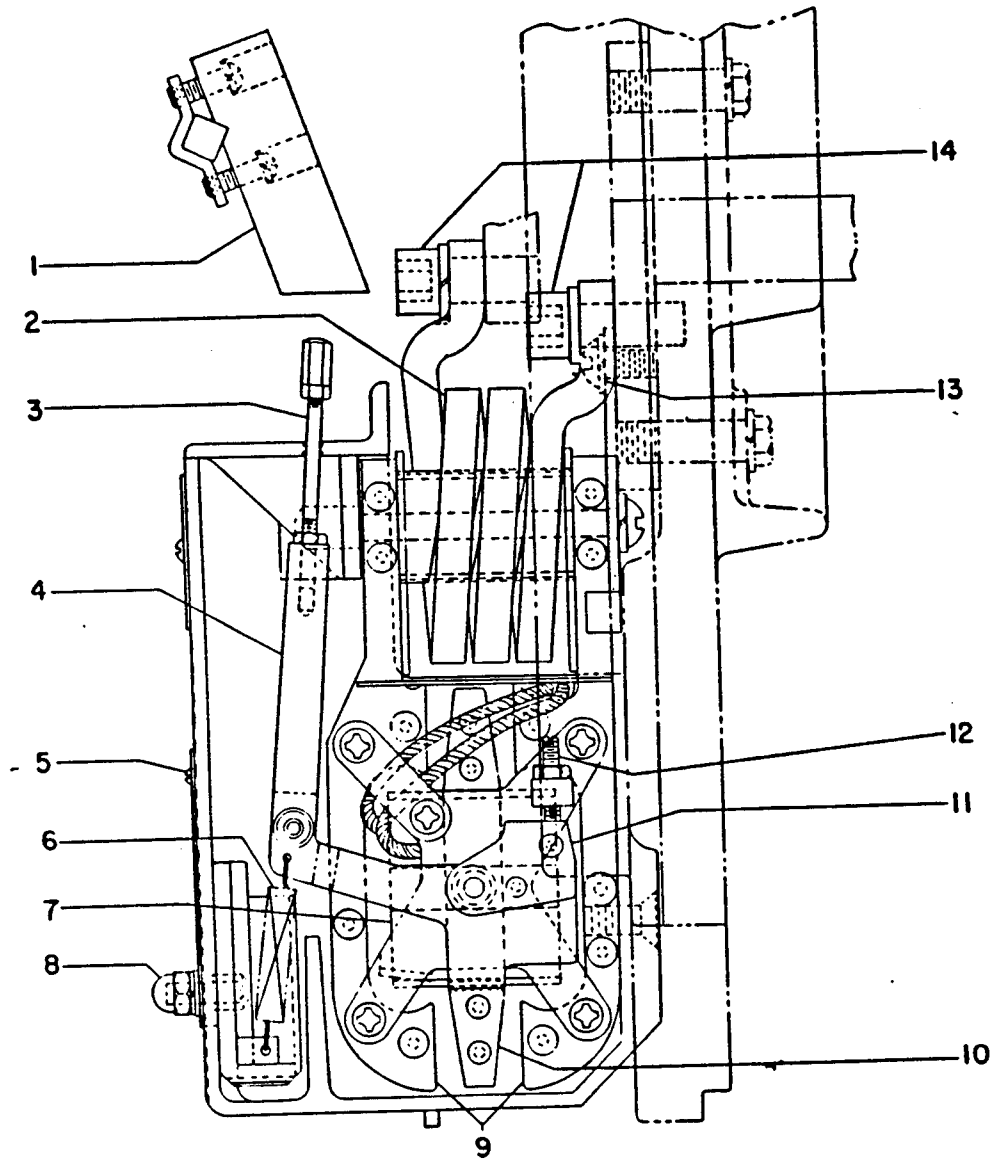

Fig. 16 Typical Time-Current Characteristic



- |                          |                    |                    |
|--------------------------|--------------------|--------------------|
| 1. Trip Paddle           | 6. Spring          | 11. Counter Weight |
| 2. Series Coil           | 7. Potential Coil  | 12. Stop Screw     |
| 3. Trip Rod              | 8. Calibration Nut | 13. Mounting Screw |
| 4. Trip Crank            | 9. Pole Pieces     | 14. Screw          |
| 5. Setting Sealing Screw | 10. Armature       |                    |

Fig. 17 Reverse Current Tripping Device

calibration spring (6). When the current reversal exceeds the calibration setting, the armature revolves clockwise causing the trip rod (3) to move upward engaging the trip paddle (1), thereby tripping the breaker.

**ADJUSTMENTS, FIG. 17**

No adjustments should be made in the field with the exception of checking for overtravel of the trip rod. Proper overtravel of the trip rod is provided, if the trip rod advances the trip paddle between 1/32" to 3/64" beyond the point where the breaker trips. To adjust for this amount of overtravel, lift the trip rod as high as possible after backing off the adjusting nut on the trip rod (3) so that it will not touch the trip paddle (1). Advance

adjusting nut on the trip rod until you can just trip the breaker by lifting the trip rod (3) as far as will go. Then advance this same adjusting nut a additional 1-1/2 turns, thereby assuring positive tripping. Lock adjusting nut.

Be extremely cautious not to have hands near moving parts of the breaker when making this adjustment.

**REPLACEMENT**

After removing the wiring for the potential coil the reverse current device can be removed and replaced by following the procedure outlined for replacing the series overcurrent device. For wiring, see Fig. 17.

**MISCELLANEOUS**

**SHUNT TRIPPING DEVICE**

The shunt tripping device (refer to Fig. 18) is mounted on a bracket attached to the left side of the operating mechanism (looking from the front).

A remote switch or relay contacts are used to close the circuit of the device causing the armature (9) to engage the trip paddle (11), thereby tripping the breaker. The spring (2) is used to return the armature to the neutral position after the breaker trips.

To prevent overheating, the coil (7) is cut off by contacts of the auxiliary switch which are open when the breaker is open.

**ADJUSTMENTS**

From 1/32" to 1/16" overtravel of the armature is required when the breaker is tripped. If an adjustment is necessary to provide this amount of overtravel, the trip lever is bent in or out accordingly.

**REPLACEMENT - COIL (7), FIG. 18**

1. Disconnect leads to coil.
2. Remove magnet (6) and coil from frame (3)
3. Bend lower end of clamp (8) straight and remove.
4. Remove coil and install new coil in reverse order.

Fig. 18 (2150176)

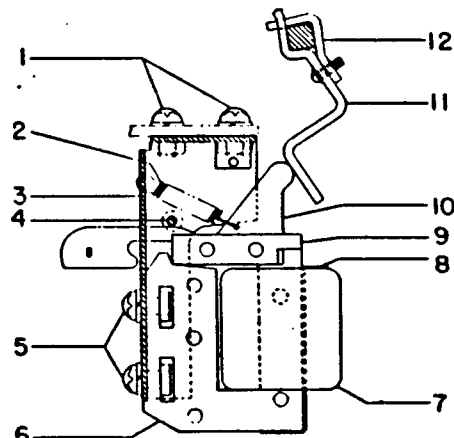
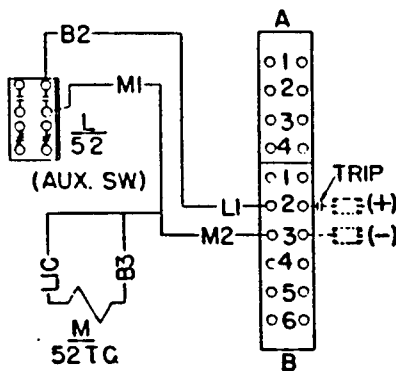

- |           |           |             |                  |
|-----------|-----------|-------------|------------------|
| 1. Screws | 4. Pin    | 7. Coil     | 10. Armature Arm |
| 2. Spring | 5. Screws | 8. Clamp    | 11. Trip Paddle  |
| 3. Frame  | 6. Magnet | 9. Armature | 12. Clamp        |

Fig. 18 Shunt Tripping Device

AJN

## BELL ALARM AND LOCKOUT DEVICE

Refer to Fig. 19. When the breaker is tripped by an overload device, auxiliary shaft (9) rotates counter clockwise causing latch (8) to move off of latch arm (5). The breaker opens causing prop (3) to rotate clockwise allowing switch (2) to close. The switch then rotates latch arm (5), which, in turn allows catch (11) to move downward thereby locking latch arm (5) in the rotated position. When in the rotated position the latch arm keeps the trip shaft and prop (3) in the trip-free position, thus keeping the breaker from being closed until the lockout mechanism is reset by means of reset button (1). When the switch is closed it sounds an alarm. If the breaker is tripped by any device other than an overload device, latch (8) keeps latch arm (5)

from rotating and therefore stops the bell alarm and lockout device mechanism from operating.

### ADJUSTMENTS

1. With the breaker mechanism and lockout mechanism in the reset position adjusting screw (13) should be set so that auxiliary shaft (9) clears the overload paddles on the trip shaft by  $1/32"$  to  $3/32"$ .
2. With the front frame assembled to the back frame the adjusting screws in the series overcurrent tripping devices should be adjusted so that there is approximately  $1/32"$  overtravel after the overload device trips the breaker. See item 4 under "Series Overcurrent Device," "Replacements."

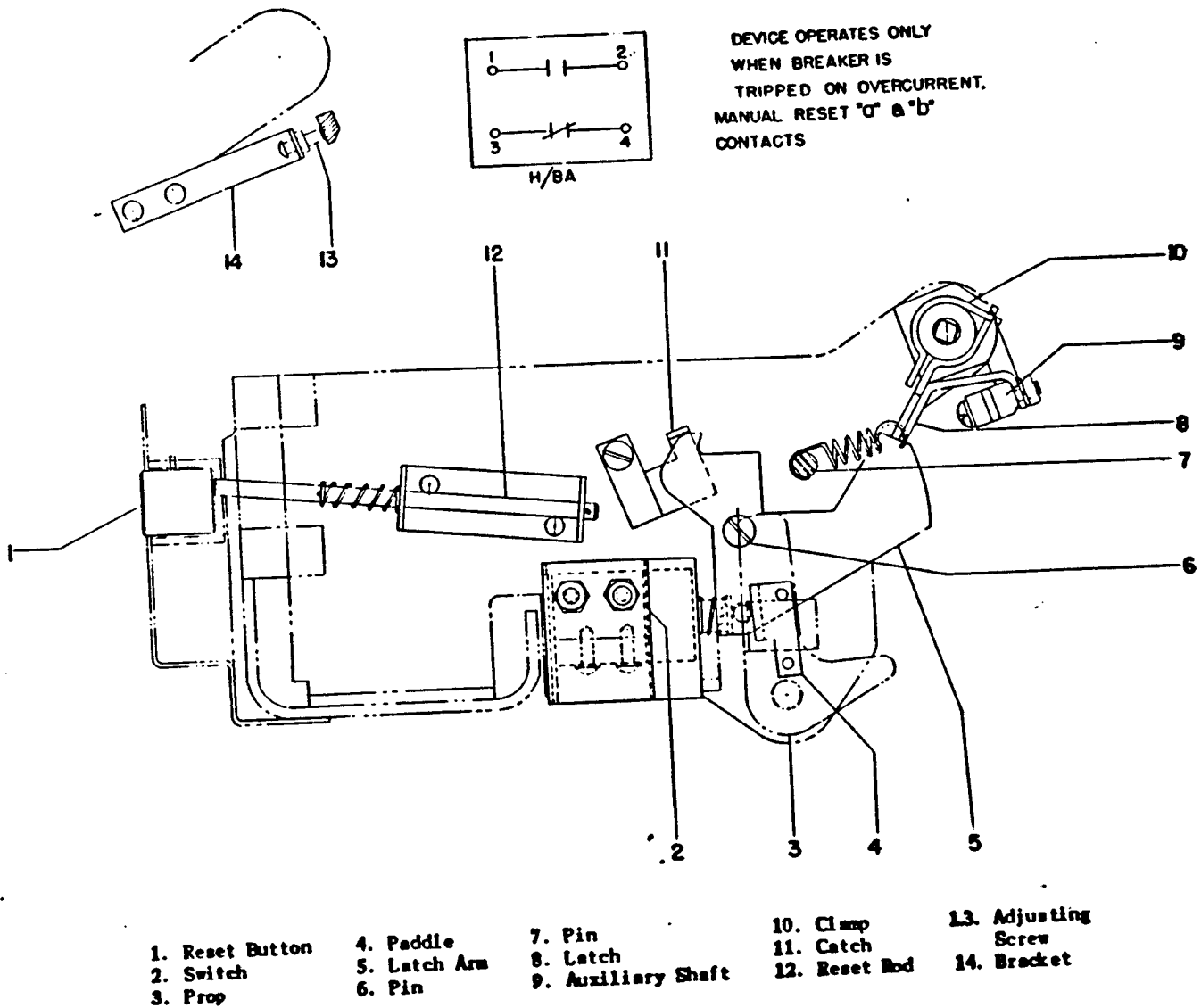

Fig. 19 Bell Alarm And Lockout Device



## DISCONNECTS

The disconnects are attached to the circuit breaker studs at the rear of the breaker.

Each disconnect consists of eight contact fingers (5), four retainers (7), two spacers (4), two screws (1), one retaining ring (6), four washers (2) and four springs (3). The parts are assembled as shown in Fig. 20.

### ADJUSTMENTS, FIG. 20

Tighten the nuts on screw (1) compressing springs (3) so that the spring length from retainer to washer does not exceed 1-1/32 inches.

### LUBRICATION

Grease contact fingers (5) with General Electric Company grease specification D50H28.

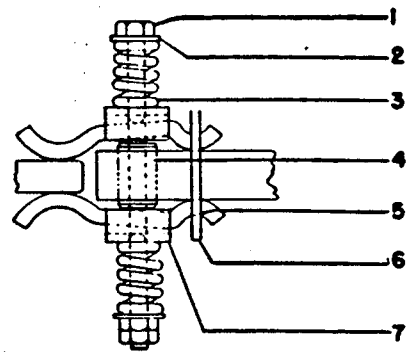

- |           |           |                   |                   |
|-----------|-----------|-------------------|-------------------|
| 1. Screw  | 3. Spring | 5. Contact Finger | 6. Retaining Ring |
| 2. Washer | 4. Spacer |                   | 7. Retainer       |

Fig. 20 Secondary Disconnect

## RENEWAL PARTS

When ordering renewal parts, address the nearest Sales Office of the General Electric Company, specifying the quantity required. The parts should be described and the complete nameplate data of the breaker should be given.

Renewal parts, which are furnished, may not be identical with the original parts since improvements are made from time to time. Parts which are furnished will be interchangeable.

Fig. 20 (26782)



INSTRUCTIONS

# Switchgear

## AIR CIRCUIT BREAKERS

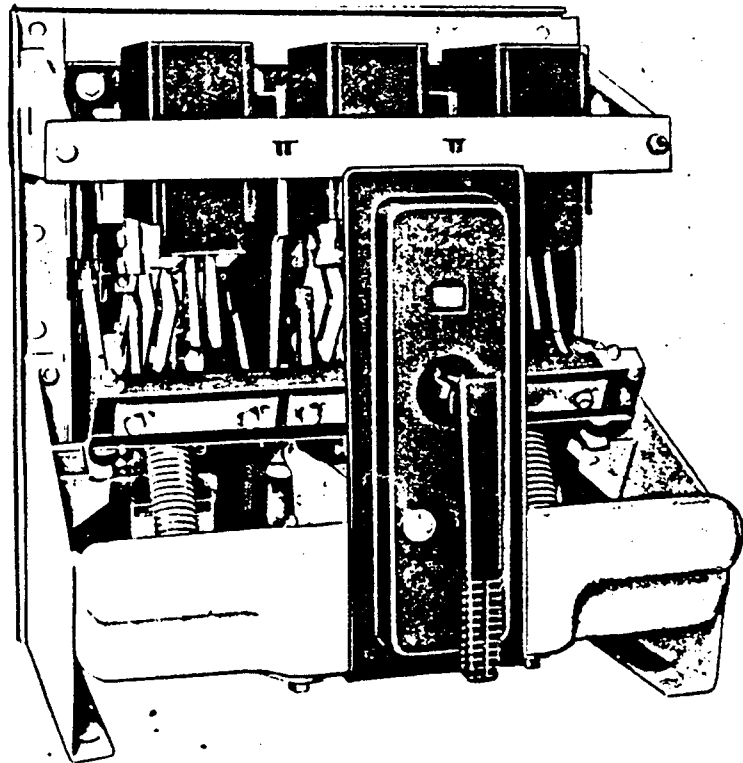

Type AK-1-50-1  
Manually Operated

GENERAL  ELECTRIC

# CONTENTS

	PAGE
INTRODUCTION . . . . .	3
RECEIVING, HANDLING, AND STORAGE . . . . .	3
INSTALLATION . . . . .	3
LOCATION . . . . .	3
MOUNTING . . . . .	3
CONNECTIONS . . . . .	3
OPERATION . . . . .	4
MAINTENANCE . . . . .	4
INSPECTION . . . . .	4
REPAIR AND REPLACEMENT . . . . .	4
TROUBLE SHOOTING . . . . .	5
BASIC BREAKER COMPONENTS . . . . .	5
ARC QUENCHER . . . . .	5
POLE UNIT ASSEMBLY . . . . .	5
OPERATING MECHANISM . . . . .	9
AUXILIARY SWITCH . . . . .	10
PROTECTIVE DEVICES . . . . .	10
TIME DELAY UNDERVOLTAGE TRIPPING DEVICE . . . . .	10
INSTANTANEOUS UNDERVOLTAGE TRIPPING DEVICE . . . . .	11
SERIES OVERCURRENT TRIPPING DEVICE . . . . .	12
REVERSE CURRENT TRIPPING DEVICE . . . . .	14
MISCELLANEOUS . . . . .	15
SHUNT TRIPPING DEVICE . . . . .	15
BELL ALARM AND LOCKOUT DEVICE . . . . .	17
DISCONNECTS . . . . .	17
RENEWAL PARTS . . . . .	17

*These instructions do not purport to cover all details or variations in equipment nor to provide for every possible contingency to be met in connection with installation, operation or maintenance. Should further information be desired or should particular problems arise which are not covered sufficiently for the purchaser's purposes, the matter should be referred to the General Electric Company.*

# AIR CIRCUIT BREAKER

## TYPE AK-1-50-1, MANUALLY OPERATED

### INTRODUCTION

Before unpacking, installing, or attempting to operate the Type AK-1-50-1 Air Circuit Breaker described herein, these instructions should be thoroughly and carefully read.

The ratings for the AK-1-50-1 are as follows:

Continuous Current Rating	Interrupting Rating	Voltage	
		AC	DC
RMS Amperes	RMS Amperes		
15* to 1600	50,000	600	250

\*The interrupting rating is limited on the lower rated coils.

These circuit breakers are generally used for protection and control of apparatus and branch circuits, including equipment in buildings, industries, power stations and for marine applications within the ratings designated.

The AK-1-50-1 breaker for D.C. applications differs from the breaker used for A.C. applications. The difference in D.C. breaker is an extra arcing contact per pole with a corresponding difference in the upper stud and interrupter.

These instructions apply to breakers used for both D.C. and A.C. applications.

### RECEIVING, HANDLING AND STORAGE

Immediately upon receipt of the circuit breaker, an examination should be made for any damage or loss sustained in transit. If injury or rough handling is evident, a damage claim should be filed at once with the transportation company and the nearest General Electric Sales Office should be promptly notified.

The circuit breaker should be unpacked as soon as possible after being received as difficulty may be experienced in making claim for damage, not evident upon receipt, if delayed. Care should be used in unpacking to avoid damaging any of the breaker parts. Be sure that no loose parts are

missing or left in the packing material. Blow out any dirt or particles of packing material that may have accumulated on the breaker parts.

If the circuit breaker is not installed at once, it should be stored in a clean dry place and preferably placed in a vertical position. It should be supported to prevent bending of studs or damage to the breaker parts. It is advisable not to cover the breaker with any packing or other material that absorbs moisture which may cause corrosion of breaker parts. A covering of paper will prevent dust from settling on the breaker parts.

### INSTALLATION

#### LOCATION

The Air Circuit Breaker should be installed in a clean dry place where it is readily accessible for operation, inspection and proper maintenance. Special enclosures are available for the installation of circuit breakers which may be subjected to dust and moisture or other unfavorable locations.

#### MOUNTING

Dead front circuit breakers are designed for mounting in a switchboard or an enclosing case. The mounting of dead front breakers consists of placing the breakers within the enclosed structure and connecting the power buses or cables and making the necessary control connections. The standard mounting depth from the back surface of the breaker base to the back side of the front panel

is 16". The front cover of dead front breakers consists either of a hinged door with cut-out or a plate bolted to the panel.

The structural surface to which the breaker is bolted must be flat throughout and the supporting structure must be of sufficient strength to hold the breaker firmly in place. Minimum cutout dimensions must be maintained in order to have proper electrical clearance.

#### CONNECTIONS

The connections to the circuit breaker studs should be firmly clamped or bolted in place to prevent excessive heating. The connecting cables or bus bars should have a current-carrying capacity specified to limit their temperature rise to that specified for the breakers. If these connecting

cables or bus bars are not of sufficient size, heat will be conducted from them to the breaker so that the breaker cannot carry normal current without exceeding the specified temperature rise.

Connecting cables or bus bars should be supported so that the breaker studs will not be subjected to unnecessary strains.

## OPERATION

The circuit breaker is closed manually by an operating handle. To close the breaker the operating mechanism must be reset, this is accomplished by rotating the operating handle 165° counter clockwise. The breaker is then closed by rotating the operating handle 165° clockwise. The breaker may

be tripped manually by pushing a trip button located in the front escutcheon, or automatically by any tripping device with which the breaker is equipped. After the breaker is tripped it cannot be closed again until the operating mechanism is reset.

## MAINTENANCE

### INSPECTION

BEFORE INSPECTION OR ANY MAINTENANCE WORK IS DONE, BE SURE THAT THE BREAKER IS IN THE OPEN POSITION. ALL ELECTRICAL POWER, BOTH PRIMARY AND CONTROL SOURCES, SHOULD ALSO BE DISCONNECTED.

Periodic inspection of the circuit breaker is recommended at least once a year. More frequent inspections are recommended, if severe load conditions, dust, moisture or other unfavorable conditions exist. A complete inspection of the breaker, including contacts and arc quenchers, should always be made after the breaker has opened a severe short circuit.

After the breaker has been installed, as well as at the regular inspection periods, slowly operate it manually several times as described above and observe whether the contacts line up properly and make sure that all parts move freely without binding or excessive friction.

If the breaker remains open or closed for a period of six months or more it is recommended that arrangements be made to open and close it several times in succession, preferably under load.

If overheating, not caused by overcurrent, is observed, a complete inspection of the breaker should be made including connections, contacts and flexible connectors.

At all times it is important not to allow pencil lines, paint, oil or other foreign materials on the insulating surfaces of the breaker as they may cause low resistance between points of different potential and result in eventual electrical breakdown.

The contacts should be inspected at the regular inspection periods and always after a known

severe short circuit has been opened, to ascertain whether the contacts are badly worn or pitted, in which case they should be dressed or replaced. It is necessary to remove the arc quenchers in order to properly inspect the contacts.

### LUBRICATION

In general, the circuit breaker requires little lubrication. Bearing points and sliding surfaces should be lubricated at the regular inspection periods with a thin film of G.E. Lubricant D50H15. Hardened grease and dirt should be removed from latch and bearing surfaces by using kerosene. ALL EXCESS LUBRICANT SHOULD BE REMOVED WITH A CLEAN CLOTH IN ORDER TO AVOID ANY ACCUMULATION OF DIRT OR DUST.

The use of cotton waste to wipe bearing surfaces should be avoided, as the cotton ravelings might become entangled under the bearing surfaces and destroy the surface of the bearing.

## REPAIR AND REPLACEMENT

In order to replace contacts, operating mechanism or series overcurrent tripping devices, the front frame must be separated from the back frame. To separate the two frames proceed as follows:

1. The breaker must be open.
2. Remove the two opening springs from the outside pole units.
3. Remove the clevis pin, (14) Fig. 2.
4. Remove the four bolts from the back frame by using a socket wrench with an extension. The two frames can now be separated.

**NOTE:** It is recommended that the breaker be fastened to a suitable mounting base with a sling or hook to hold the front frame as the bolts are being removed.

## TROUBLE SHOOTING

<u>TROUBLE</u>	<u>PROBABLE CAUSE</u>	<u>REMEDY</u>
Overheating	<p>Contacts not aligned.</p> <p>Contacts dirty, greasy or coated with dark film.</p> <p>Contacts badly burned or pitted.</p> <p>Current carrying surfaces dirty.</p> <p>Bolts and nuts of points at terminal connection not tight.</p> <p>Current in excess of breaker rating.</p> <p>Excessive ambient temperature.</p>	<p>Adjust contacts.</p> <p>Clean contacts.</p> <p>Replace contacts.</p> <p>Clean surfaces of current carrying parts.</p> <p>Tighten, but do not exceed elastic limit of bolts or fittings.</p> <p>Decrease load, rearrange circuit or install larger breaker.</p> <p>Provide adequate ventilation.</p>
Failure to Trip	<p>Travel of tripping device does not permit positive release of tripping latch.</p> <p>Worn or damaged trip unit parts.</p>	<p>Re-adjust or replace device.</p> <p>Replace Trip Unit.</p>
False Tripping	<p>Binds in overload device.</p>	<p>Replace overload device.</p>
Failure to close and latch.	<p>Binding in attachments preventing resetting of latch.</p> <p>Chipped or worn latch.</p> <p>Latch out of adjustment.</p> <p>Latch return spring too weak or broken</p> <p>Hardened or gummy lubricant</p>	<p>Re-align and adjust attachments.</p> <p>Replace latch.</p> <p>Adjust latch.</p> <p>Replace spring.</p> <p>Clean bearing and latch surfaces.</p>

## BASIC BREAKER COMPONENTS

## ARC QUENCHER

The arc quenchers should be inspected at the regular inspection period and if the barriers are cracked or eroded, they should be replaced.

## REPLACEMENT

1. Remove the channel shaped retaining bar by removing two screws.
2. Lift the quencher clear of the movable arcing contacts.
3. During replacement be careful not to overtighten the screws which secure the channel shaped retaining bar. Overtightening the screws will bow the bar and leave the center arc quencher loose.

INSPECTING INNER, SLIDE, AND POCKET BARRIERS, FIG. 1.

1. Remove arc quenchers (see above).
2. Remove screws holding spacer block (8).
3. Remove spacer block, steel backplate (7) and compound support (6).
4. Slide muffler (5) from slot and remove. The inner barriers (4) can now be removed for inspection.
5. Remove nut and withdraw stud from cap (1).
6. Remove cap (1). The side (2) and pocket (3) barriers can now be removed.
7. Re-assemble and replace the arc quenchers in the reverse order. Tighten all fastenings after replacement.

## POLE UNIT ASSEMBLY

Each pole unit assembly consists of a set of arcing contacts, a set of main contacts, the operating linkage and the mounting base. See Fig. 2.

GEH-1799 Type AK-1-50-1 Air Circuit Breaker

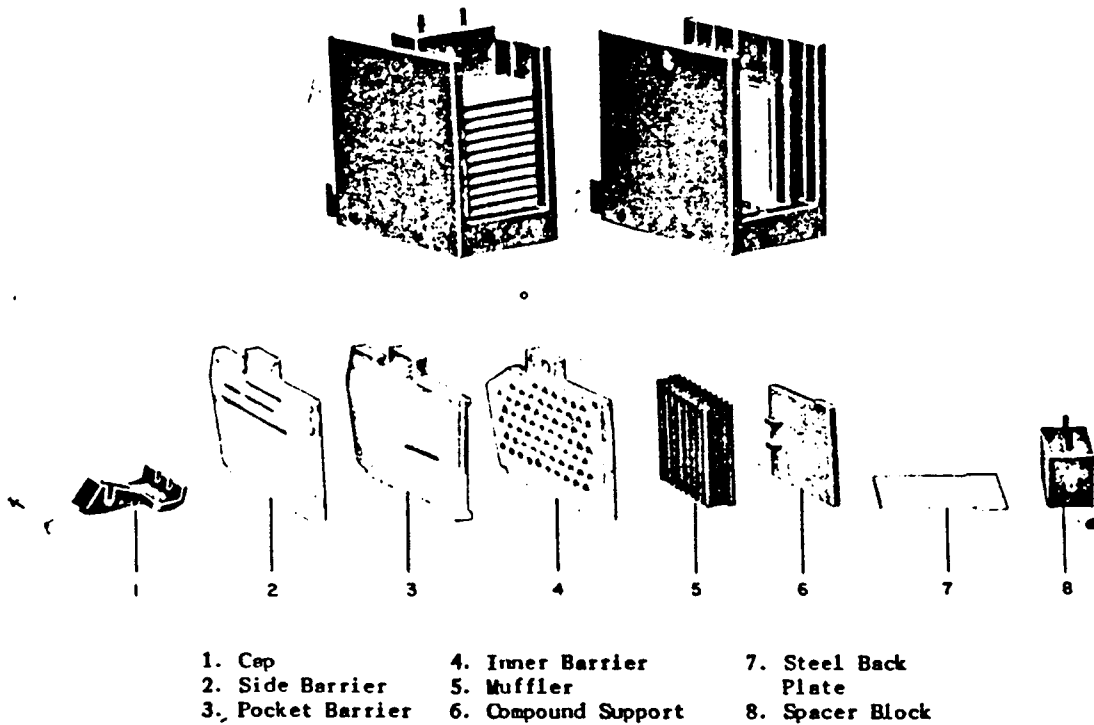

Fig. 1 Dis-Assembly of Arc Quencher to Inspect, Inner, Side and Pocket Barriers

The stationary arcing contact consists of a set of parallel contact fingers (2), pin (3), and compression springs (22), which provide continuous contact pressure for the full travel of the contacts. Flexible braid leads shunt the pivot pin to prevent possible pitting at the pivot point when interrupting high currents.

The movable arcing contact assembly consists of parallel contact arms (4) carried on two movable pivot pins (8) and (19). The arcing contacts interleaf the main contacts and pivot with them about pin (19). This relative motion is obtained by linkages from the upper pin (7) to the breaker mechanism.

The stationary main contact assembly includes main contacts and intermediate contacts. The intermediate contact surface extends beyond the main contacts and will, therefore, make before the main contacts and break after the main contacts. The number of contacts for each rating is given in Table I.

The movable main contacts pivot around a stationary pin (18), which holds them to the lower block, motion is obtained from a second pin (7), connected by an insulated link (12) to the breaker mechanism. Steel springs (17) force the contacts against the pin to prevent pitting at the pivot point. The movable main contact assembly also contains main and intermediate contacts.

TABLE I

Breaker Type	Main Contacts			Intermediate Contacts			Arcing Contacts		
	No. of Contacts	Pressure lbs.	Wipe in Inches	No. of Contacts	Pressure lbs.	Wipe in Inches	No. of Contacts	Pressure lbs.	Wipe in Inches
AK-1-50-1 For D.C.	3	55-65	1/16-3/32	1	55-65	*	3	25-35	5/16-7/16
AK-1-50-1 For A.C.	3	55-65	1/16-3/32	1	55-65	*	2	25-35	5/16-7/16

\* The intermediate contact wipe should be at least 1/16" more than the main contact wipe.



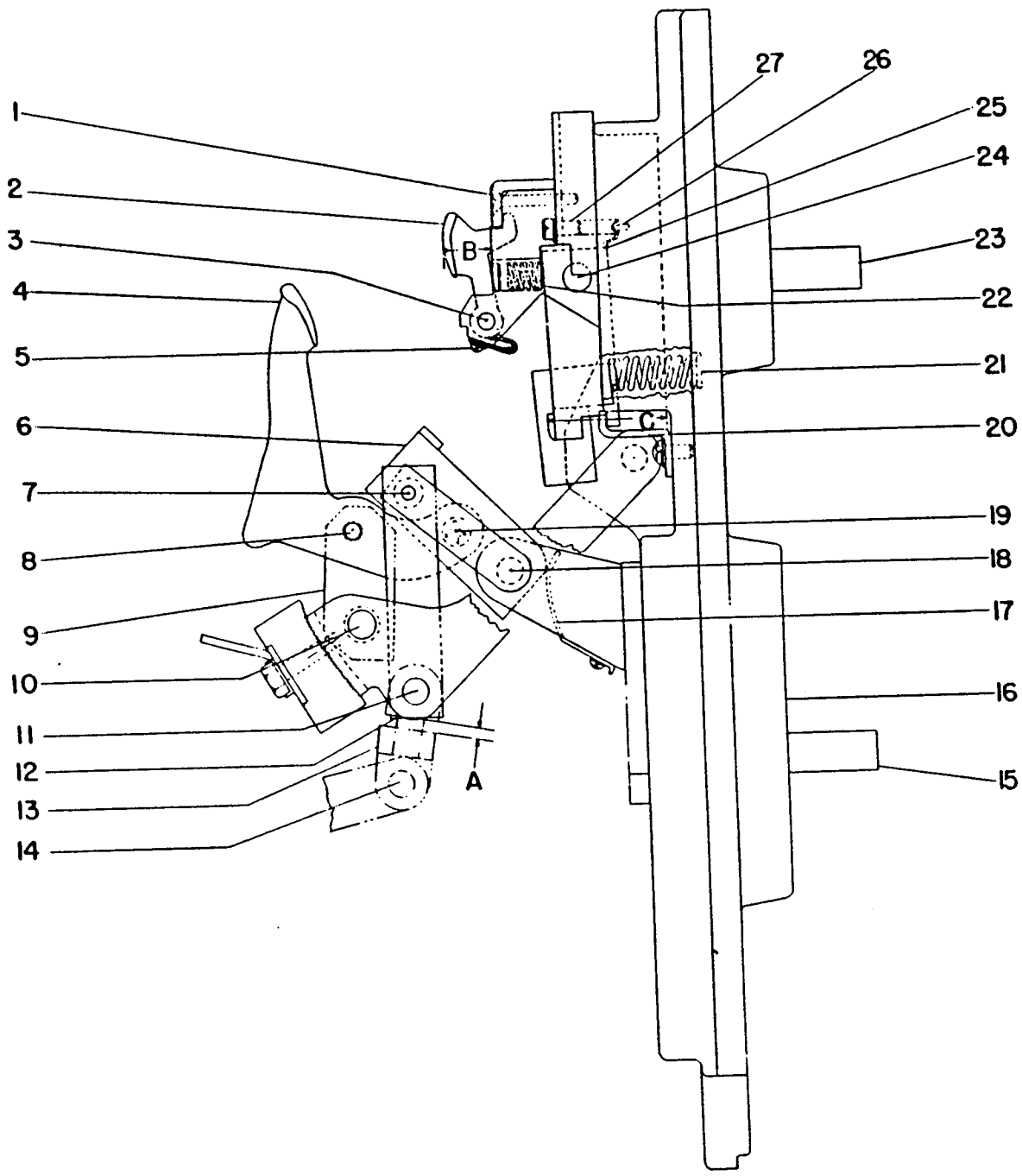

- |                            |                                 |                                |
|----------------------------|---------------------------------|--------------------------------|
| 1. Screw                   | 10. Pin (Insulating Link)       | 19. Pin (Movable Arcing Cont.) |
| 2. Sta. Arcing Contact     | 11. Pin (Side Link)             | 20. Side Link                  |
| 3. Pin (Sta. Arcing Cont.) | 12. Link                        | 21. Spring (Sta. Main Cont.)   |
| 4. Movable Arcing Contact  | 13. Clevis                      | 22. Spring (Sta. Arcing Cont.) |
| 5. Braid                   | 14. Clevis Pin                  | 23. Upper Stud                 |
| 6. Movable Main Contact    | 15. Lower Stud                  | 24. Pin (Sta. Main Cont.)      |
| 7. Shouldered Pin          | 16. Pole Unit Base              | 25. Stationary Main Contact    |
| 8. Pin (Arcing Cont. Link) | 17. Spring (Main Movable Cont.) | 26. Screw                      |
| 9. Insulating Link         | 18. Pin (Movable Main Cont.)    | 27. Screw                      |

Fig. 2 Pole Unit Assembly

In order to function properly, a definite amount of contact pressure and contact wipe must exist between the movable and stationary contacts. Table I gives the figures for contact wipe and contact pressure. Both wipe and pressure should be checked during the regular inspection period.

**MEASURING CONTACT PRESSURE, FIG. 2**

1. Remove arc quenchers, (see replacements under "Arc Quenchers").
2. With the breaker open, measure the "B" dimension of the stationary arcing contact with the spring (22) full compressed. Place a push-type scale against the stationary arcing contact and push the contact backward until the "B" dimension is 1/16" more than the measurement taken in item 2. The scale should then be read.

**MEASURING CONTACT WIPE, FIG. 2**

1. Remove the arc quencher.
2. With the breaker open, measure the horizontal distance from the edge of the contact to the surface behind it. ("B" and "C" dimensions).
3. Close the breaker and repeat item 2. The difference between the readings in item "2 and 3" determines the wipe of the contacts. For safety reasons be extremely careful not to trip the breaker.

**ADJUSTING CONTACT WIPE AND PRESSURE, FIG. 2**

1. With the breaker open, measure dimension "A".
2. Remove the clevis pin (14) and increase dimension "A" to increase the wipe, and decrease dimension "A" to decrease the wipe by turning the clevis (13).

**NOTE:** If the proper contact pressure does not exist when the contact wipe is within its limits, the stationary contact springs should be replaced.

**REPLACEMENT, FIG. 2**

1. Remove the upper plate by removing two screws (1).
2. Remove screw from braid (5).
3. Remove pin (3) allowing the stationary contacts and spring (22) to fall free.
4. Install new springs and stationary arcing contacts in reverse order.
5. Adjust contact wipe and pressure (see "Adjusting Contact Wipe and Pressure").

**MOVABLE ARCING CONTACTS (4)**

The movable arcing contacts should be replaced when the stationary arcing contacts are replaced.

1. Separate the front frame from the pole unit frame (see "Repair and Replacement").

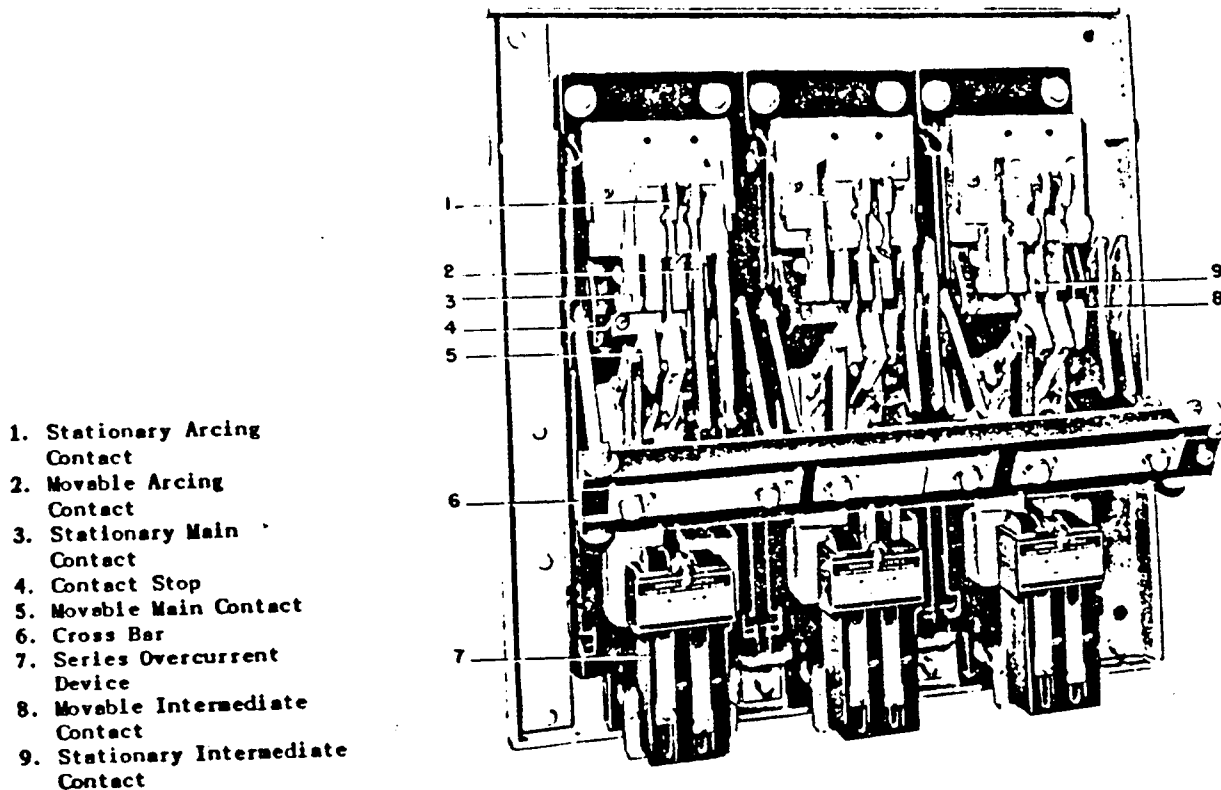

Fig. 3 Front View of Back Frame Assembly

2. Remove pins (8) and (19) and withdraw the contacts.
3. Re-assemble parts in the reverse order.

**STATIONARY INTERMEDIATE CONTACTS (9), FIG. 3**

1. Remove screws (27) and remove bracket which holds pin (24) in place. See Fig. 2.
2. Remove clamp which holds lower part of stationary contact.
3. Remove pin (24) and screws (26).
4. Lift out the intermediate contacts.
5. Replace the contacts remembering to match the intermediate contacts on each pole.
6. Re-assemble in the reverse order.

**MOVABLE INTERMEDIATE CONTACTS (8), FIG. 3**

1. Remove the movable arcing contacts as described above.
2. Loosen spring (17). See Fig. 2.
3. Slide link (12) to the side and off of pin (7).
4. Slide pins (18) and (7) far enough to the side to allow the movable intermediate contact to be replaced.
5. Reassemble parts in reverse order.

Always check the contact wipe and pressure following contact replacement.

**OPERATING MECHANISM**

The operating mechanism is supported in a

"U" shaped steel frame in front of the center pole unit. It consists of a cam (5), linkage (6), prop (7), roller latch (10), trip latch and shaft (11). Refer to Fig. 4.

The breaker is closed by rotating the operating handle 165° counter-clockwise which allows cam reset spring (17) to pull the cam (5) into the reset position. The handle is then turned 165° clockwise thereby causing roller (4) to engage cam (5) thus causing the linkage to straighten, which moves the cross bar (6) Fig. 3, and movable contacts to the closed position.

The breaker mechanism is tripped by rotating the trip shaft and releasing trip latch (11) which causes the linkage to collapse, allowing the opening springs to pull the cross bar and movable contacts to the open position. The mechanism does not reset until the operating handle is rotated 165° counter-clockwise. Latch stop (12) limits the rotation of the trip shaft and thus determines the amount of latch engagement.

**ADJUSTMENTS, FIG. 4**

With the breaker open the latch adjustments are as follows:

Latch clearance -

1. Reset the mechanism by turning the operating handle 165° counter-clockwise.

1. Position Indicator
2. Prop
3. Spring
4. Closing Roller
5. Closing Cam
6. Link
7. Prop
8. Prop Adjusting Screw
9. Reset Spring
10. Roller Latch
11. Trip Latch
12. Stop
13. Spacers
14. Clevis
15. Extension
16. Gear
17. Spring

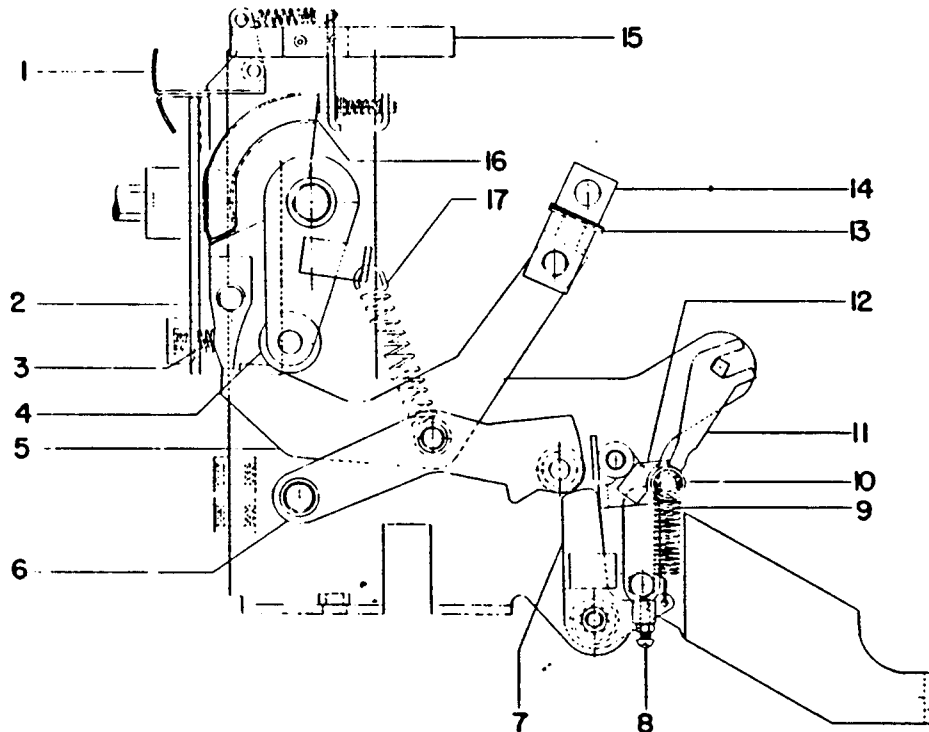

Fig. 4 Operating Mechanism

## GEH-1799 Type AK-1-50-1 Air Circuit Breaker

2. The vertical clearance between the trip latch (11) and roller (10) should be  $1/64''$  to  $1/32''$ .
3. To obtain this clearance the adjusting screw (8) is turned. Be certain the nut is tightened on the adjusting screw (8) after obtaining proper clearance.

### Latch engagement -

1. Mechanism in reset position.
2. Form stop (12) until center line of trip latch (11) passes through the center of roller (10).

### REPLACEMENTS, FIG. 4

Prop reset spring (9) - unhook and replace.  
Cam reset spring (17) - unhook and replace.

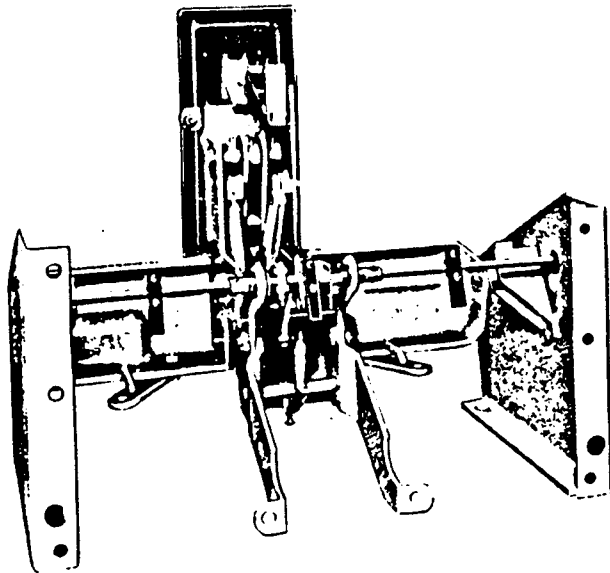
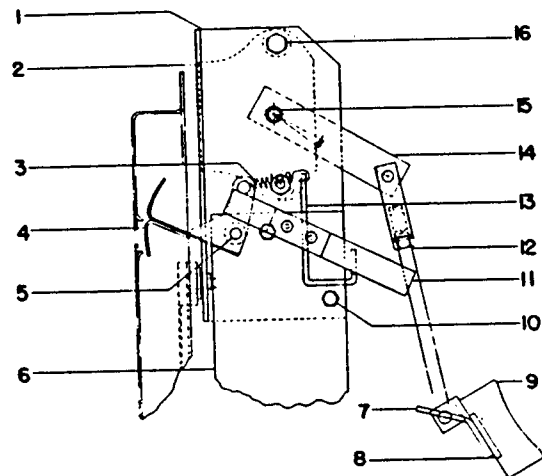

Fig. 5 Rear View of Front Frame Assembly

## AUXILIARY SWITCH

The auxiliary switch is used to make and break various control circuits as the circuit breaker is opened and closed.

The auxiliary switch, refer to Fig. 6, is mounted on the left side of the front frame. As



- |                     |                       |                     |
|---------------------|-----------------------|---------------------|
| 1. Plate            | 7. Indicator Actuator | 12. Operating Rod   |
| 2. Auxiliary Switch | 8. Adjusting Plate    | 13. Bracket         |
| 3. Spring           | 9. Cross Bar          | 14. Link            |
| 4. Indicator        | 10. Bolt              | 15. Operating Shaft |
| 5. Pivot Pin        | 11. Extension         | 16. Bolt            |
| 6. Frame            |                       |                     |

Fig. 6 Auxiliary Switch Linkage

the cross bar (9) moves, with the contacts, to the open or closed position it operates a rectangular link (14) through an operating rod (12). The rectangular link rotates the operating shaft (15) of the auxiliary switch, which, through cams located on this shaft opens and closes the auxiliary switch contacts. The top terminals of the switch are "a" contacts (open when the breaker is open) and the bottom terminals are "b" contacts (closed when the breaker is open).

### REPLACEMENT, FIG. 6

1. Disconnect all leads to auxiliary switch.
2. Remove two mounting bolts (16).
3. Disengage auxiliary switch shaft (15) from the rectangular link (14).
4. Set arrow on new auxiliary switch shaft as shown in Fig. 6.
5. Push auxiliary switch shaft (15) into square hole in link (breaker open).
6. Replace mounting hardware and wiring.

## PROTECTIVE DEVICES

### TIME DELAY UNDERVOLTAGE TRIPPING DEVICE

This device is mounted to a bracket on the left side of the operating mechanism (looking from the front). The purpose of this device is to trip

the breaker for undervoltage. For rated voltage, the armature (3) is attracted by magnet (14). If the voltage falls below the rated value the magnet (14) releases the armature (3). Spring (4) then pulls armature (3) upward against the restraining force of the oil in cylinder (10); this action causes a time delay. When the spring overcomes the restraining

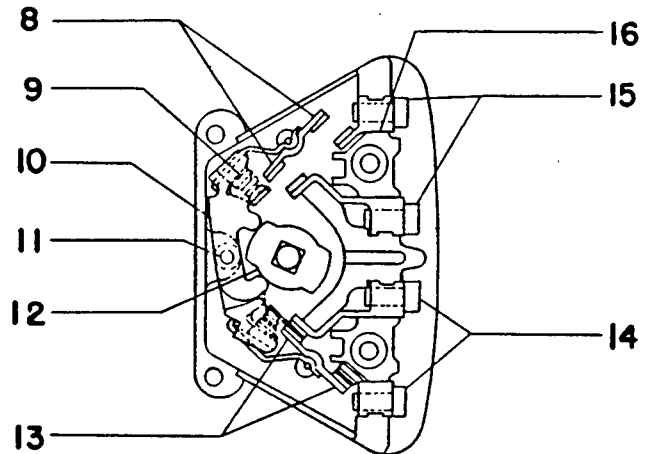
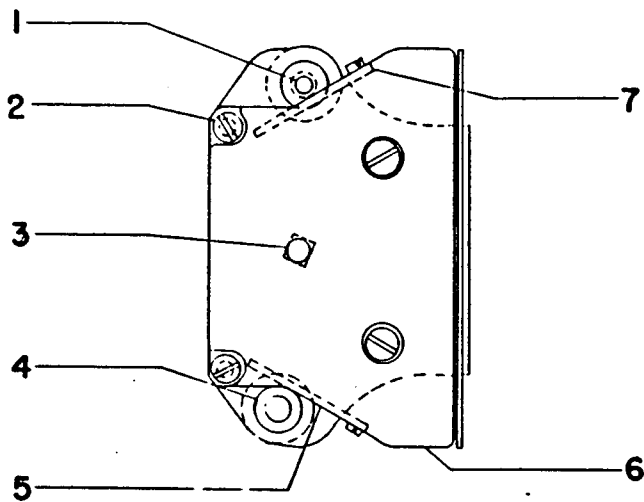

STAGE OF SWITCH SHOWING  
BREAKER IN OPEN POSITION

- |                  |                 |                   |                   |
|------------------|-----------------|-------------------|-------------------|
| 1. Mounting Bolt | 5. Bottom Cover | 9. Contact Spring | 13. 'b' Contacts  |
| 2. Tie Bolt      | 6. End Plate    | 10. Rocker Arm    | 14. 'b' Terminals |
| 3. Shaft         | 7. Top Cover    | 11. Pin           | 15. 'a' Terminals |
| 4. Screw         | 8. 'a' Contacts | 12. Cam           | 16. Barrier       |

Fig. 7 Rotary Auxiliary Switch

force of the oil, the armature engages screw (20) thus rotating the trip shaft and opening the breaker. (For parts reference refer to Fig. 8).

#### ADJUSTMENTS, FIG. 8

An adjusting screw (20) in the trip lever is used to allow from 1/32 to 1/16 inch overtravel after tripping the breaker.

Adjusting screw (2) is used to adjust the armature so that it will pick-up at 80% of normal voltage and drop out between 30% and 60% of normal voltage.

Adjusting nut (8) on connecting rod (11) is intended for a minimum amount of adjustment of the time delay setting.

From 1/4 to 3/8 inch of oil should be maintained in the cylinder at all times. In order to make an inspection of the oil, the cylinder may be unscrewed from the cap. G.E. silicone oil 9981LT40NV or similar grade should be used in the cylinder.

#### REPLACEMENTS, - - Time Delay Undervoltage Device, Fig. 8

1. Disconnect coil leads
2. Remove two screws from bracket (1).

(Bracket is omitted when instantaneous undervoltage device is used).

3. Remove four mounting screws (21) and remove device.
4. Install new device in reverse order.

#### Coil (15)

1. Disconnect leads to coil.
2. Remove two screws (16).
3. Remove magnet and coil assembly.
4. Straighten laminations around shading ring (5).
5. Remove shading ring and straighten lower end of coil clamp (13).
6. Remove coil. Install new coil in reverse order.

### INSTANTANEOUS UNDER VOLTAGE TRIPPING DEVICE

The undervoltage tripping device is constructed similarly to the time delay undervoltage tripping device with the exception that the cylinder (10), plunger (12), connecting rod (11), clevis (7), bracket (1) and adjusting nut (8), as shown in Fig. 8 are omitted.

The adjustments and replacement for this device are also the same as those for the time delay undervoltage tripping device.

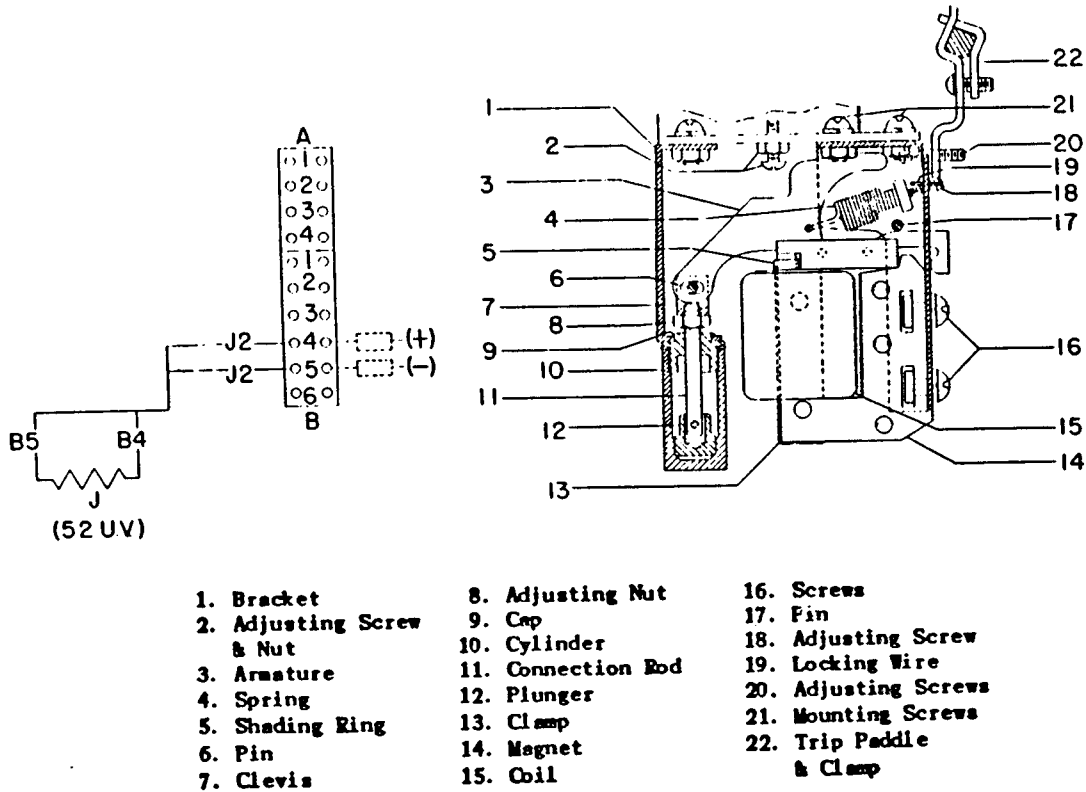

Fig. 8 Time Delay Undervoltage Tripping Device

### SERIES OVERCURRENT TRIPPING DEVICE

Each series overcurrent tripping device is enclosed in a molded case and mounted by three screws and a bracket to the lower part of the pole unit base.

The device can be provided with the following tripping combinations:

1. Long time delay, short time delay and instantaneous tripping.
2. Long time and short time delay tripping only.
3. Long time delay and instantaneous tripping.
4. Short time delay and instantaneous tripping.
5. Short time delay tripping only.
6. Instantaneous tripping.
  - (a) Adjustable
  - (b) Nonadjustable

#### Short Time Delay Tripping, Fig. 9

The armature (7) is retained by calibrating spring (8). After the magnetic force, produced by an overcurrent condition, overcomes this restraining force, the armature movement is further retarded by an escapement mechanism which produces an inverse time delay characteristic. The mechanism is shown on Fig. 9a.

#### Long Time Delay Tripping, Fig. 9

The armature (10) is retained by the calibration spring (11). After the magnetic force, produced by an overcurrent condition, overcomes this restraining force, the armature movement is further retarded by the flow of silicone oil in a dashpot, which produces an inverse time delay characteristic. The mechanism is shown on Fig. 9b.

#### Instantaneous Tripping, Fig. 9

- (a) Adjustable instantaneous tripping takes place after the magnetic force produced by an overcurrent condition, overcomes the restraining force of the calibration spring which can be adjusted by the calibration clamp nut (14).
- (b) Nonadjustable instantaneous tripping takes place after the magnetic force produced by an overcurrent condition overcomes the restraining force of a nonadjustable spring.

Selective tripping is obtained when the breakers in the electrical distribution system are arranged on the basis of a progressive series of time and current pickup. This will allow the breaker having the shorter time setting and the lower pickup to trip before the breaker having the longer time setting and the higher current pickup, provided the fault is on the part of the line protected by the breaker having the lower setting. Hence, if a fault

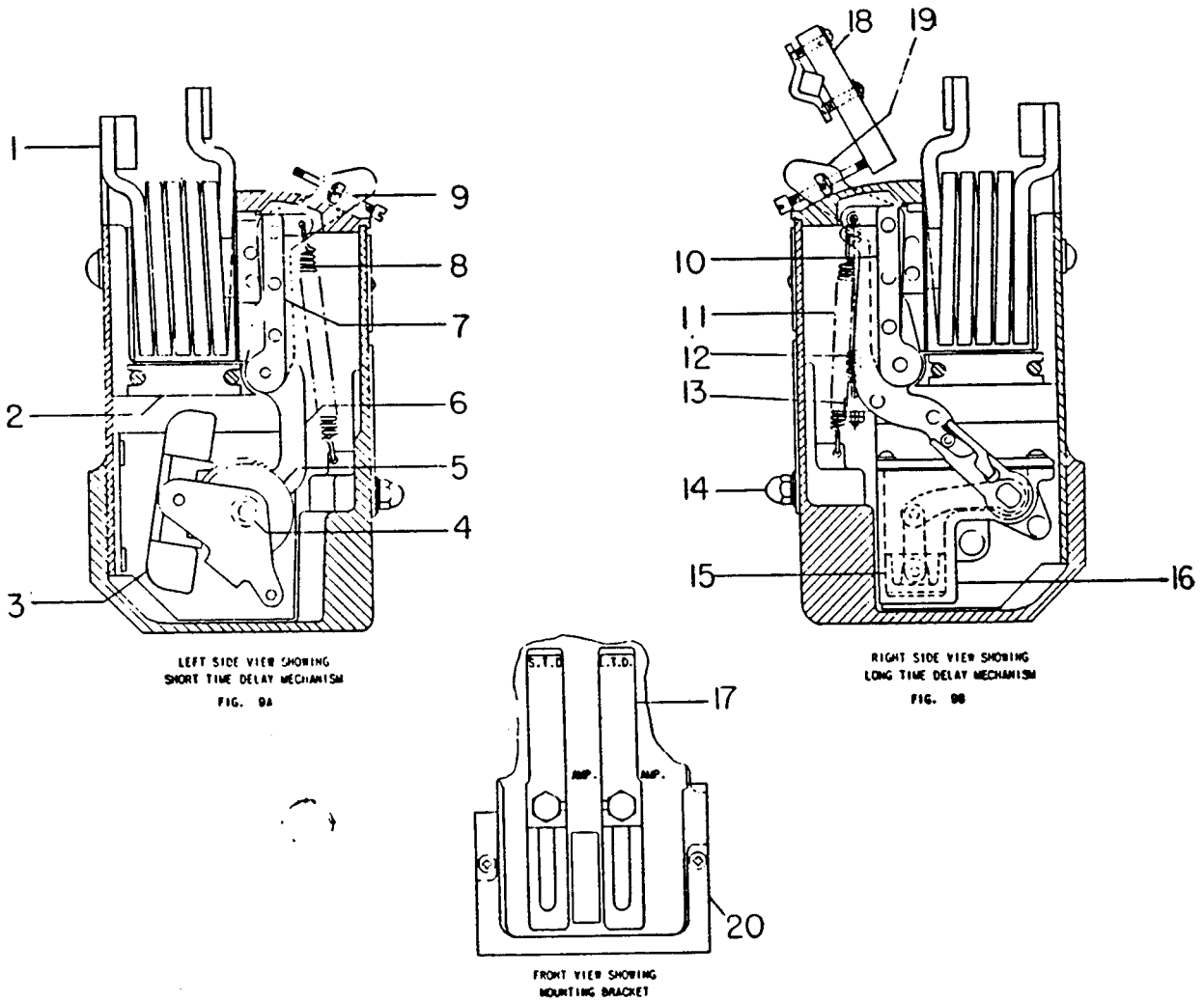

- |                    |                               |                                    |
|--------------------|-------------------------------|------------------------------------|
| 1. Series Coil     | 8. S.T.D. Calibration Spring  | 15. Plunger                        |
| 2. Magnet          | 9. Trip Arm                   | 16. Cylinder                       |
| 3. Pallet          | 10. L.T.D. Armature           | 17. Calibration Plate              |
| 4. Pinion          | 11. L.T.D. Calibration Spring | 18. Trip Paddle                    |
| 5. Escape Wheel    | 12. Instantaneous Trip Spring | 19. Trip Paddle<br>Adjusting Screw |
| 6. Driving Segment | 13. Spring Holder             | 20. Clamping Bracket               |
| 7. S.T.D. Armature | 14. Calibration Clamp Nut     |                                    |

Fig. 9 Series Overcurrent Tripping Device

## GEH-1799 Type AK-1-50-1 Air Circuit Breaker

occurs in any part of the electrical system, only the breaker nearest the fault will trip.

In order to reduce the possibility of damaging the equipment and to provide maximum safety to the operator, the overload caused by a fault is removed in a minimum amount of time by selective tripping. Overloads producing current up to 5 or 10 times the breaker rating are removed in a matter of a few seconds while currents in excess of this value are removed in a fraction of a second.

For the exact characteristics and setting of each breaker in a selective system, reference should be made to the coordination chart furnished for the particular system.

### ADJUSTMENTS, FIG. 9

Calibration clamping nuts (14) are used to set the desired pickup for the adjustable elements.

To adjust for approximately  $1/32$ " overtravel of trip arm (9) after tripping:

1. Check trip latch engagement. See "Adjustments - Operating Mechanism".
2. Loosen the locknut and turn the adjusting screw (19) on the trip arm (9). The screw should not touch the trip paddle when the breaker is "open" and the latch is reset, but should have a clearance not exceeding  $1/32$ ".
3. Tighten the adjusting screw locknut on the trip arm.

### REPLACEMENT

1. Remove front frame (See "Repair and Replacement").
2. Remove the bolts holding the coil to the lower stud.
3. Remove bracket and mounting screws.
4. Before installing a new device, check the travel of the trip arm with a rod or wire and push the armature solidly against the magnet (see Fig. 10). The trip arm should move at least  $5/32$ ". If there appears to be insufficient movement of the trip arm, or if the armature appears to be binding, the device should not be used.
5. Replace new device in reverse order.
6. Adjust device as described above.

**NOTE:** No component parts of the overcurrent tripping device are replaced. It will be necessary to install a new device when parts are worn or damaged.

## REVERSE CURRENT TRIPPING DEVICE

The device is enclosed in a molded case and is mounted on the right pole base similarly to the series overcurrent tripping device.

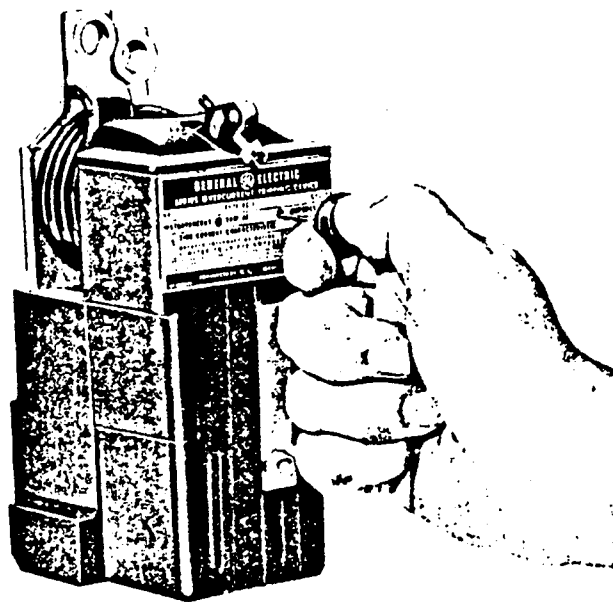

Fig. 10 Checking Travel Distance Of Trip Arm On Overcurrent Trip Device

The reverse current tripping device consists of a series coil (2) with an iron core mounted between two pole pieces (9), also a potential coil (7) connected across a constant source of voltage and mounted around a rotary-type armature (10). Calibration spring (6) determines the armature pick-up when a reversal of current occurs.

As long as the flow of current through the breaker is in the normal direction, the magnetic flux of the series coil and the magnetic flux of the potential coil produce a torque which tends to rotate the armature counter-clockwise. The calibration spring also tends to rotate the armature in the same direction. This torque causes the armature to rest against the stop screw (12) attached to a bearing plate on the right side of the device.

If the current through the series coil (2) is reversed, the armature (10) tends to move in the clockwise direction against the restraint of the calibration spring (6). When the current reversal exceeds the calibration setting, the armature revolves clockwise causing the trip rod (3) to move upward engaging the trip paddle (1), thereby tripping the breaker.

### ADJUSTMENTS

No adjustments should be made in the field with the exception of checking for overtravel of the trip rod. Proper overtravel of the trip rod is provided, if the trip rod advances the trip paddle between  $1/32$ " to  $3/64$ " beyond the point where the breaker trips. To adjust for this amount of overtravel, lift the trip rod as high as possible after backing off the adjusting nut on the trip rod (3) so that it will not touch the trip paddle (1). Advance adjusting nut on the trip rod until you can just trip the breaker by lifting the trip rod (3) as far as it will go. Then advance this same adjusting nut an additional  $1-1/2$  turns, thereby assuring positive



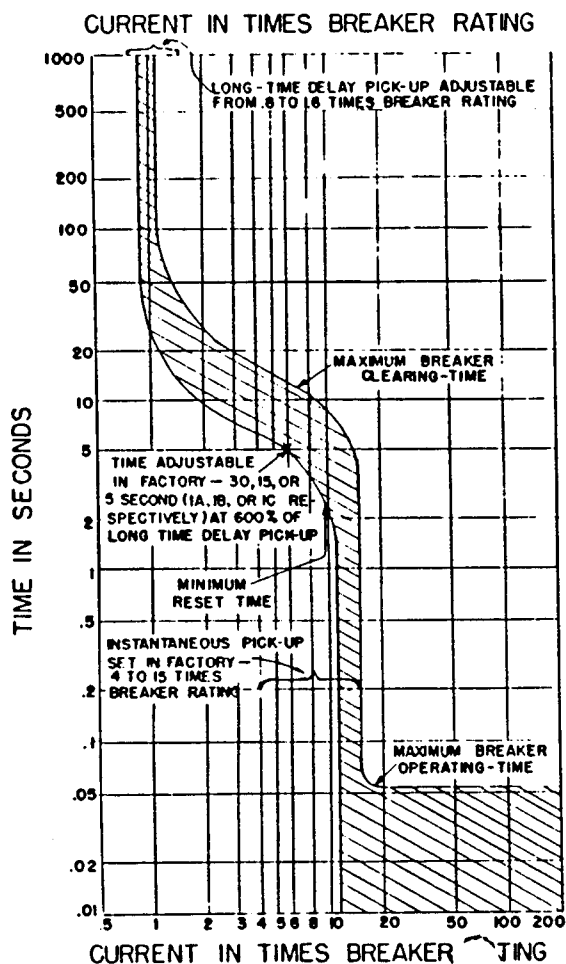

FIG. IIA  
LONG-TIME AND INSTANTANEOUS  
TRIPPING CHARACTERISTIC

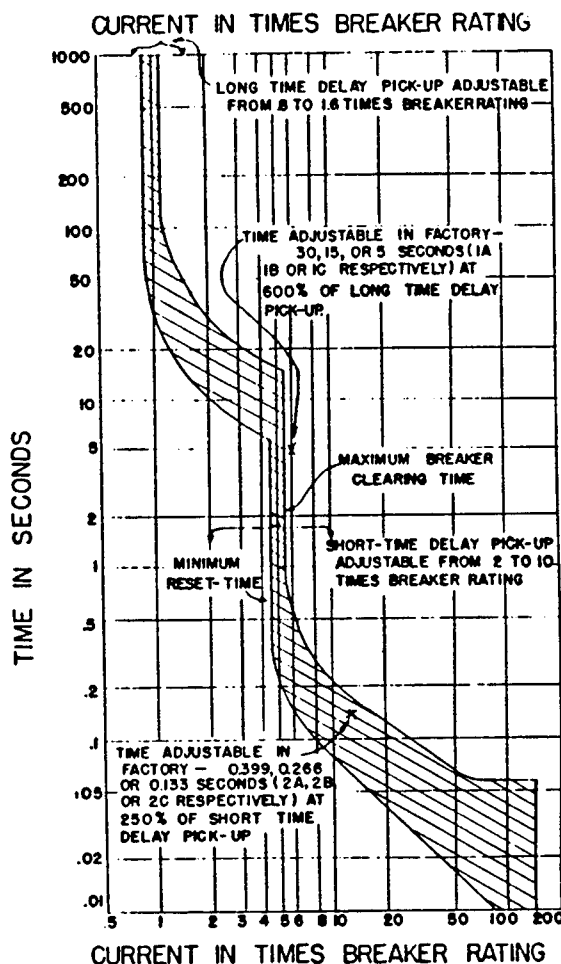

FIG. IIB  
LONG-TIME AND SHORT-TIME  
TRIPPING CHARACTERISTIC

Fig. 11 Typical Time-Current Characteristic

tripping. Lock adjusting nut.

Be extremely cautious not to have hands near moving parts of the breaker when making this adjustment.

#### REPLACEMENT

After removing the wiring for the potential coil the reverse current device can be removed and replaced by following the procedure outlined for replacing the series overcurrent device. For wiring, see Fig. 12.

### MISCELLANEOUS

#### SHUNT TRIPPING DEVICE

The shunt tripping device (refer to Fig. 13) is mounted on a bracket attached to the left side of the operating mechanism (looking from the front).

A remote switch or relay contacts are used to close the circuit of the device causing the arma-

ture (9) to engage the trip paddle (11), thereby tripping the breaker. The spring (2) is used to return the armature to the neutral position after the breaker trips.

To prevent overheating, the coil (7) is cut off by contacts of the auxiliary switch which are open when the breaker is open.

**GEH-1799 Type AK-1-50-1 Air Circuit Breaker**

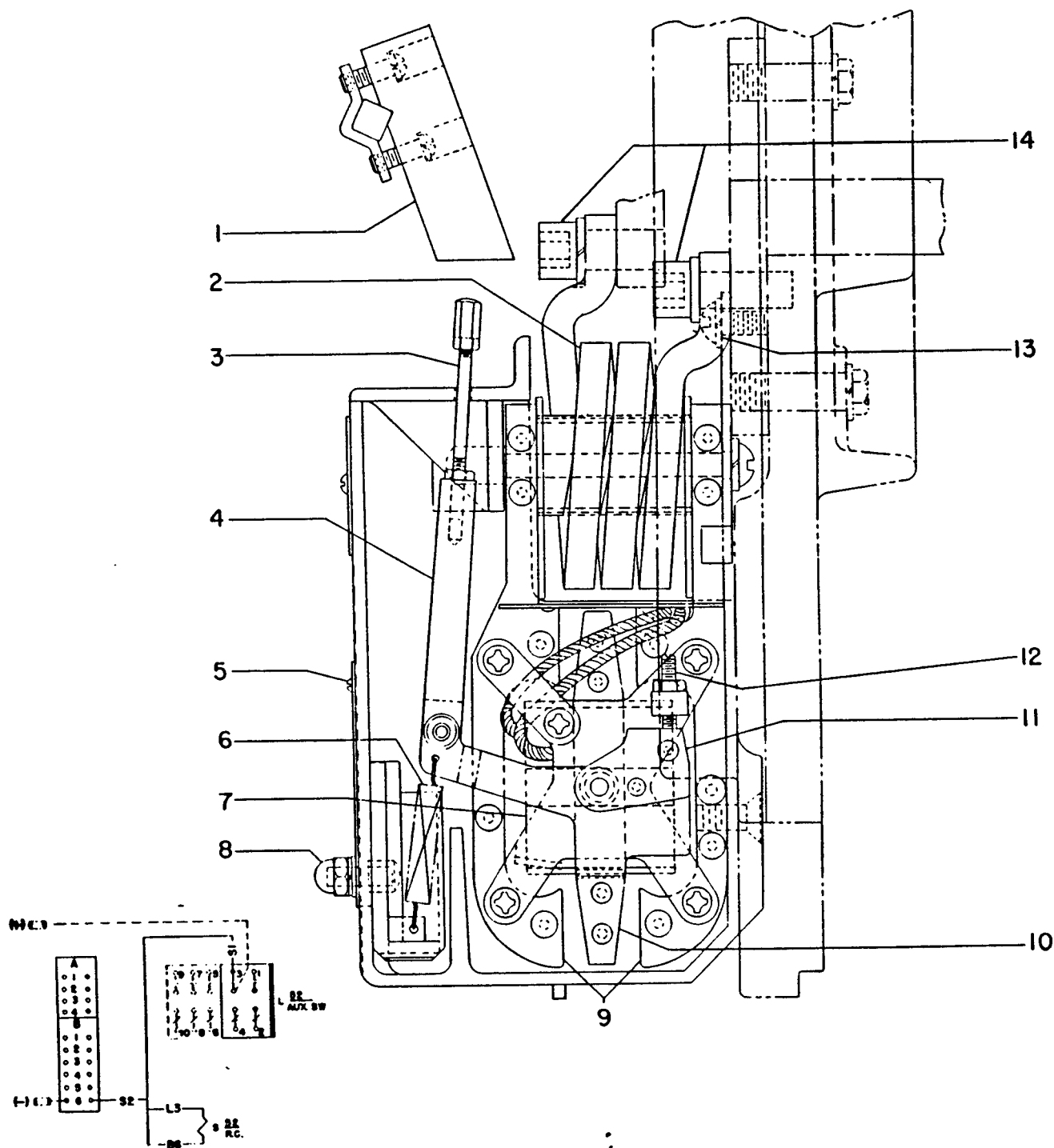

- |                          |                    |                    |
|--------------------------|--------------------|--------------------|
| 1. Trip Paddle           | 6. Spring          | 11. Counter Weight |
| 2. Series Coil           | 7. Potential Coil  | 12. Stop Screw     |
| 3. Trip Rod              | 8. Calibration Nut | 13. Mounting Screw |
| 4. Trip Crank            | 9. Pole Pieces     | 14. Screw          |
| 5. Setting Sealing Screw | 10. Armature       |                    |

**Fig. 12 Reverse Current Tripping Device**

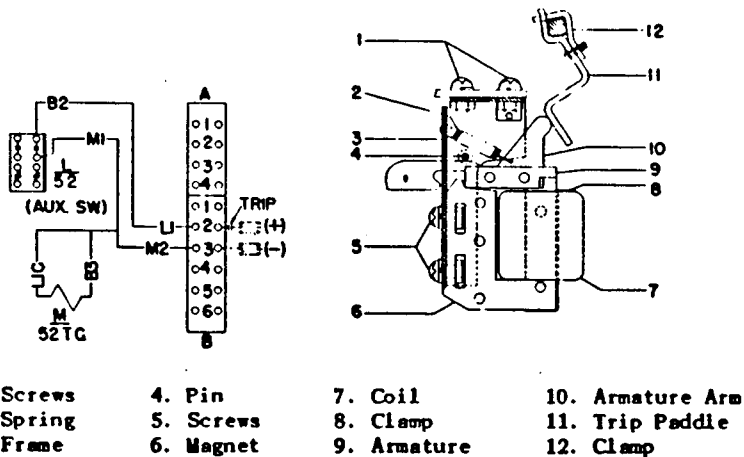

Fig. 13 Shunt Tripping Device

**ADJUSTMENTS**

From 1/32" to 1/16" overtravel of the armature is required when the breaker is tripped. If any adjustment is necessary to provide this amount of overtravel, the trip lever is bent in or out accordingly.

**REPLACEMENT - COIL (7)**

1. Disconnect leads to coil.
2. Remove magnet (6) and coil from frame (3).
3. Bend lower end of clamp (8) straight and remove.
4. Remove coil and install new coil in reverse order.

**BELL ALARM AND LOCKOUT DEVICE**

Refer to Fig. 14. When the breaker is tripped by an overload device, auxiliary shaft (9) rotates counter clockwise causing latch (8) to move off of latch arm (5). The breaker opens causing prop (3) to rotate clockwise allowing switch (2) to close. The switch then rotates latch arm (5) which, in turn, allows catch (11) to move downward thereby locking latch arm (5) in the rotated position. When in the rotated position the latch arm keeps the trip shaft and prop (3) in the trip-free position, thus keeping the breaker from being closed until the lockout mechanism is reset by means of reset button (1). When the switch is closed it sounds an alarm. If the breaker is tripped by any device other than an overload device, latch (8) keeps latch arm (5)

from rotating and therefore stops the bell alarm and lockout device mechanism from operating.

**ADJUSTMENTS**

1. With the breaker mechanism and lockout mechanism in the reset position adjusting screw (13) should be set so that auxiliary shaft (9) just touches the overload paddles on the trip shaft.
2. With the front frame assembled to the back frame the adjusting screws in the series overcurrent tripping devices should be adjusted so that there is approximately 1/16 inch to 3/32 inch clearance between screw and auxiliary shaft (9).

**DISCONNECTS**

The disconnects are attached to the circuit breaker studs at the rear of the breaker.

Each disconnect consists of eight contact fingers (5), four retainers (7), two spacers (4), two screws (1), one retaining ring (6), four washers (2) and four springs (3). The parts are assembled as shown in Fig. 16.

**ADJUSTMENTS, FIG. 16**

Tighten the nuts on screw (1) compressing springs (3) so that the spring length from retainer to washer does not exceed 1-1/32 inches. GREASE CONTACT FINGERS (5) WITH GREASE G.E. SPECIFICATION D50H28.

**RENEWAL PARTS**

When ordering renewal parts, address the nearest Sales Office of the General Electric Company, specifying the quantity required. The parts should be described and the complete nameplate data of the breaker should be given.

Renewal parts, which are furnished, may not be identical with the original parts since improvements are made from time to time. Parts which are furnished will be interchangeable.

GEH-1799 Type AK-1-50-1 Air Circuit Breaker

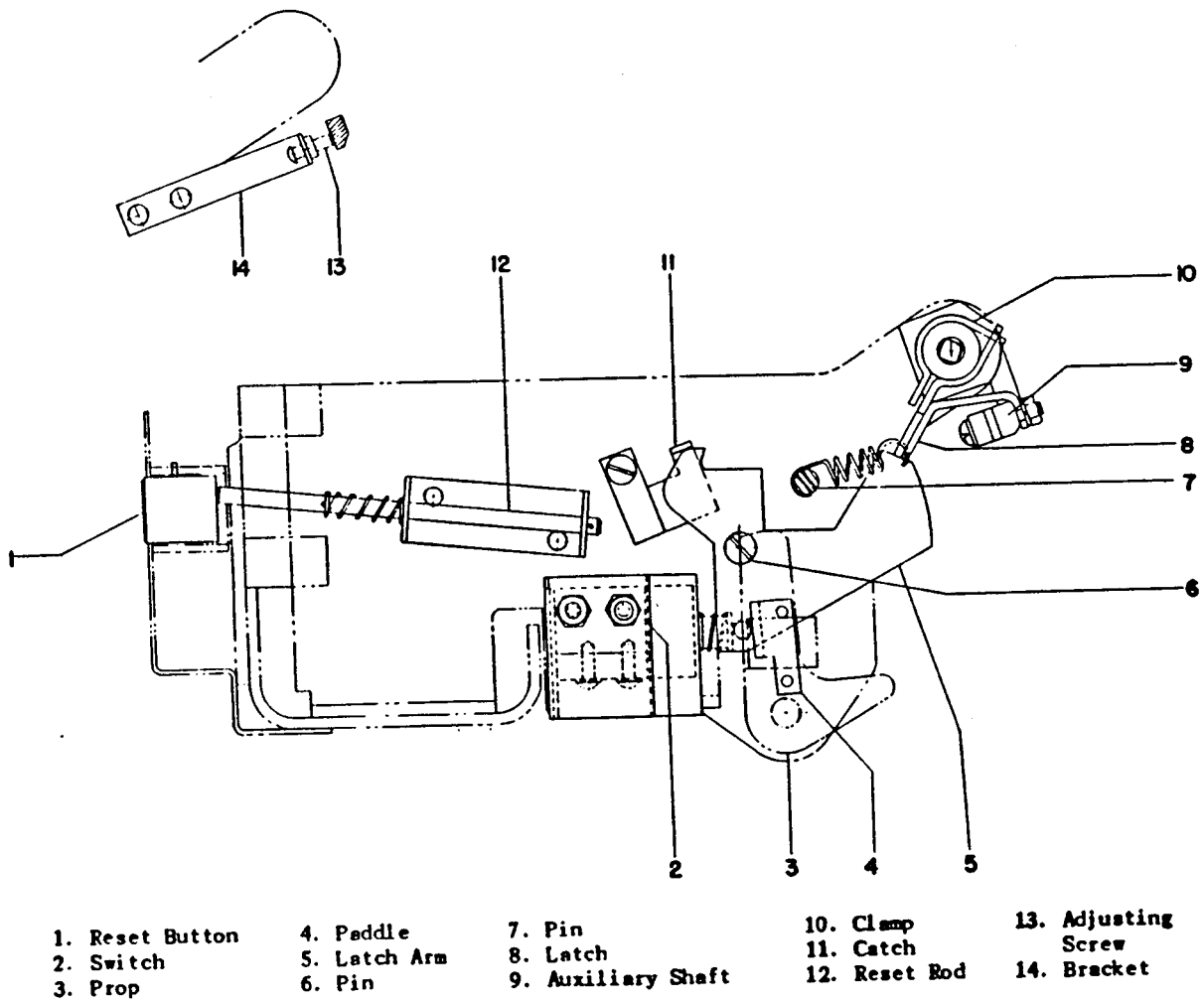

Fig. 14 Bell Alarm And Lockout Device

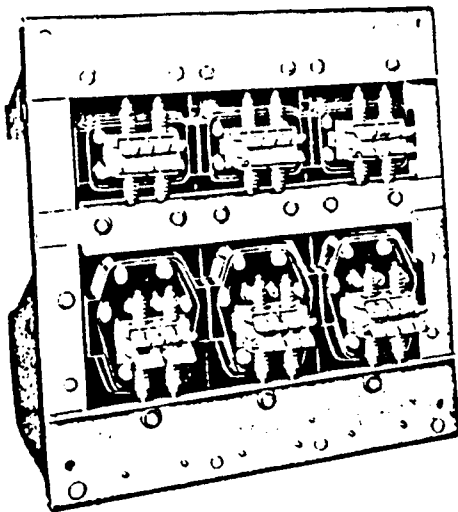
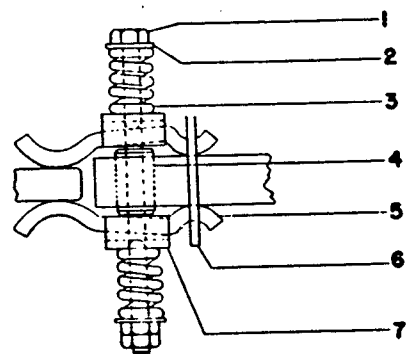

Fig. 15 Rear View Of Breaker, Showing Secondary Disconnects



1. Screw 3. Spring 5. Contact Finger 6. Retaining Ring  
2. Washer 4. Spacer 7. Retainer

Fig. 16 Secondary Disconnect



# RENEWAL PARTS

## TYPE AK-1-50-1 AND AK-1-50-2 POWER CIRCUIT BREAKER

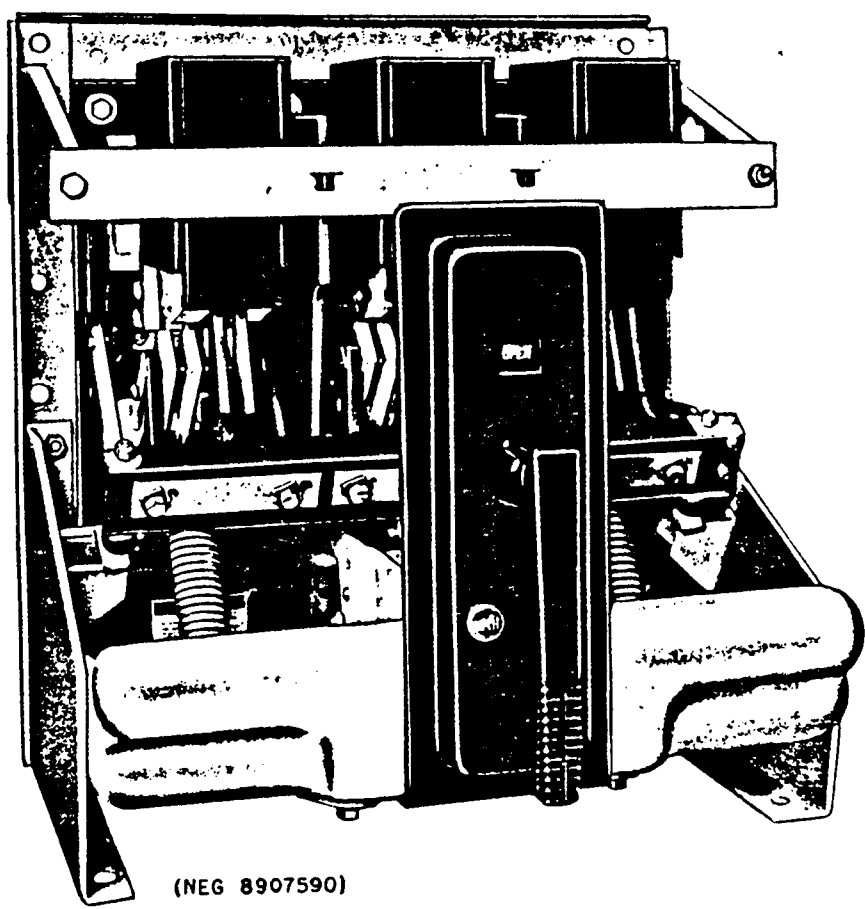

(NEG 8907590)

Fig. 1. Manual breaker, front view

### ORDERING INSTRUCTIONS

1. Always specify complete nameplate data of the support or breaker.
2. Specify the quantity, catalog number (if listed), reference number (if listed), description, and this bulletin number.
3. Standard hardware such as screws, bolts, nuts, washers, etc., is not listed in this bulletin. Such items should be purchased locally.
4. For prices, refer to the nearest office of the General Electric Company.

**POWER CIRCUIT BREAKER**

**COIL TABLE**

Cycles	Voltage	Shunt trip coil	Undervoltage device coil
25	115	6275081G26	6275081G5
25	208	6275081G29	6275081G3
25	230	6275081G29	6275081G3
25	380	6275081G7	6275081G17
25	460	6275081G7	6275081G17
25	575	6275081G5	6275081G21
50	115	6275081G24	6275081G4
50	208	6275081G26	6275081G5
50	230	6275081G26	6275081G5
50	380	6275081G4	6275081G3
50	460	6275081G4	6275081G3
50	575	6275081G29	6275081G6
60	115	6275081G25	6275081G26
60	208	6275081G26	6275081G27
60	230	6275081G26	6275081G7
60	380	6275081G27	6275081G31
60	460	6275081G27	6275081G31
60	575	6275081G7	6275081G10
D.C.	125	6275081G29	6275081G18
D.C.	250	6275081G30	6275081G19

Fig. No.	Ref. No.	Manual	Electrical	Cat. No.	Description
		No. Per Breaker			
2	1	2	2	6414763P1	Phase barrier
2	2	1	1	372A275G1	Lifting bracket, right
2	3	1	1	372A275G2	Lifting bracket, left
2	4	1	1	9921630P1	Arc quencher tie bar
2	5	1	1	267B101P2	Cross bar for drawout breaker
2	5	1	1	6414750P2	Cross bar for stationary breaker
2	6	2	2	6509914	Opening spring
3	7	-	1	†12HGA11J78	Relay, 25 cycles, 115 volts
3	7	-	1	†12HGA11J79	Relay, 25 cycles, 230 volts
3	7	-	1	†12HGA11J74	Relay, 50 cycles, 115 volts
3	7	-	1	†12HGA11J75	Relay, 50 cycles, 230 volts
3	7	-	1	†12HGA11J70	Relay, 60 cycles, 115 volts
3	7	-	1	†12HGA11J71	Relay, 60 cycles, 230 volts
3	7	-	1	†12HGA11J52	Relay, 125 volts, D.C.
3	7	-	1	†12HGA11J51	Relay, 250 volts, D.C.
		No. Per Pole†			
4	8	1	1	175L303G1	Arc quencher assembly, A.C.
4	8	1	1	175L303G5	Arc quencher assembly, D.C.
4	9	1	1	267B247P1	Plate, A.C.
4	9	1	1	267B161P1	Plate, D.C.
4	10	1	1	265B248P1	Side frame, right, A.C.
4	10	1	1	265B248P1	Side frame, right, D.C.
4	11	1	1	265B248P2	Side frame, left, A.C.
4	11	1	1	265B248P2	Side frame, left, D.C.
4	12	1	1	265B249P1	Baffle, A.C.
4	12	1	1	372A498G1	Baffle, D.C.
4	13	1	1	265B229P1	Cap, A.C.
4	13	1	1	6555518P2	Cap, D.C.
4	14	1	1	371A206P1	Block, A.C.
4	14	1	1	371A206P2	Block, D.C.
*	15	1	1	371A205P1	Magnet, A.C.
*	15	1	1	371A205P2	Magnet, D.C.
4	16	1	1	371A207P1	Compound support, A.C.
4	16	1	1	372A464P1	Compound support, D.C.
4	17	1	1	371A209P1	Steel back plate, A.C.
4	17	1	1	371A209P2	Steel back plate, D.C.
4	18	1	1	6414494P1	Pocket barrier, right, A.C.
4	18	1	1	6414494P1	Pocket barrier, right, D.C.
4	18	1	1	6414494P2	Pocket barrier, left, A.C.
4	18	1	1	6414494P2	Pocket barrier, left, D.C.

\* Not illustrated.

†Model Number

†To determine quantity required per breaker multiply by number of poles (2, 3 or 4)

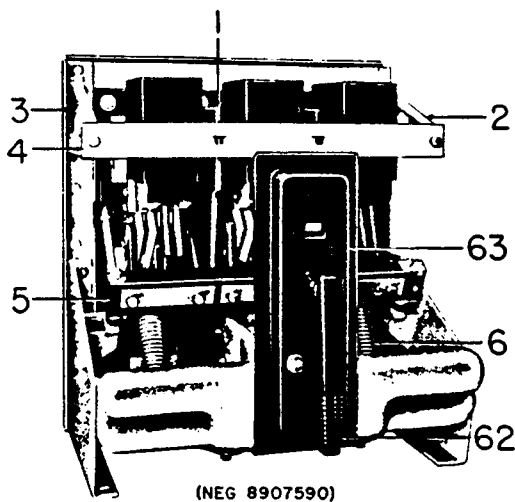

Fig. 2. Manual breaker, front view

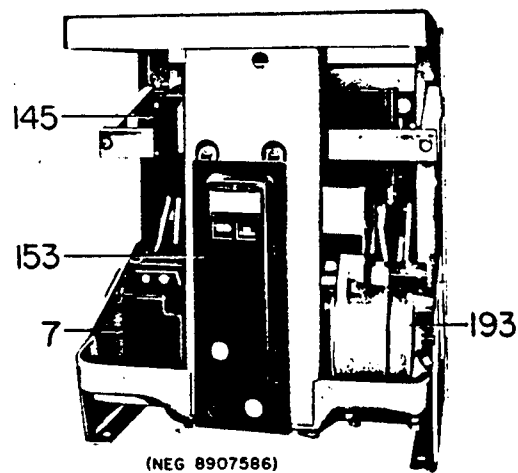

Fig. 3. Electrical breaker, front view

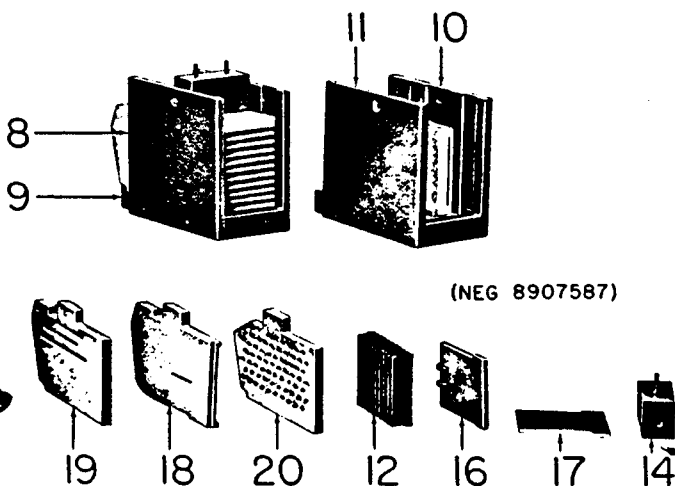

Fig. 4. Arc quencher

Fig. No.	Ref. No.	Manual	Electrical	Cat. No.	Description
		No. Per Pole†			
4	19	2	2	6414493P1	Side barrier, A.C.
4	19	2	2	6414493P1	Side barrier, D.C.
4	20	1	1	6414492P1	Inner barrier, A.C.
4	20	2	2	6414492P1	Inner barrier, D.C.

†To determine quantity required per breaker multiply by number of poles (2, 3 or 4)



# POWER CIRCUIT BREAKER

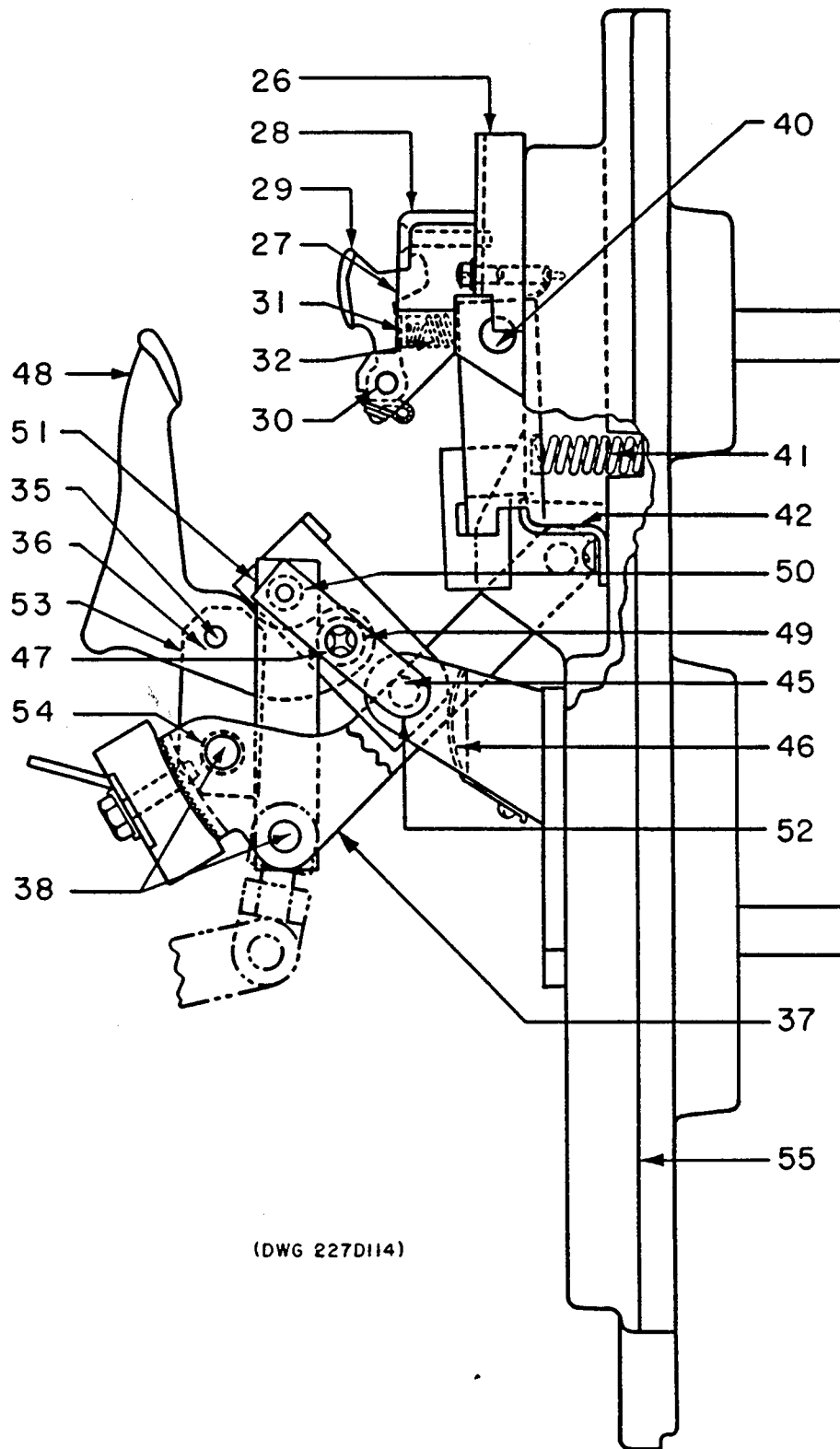

(DWG 227D114)

Fig. 5. Pole unit assembly

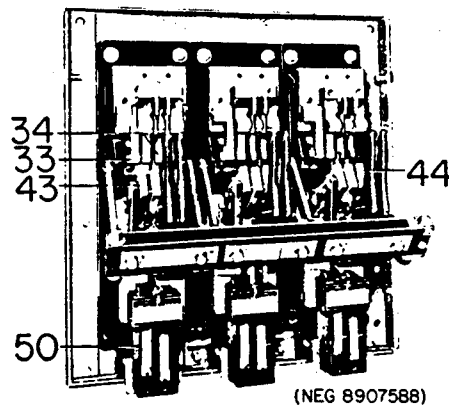
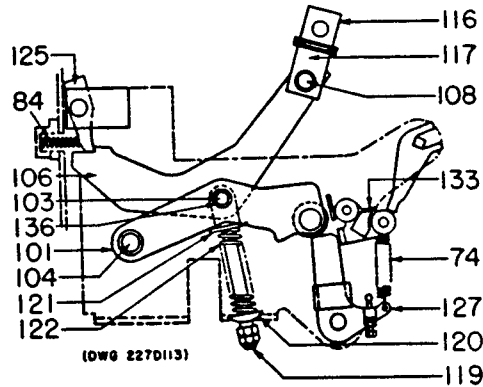
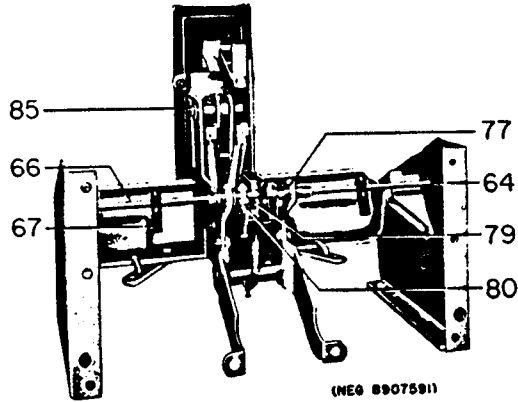

Fig. 6. Back frame assembly, front view

Fig. No.	Ref. No.	Manual	Electrical	Cat. No.	Description
		No. Per Pole†			
5	25	1	1	175L304G1	Pole unit assembly, A.C.
5	25	1	1	175L304G21	Pole unit assembly, D.C.
5	26	1	1	371A208P1	Spacer, A.C.
5	26	1	1	372A436P1	Spacer, D.C.
5	27	1	1	9921578P1	Spacer, A.C.
5	27	1	1	372A466P1	Spacer, D.C.
5	28	1	1	9921587P1	Contact stop, A.C.
5	28	1	1	372A465P1	Contact stop, D.C.
5	29	2	2	9921559G1	Stationary arcing contact, A.C.
5	29	3	3	9921559G1	Stationary arcing contact, D.C.
5	30	1	1	6404793P3	Pivot pin for stationary arcing contact, A.C.
5	30	1	1	6404793P2	Pivot pin for stationary arcing contact, D.C.
5	31	2	2	6447046P1	Spring guide for stationary arcing contact, A.C.
5	31	3	3	6447046P1	Spring guide for stationary arcing contact, D.C.
5	32	2	2	6509858P1	Spring for stationary arcing contact, A.C.
5	32	3	3	6509858P1	Spring for stationary arcing contact, D.C.
5	32	2	2	6509859P1	Spring for stationary arcing contact, A.C.
5	32	3	3	6509859P1	Spring for stationary arcing contact, D.C.
6	33	3	3	9921566P1	Stationary main contact -
6	34	1	1	175L304G40	Stationary intermediate contact -
5	35	1	1	6447153P3	Pin for movable arcing contact link, A.C.
5	35	1	1	6447153P1	Pin for movable arcing contact link, D.C.
5	36	2	2	394A133P9	Retainer for movable arcing contact link pin
5	37	1	1	175L304G37	Side link assembly, right
5	37	1	1	175L304G38	Side link assembly, left
5	38	2	2	6203981P1	Pin for side link
*	39	4	4	394A133P10	Retainer for side link pin
5	40	1	1	6447734P2	Pin for stationary main contact pivot
5	41	4	4	6509893P1	Spring for stationary main contact
5	42	1	1	9921576P1	Contact stop for stationary main contact
6	43	4	4	9921568G1	Movable main contact
6	44	1	1	9921568G2	Movable intermediate contact
5	45	1	1	6447734P1	Pin for movable main contact pivot
5	46	1	1	365A311P1	Spring for movable main contact
5	47	1	1	6447743P3	Pin for movable arcing contact pivot
5	48	2	2	9921572G1	Movable arcing contact, A.C.
5	48	3	3	9921572G1	Movable arcing contact, D.C.
5	49	3	3	6447773P1	Spacer for movable arcing contact, A.C.
5	49	2	2	6447773P2	Spacer for movable arcing contact, A.C.
5	50	1	1	6447736P1	Pin for movable main contact link
5	51	2	2	6404784P3	Link for movable main contact
5	52	2	2	6447743P1	Spring for movable main contact retainer
5	53	1	1	9921573P1	Link for movable arcing contact, A.C.
5	53	1	1	372A462P1	Link for movable arcing contact, D.C.
5	54	1	1	6447741P1	Tube for side link pin
5	55	1	1	6414314P2	Base for pole unit

\* Not illustrated. †To determine quantity required per breaker multiply by number of poles (2,3 or 4).

**POWER CIRCUIT BREAKER**



**Fig. 7. Front frame assembly for manual breaker, rear view**

**Fig. 8. Electrically operated mechanism**

Fig. No.	Ref. No.	No. Per Breaker		Cat. No.	Description
		Manual	Electrical		
9	60	1		175L302G2	Mechanism assembly, 2 pole breaker
9	60	1		175L302G1	Mechanism assembly, 3 pole breaker
8	61		1	175L315G5	Mechanism assembly, 2 pole breaker
8	61		1	175L315G1	Mechanism assembly, 3 pole breaker
2	62	1		6548046P2	Operating handle
2	63	1		9921604G1	Front escutcheon
7	64	2	2	377A871P2	End bearing for tripshaft
*	65	2	2	394A133P1	Retaining ring for tripshaft end bearings
7	66	2	2	265B234P1	Trip shaft
7	67	3	3	6447765P1	Overload trip paddle
*	68	3	3	6447766P1	Clamp for overload trip paddle
10	69		1	393A796P2	Crank bearing
*	70		1	394A137P1	Roll pin for crank bearing
10	71		1	393A796P1	End bearing for crankshaft
10	71		1	393A796P3	End bearing for crankshaft
9	72	1	1	6447744P1	Pin for reset latch
*	73	2	2	394A133P9	Retainer for reset latch pin
8	74	1	1	6403348	Spring for reset latch
10	75	1	1	265B234P2	Tripshaft
10	76	2	2	174V536P1	Tripshaft coupling
7	77	2	2	377A871P2	Bearings for tripshaft
9	78	1	1	6414764P1	Latch
7	79	1	1	6444916P1	Latch bolt
7	80	2	2	402P69B5	Latch washer
*	81	1	1	6403366P1	Spring for tripshaft return
*	82	2	2	394A133P11	Retainer for linkage pin
9	83	1		6509858P1	Spring for prop-closing cam
9	83	1		6509859P1	Spring for prop-closing cam
8	84		1	365A333P1	Spring for prop-closing cam
7	85	1		6447760P1	Bearing for crankshaft, right
7	85	1		393A796P4	Bearing for crankshaft, left
*	86	1		394A133P2	Retaining ring for crankshaft
*	87	8		6007608P2	Washers for crankshaft
9	88	1		175L302G37	Operating shaft assembly
9	89	1		175L302G38	Position indicator assembly
9	90	1		6172558P1	Spring for position indicator
10	95		1	6447032P1	Pin for spring charging arm
10	96		1	267B102G1	Crank
*	97		2	394A133P4	Retaining ring for spring charging arm pin
*	98		2	394A133P4	Retaining ring for spring support pin
10	99		1	6447010P1	Pin for closing spring support
10	100		1	273B569G1	Closing spring assembly
8	101		1	175L315G40	Link assembly

\* Not illustrated.

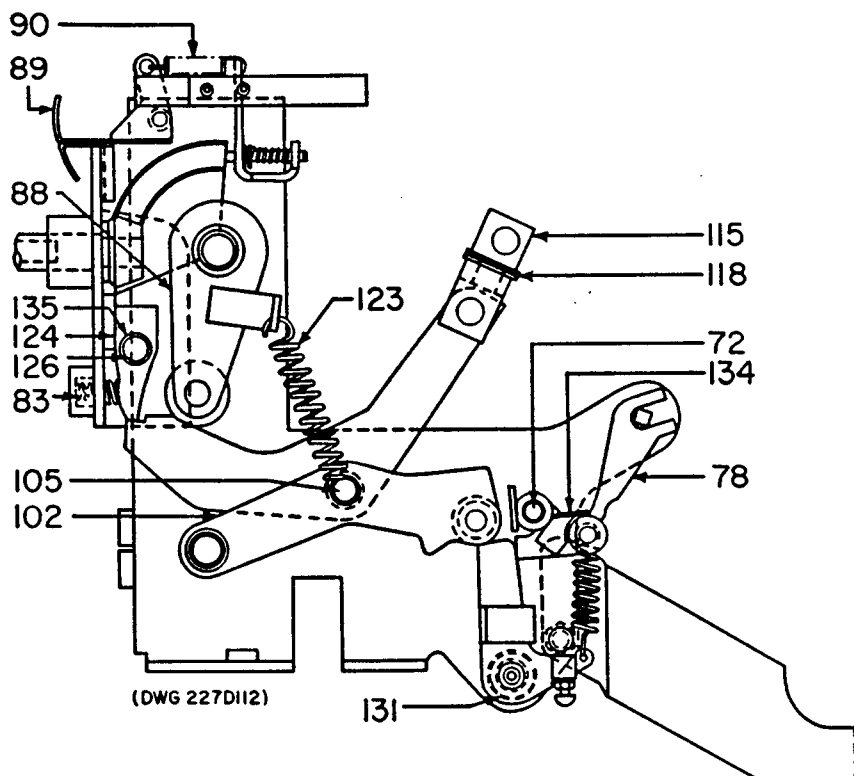

Fig. 9. Manually operated mechanism

Fig. No.	Ref. No.	No. Per Breaker		Cat. No.	Description
		Manual	Electrical		
9	102	1		175L302G40	Link assembly
8	103		1	6447091P1	Pin for closing cam
8	104	1	1	6447099P1	Pin for link
9	105	1		6447182P1	Pin for closing cam
8	106	1	1	6414743P1	Closing cam
*	107		2	175L315P24	Spacers for closing cam
*	107	2		175L302P17	Spacers for closing cam
8	108	1	1	6447352P1	Clevis pin
*	109	2	2	394A133P10	Retainer for clevis pin

\* Not illustrated.

## POWER CIRCUIT BREAKER

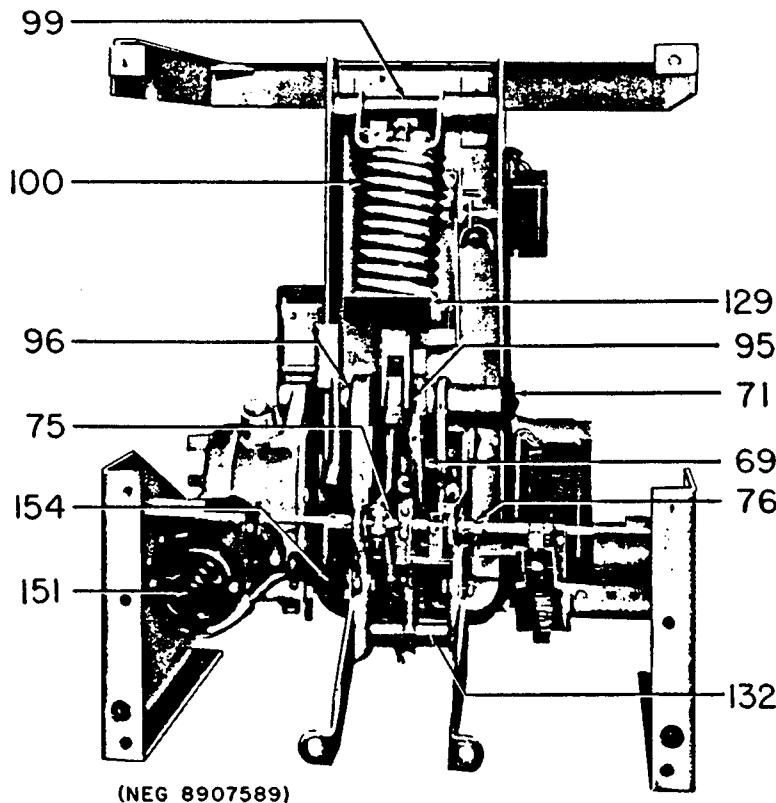
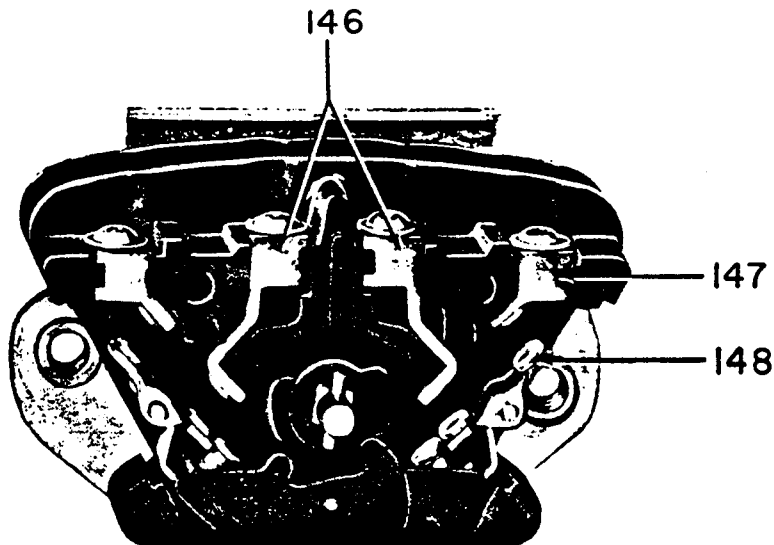

Fig. 10. Front frame assembly for electrical breaker,  
rear view

Fig. No.	Ref. No.	No. Per Breaker		Cat. No.	Description
		Manual	Electrical		
9	115	1		6447027P1	Coupling
8	116		1	6555414P2	Coupling
8	117	1	1	6447043P1	Clevis
9	118	2	2	9921652P4	Washer for clevis
9	118	2	2	9921652P5	Washer for clevis
8	119		1	6203914G1	Support assembly reset spring
8	120		1	6447353P1	Spring guide, lower
8	121		1	6447331P1	Spring guide, upper
8	122		1	6403393P1	Spring for reset mechanism
9	123	1		6203985P1	Spring for reset mechanism
9	124	1		371A273G1	Prop for closing cam
8	125		1	371A273G2	Prop for closing cam
9	126	1	1	174V531	Prop pin for closing cam
8	127	1	1	9921596G1	Prop for linkage
*	128	7	7	6007608P3	Washer for prop
10	129		1	6447151P1	Closing spring guard
*	130	2	2	394A133P9	Retainer for prop
9	131	2	2	377A871P2	Bearing for prop
10	132	1	1	6447748P1	Stop for prop
8	133		1	175L315G39	Reset latch assembly
9	134	1		175L302G39	Reset latch assembly
9	135	2	2	394A133P10	Retainer for closing cam pin
8	136	2	2	394A133P10	Retainer for closing cam pin

\* Not illustrated.



(NEG 8016716)

Fig. 11. Type SB-12 auxiliary switch, with back frame removed

Fig. No.	Ref. No.	No. Per Breaker		Cat. No.	Description
		Manual	Electrical		
3	145	1	1	6353562G2	Auxiliary switch, 2 stage
3	145	1	1	6353562G5	Auxiliary switch, 5 stage
11	146	†	†	6472067G1	Stationary contact, center
11	147	†	†	6472067G2	Stationary contact, outer
11	148	†	†	6402656G1	Movable contact
*	149	§		242C671G1	Auxiliary switch kit, 4 contact switch
*	149	§		242C671G2	Auxiliary switch kit, 10 contact switch
6	150	3	3	6319453A	Series overcurrent tripping device
6	150	3	3	6319457G1	Reverse current tripping device
10	151		1	5P66MA1 †	Motor, 115 volts, 25, 50, 60 cycles
10	151		1	5P66MA3 †	Motor, 208 volts, 50 cycles
10	151		1	5P66MA3 †	Motor, 230 volts, 25, 50, 60 cycles
10	151		1	5P66MA3 †	Motor, 380 volts, 50 cycles, used with transformer
10	151		1	5P66MA3 †	Motor, 460 volts, 25, 50, 60 cycles, used with transformer
10	151		1	5P66MA3 †	Motor, 575 volts, 25, 50, 60 cycles, used with transformer
10	151		1	5P66MA1 †	Motor, 125 volts D.C.
10	151		1	5P66MA3 †	Motor, 250 volts D.C.
*	152		1	61G27	Transformer, 380-230 volts, 50 cycles
*	152		1	76G327	Transformer, 460-230 volts, 25 cycles
*	152		1	61G27	Transformer, 460-230 volts, 50, 60 cycles
*	152		1	76G348	Transformer, 575-230 volts, 25 cycles
*	152		1	61G48	Transformer, 575-230 volts, 50, 60 cycles
3	153		1	9921602G1	Front escutcheon with provision for closing button
3	153		1	372A351G1	Front escutcheon without provision for closing button
10	154		1	9921661P1	Closing switch

† 4 furnished for 2 stage switch.  
10 furnished for 5 stage switch.

† Model Number

§ Manual breaker originally furnished without auxiliary switch.

\* Not illustrated.

POWER CIRCUIT BREAKER

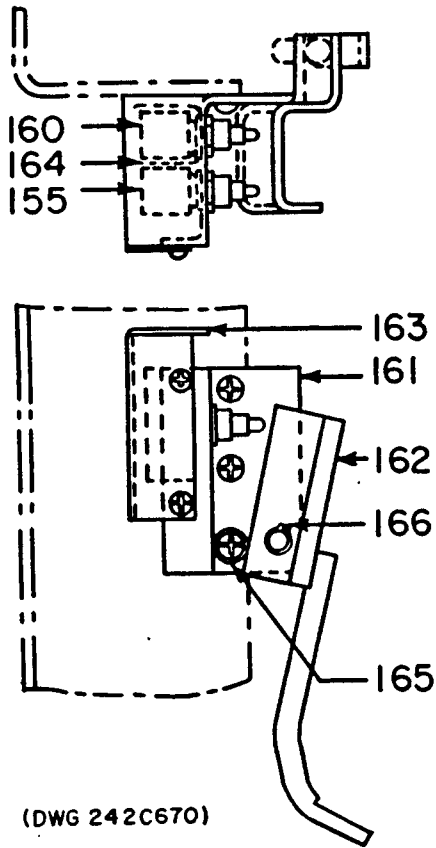

(DWG 242C670)

Fig. 12. Motor cut-off switch

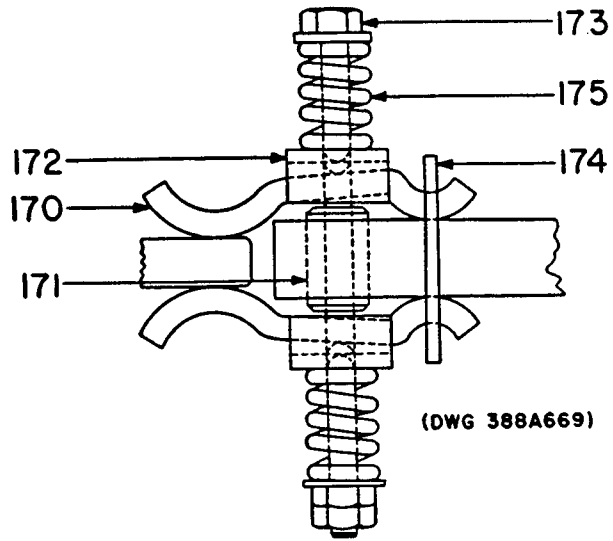

(DWG 388A669)

Fig. 13. Primary disconnect

Fig. No.	Ref. No.	No. Per Breaker		Cat. No.	Description
		Manual	Electrical		
12	155		1	9921661P1	Motor cut-off switch, "F"
12	160		1	9921661P2	Motor cut-off switch, "G"
12	161		1	371A233G1	Cut-off switch mounting bracket
12	162		1	371A234G1	Cut-off switch lever bracket
12	163		1	371A235P1	Cut-off switch cover
12	164		1	174V521P1	Cut-off switch insulation
12	165		1	6176109P17	Spacer for cut-off switch
12	166		1	394A133P9	Retaining ring for cut-off switch
*	167	1	1	6293908G32	Terminal board, 4 point
*	168	1	1	6293908G33	Terminal board, 6 point
13	169	3	3	175L305G1	Primary disconnect assembly
13	170	48	48	6403870P1	Contact fingers
13	171	12	12	6447772P1	Spacer
13	172	24	24	9921617P1	Retainer
13	173	12	12	175L305P24	Screw (1/4-20 x 4 3/4 in. steel)
13	174	6	6	9921616P1	Retaining ring
13	175	24	24	6403319	Spring
14	180	1	1	6319456G1	Shunt trip device, less coil
14	181	1	1	Δ	Shunt trip coil
14	182	1	1	6172583	Shunt trip spring

Δ See Coil Table.

\* Not illustrated.

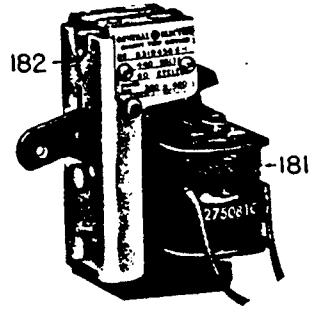

(NEG 8016671)

Fig. 14. Shunt tripping device

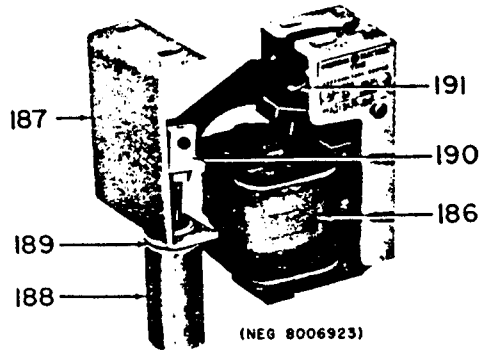

(NEG 8006923)

Fig. 15. Time-delay undervoltage tripping device

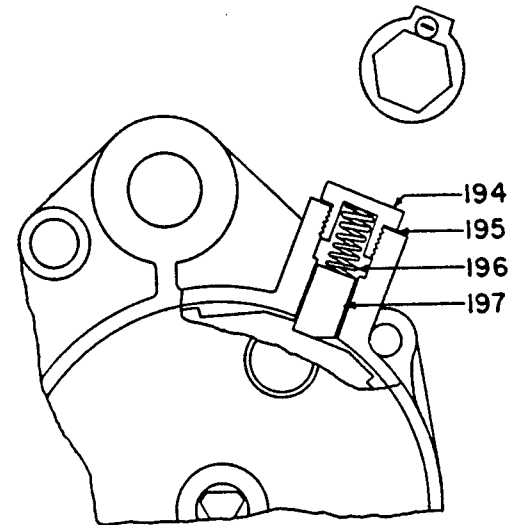

(DWG 242C669)

Fig. 16. Section of gear box

Fig. No.	Ref. No.	No. Per Breaker		Cat. No.	Description
		Manual	Electrical		
15	185	1	1	6319456G7	Undervoltage device, instantaneous, A.C.
15	185	1	1	6319456G9	Undervoltage device, instantaneous, D.C.
15	185	1	1	6319456G8	Undervoltage device, time delay, A.C.
15	185	1	1	6319456G10	Undervoltage device, time delay, D.C.
15	186	1	1	Δ	Undervoltage device coil
15	187	1	1	6319456G40	Cylinder support and guide
15	188	1	1	6403126P1	Cylinder
15	189	1	1	6444315P1	Gasket
15	190	1	1	6403128G1	Plunger and link
15	191	1	1	6172594	Spring
*	192	1	1	393A991P2	Silicone oil #9981LT40NV, 1/4 oz., with bottle
3	193		1	175L316G1	Gear box assembly
16	194		1	6447398P1	Plug
16	195		1	393A992P1	"O" ring for plug
16	196		1	372A283P1	Ratchet pin
16	197		1	6509871P1	Spring for ratchet pin
*	198		1	6447101P1	Motor gasket
*	199		1	393A991P1	Lubricant for gear box, 4 oz.

Δ See Coil Table.  
 \* Not illustrated.